



AS302SG
OPERATIONS MANUAL

PART NUMBER: SG07230003
REV: D

Component Technology
A DIVISION OF
 **Certified Power Inc.**

Factory Operations Manual

Electronic Ground Speed Spreader Control

with pre-wet liquid control



For assistance with installation, operation, programming, upgrades, repair or spare parts, please contact your dealer or the manufacturer.

Provide the following information with your request.

- Model number and the serial number, located on the rear of the unit.
- Your agency or company name and location.
- Contact information for a person to receive our response.
- Name of the dealer where the unit was purchased.
- A detailed description of your problem or request.

AS3 Operations and Installation Manual

Description

The AS3 spreader controller provides both manual and automatic spreader operation. In automatic spreader mode the AS3 accurately maintains a constant pounds per mile output as the vehicle's speed varies. The AS3 will control three electro-hydraulic proportional flow control valves; conveyor (auger), spinner and a pre-wet liquid valve. The AS3's proportional valve control is fully adjustable with both minimum and maximum drive current (or voltage) settings and the PWM frequency. The AS3 will accommodate most any electro-proportional valve.

The AS3's front panel incorporates two rotary selector switches for the operator's **Feed Rate** and **Lane Width** adjustments. The Feed and Lane settings are reported to the operator from a digital display located directly above each rotary switch. Both rotary switches are detented with bi-directional with endless rotation and an integral pushbutton. This combination switch allows the operator to change the Feed Rate and Lane Width with fast digital precision. For Pass and Blast simply push each pushbutton. Special selections are accomplished by push-n-turn. The front panel is backlit and organized using color features and a three character alpha-numeric display.

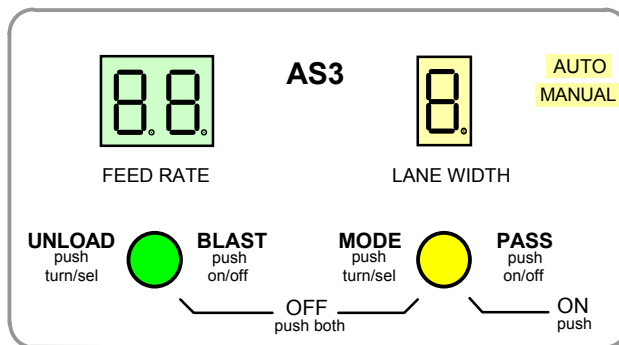

AS3 Spreader Features

- Nine programmable levels of Feed Rate for conveyor (auger) control with true lbs/mile calibration
- Nine programmable levels of Lane Width for spinner control, with zero MPH shut on/off
- Select number of Lanes Widths, 2 to 9 lanes
- Auto or Manual operation, six different configurations, including manual lock out
- Blast with adjustable off-delay timer, push on/off control, remote switch option
- Pass feature with instant push on/off control, remote switch option
- Unload material (full conveyor output) with vehicle speeds up to 5 mph
- Four granular products, operator selectable
- Optional liquid pre-wet output, turns on and off with the conveyor valve
- Internal audible beeper, verifies certain functions for the operator
- MPH ratio change for two speed rear ends
- Optional remote power up switch

Electrical Specification

- Operating voltage: 11 - 15 vdc, standard 12 volt mobile vehicle electrical system, (neg) ground
- Outputs: (3) current controlled PWM valve drivers, 2.5 amps each, overload sensing/protected
- Inputs: (4) mph sensor types, AC (vrn), DC sink, DC source and Coupled types
- (2) auxiliary inputs for current sinking devices, ie. remote switches
- Front panel: Back lighted, non-glare, detented rotary switches, alpha-numeric display
- Wiring interface: CPC, 9 pin *Motiv* standard, drop in replacement for DS2's, AS2's, MS2's
- Enclosure: steel with universal bracket for under, over and back panel mounting
- Calibration: all calibrations are set via the front panel, no tools required, pass code protected.

Operator Controls Power, Spinner, Conveyor, Displays

The operator has two control knobs located on the front panel. See sketch below, each knob responds to cw and ccw rotation and each knob is also a pushbutton. The combination of push and turn creates three different actions for each knob; **turn**, **push-n-release**, **push-n-turn**.

The following table is an overview of the six spreader functions as assigned to the multiple knob actions.

- | | | |
|-------------------------|----------------|---|
| • <u>Feed Rate</u> | Turn | ... selects one of nine Rate settings, power off |
| • <u>Blast</u> | Push-n-release | ... conveyor output = 100% w/ an off-delay timer |
| • <u>Unload</u> | push-n-turn | ... conveyor output = 100% to empty the hopper |
| • <u>Lane Width</u> | Turn | ... selects one of nine Lane settings, power on-off |
| • <u>Pass</u> | Push-n-release | ... instant off for the conveyor and spinner |
| • <u>Product select</u> | Push-n-turn | ... select 1 of 4 products |

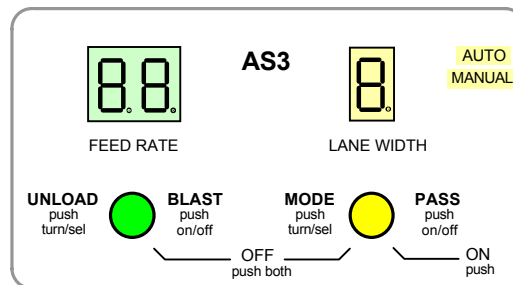

Power on/off

- To turn the AS3 **ON** **Push just the Lane Width knob and release**
... you will hear an audible chirp, confirming the power up
- To turn the AS3 **OFF** **Push both the Feed Rate and Lane Width knobs**
... hold for 1 second and release, entire front panel goes blank

Lane Width Control with Pass, Auto/Manual and Product select

- After powering up, the AS3 pre-sets the spinner output = 0, factory default
 - to setup the number of active lanes, see menu 31
 - to set the start up Lane Width, see menu 41
 - to set the start up spreader auto/manual mode, see menu 39
 - to set the overall spinner operation, see menu 04
- To change the **Lane Width** simply turn the Lane Width knob cw to increase and ccw decrease the output. The display just above the Lane Width knob will show your selection; **0 – 9**.
0=Off, 1 is the lowest and 9 is the highest.
- Push and release the Lane Width knob to enable **Pass**. Push and release again to disable Pass. The display will show **PA S**. Note; Blast will override Pass, see Feed Rate knob.
- Push-**hold in**-turn the Lane Width knob two detents cw to select **Manual** operation or two detents ccw to select **Automatic** operation. The Auto / Manual LED status indicator provides confirmation.)
- Push-**hold in**-turn the Lane Width knob cw to select the **Product number**. Note, the vehicle must be stopped to change the Product. As the Lane knob is first pushed the AS3 will move thru the Pass selection and then as you rotate the knob the AS3 will move thru the auto/man selection and as you finally turn the knob far enough (approx. six detents) the display will show **Pr # (1- 4)**. Once the desired product number is selected release the knob and the AS3 will save your selection and return to your last operator settings. Note, as you are scrolling thru the four choices the current product selection is identified by a decimal point that follows the product number.

Displays

The AS3 uses a simple three character LED display to present a wide variety information to the operator. Through out the AS3 manual you will see notations to point out the individual displays and codes, ex. **bL** means Blast and **PA S** is for Pass. The following chart shows the common operator displays. More detailed displays are revealed later in the programming section of this manual and are not generally relevant for the operator.

In addition to the three alpha-numeric characters there are two status indicators which show thru from the backside. One is for **Auto** and another is for **Manual** spreader operation. Plus an audible beeper.

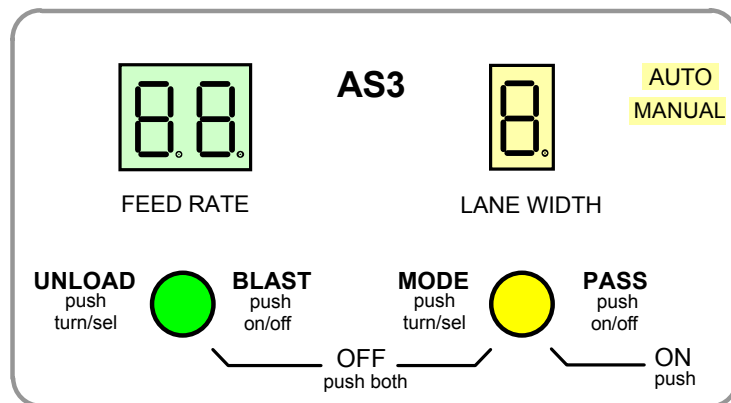

Common Operator Displays

- 8.8. 8. first display at power up, shows all character segments, indicates a power reset occurred
- 0 0 initial startup; Feed Rate (conveyor=0) and Lane Width (spinner=0)
- 2 4 Feed Rate = 2 and Lane Width = 4 (a typical run display)
- bL 3 Blast = on, Lane Width = 3
- PA S Pass = active, both Feed Rate and Lane Width outputs are off
- UL 0 Unload is active, spinner is off
- Pr 2. Product number two is selected
- Or 3 (Or is blinking) conveyor has overrun its capacity, Lane Width = 3
- PS I Conveyor stall, inputs 1 or 2 active due to a high PSI condition
(aka 07E error displays PSi) (beep) (see menus 11-1 and 12-1 for input setup)

In the upper right corner of the AS3 front panel are two backlite words, (auto and manual). These two indicators inform the operator it the spreading mode.

Auto (blinking) means the vehicle is not moving.

Auto (on steady) means the vehicle is moving, > 1 mph

Manual means the spreader is in manual operator mode

AS3 Error codes (the E designates an error)

- 01 E conveyor shorted valve coil, circuit is < 2 ohm
- 02 E conveyor open, valve coil, circuit is > 40 ohm
- 03 E spinner shorted, valve coil, circuit is < 2 ohm
- 04 E spinner open, valve coil, circuit is > 40 ohm
- 05 E valve supply internal fuse blown (this fuse is not field serviceable)
- 06 E vehicle battery supply < 10.5 volts DC
- 07 E high pressure stall switch, (beeps) aka **PS I** (see above)
- 08 E liquid shorted valve coil, circuit is < 2 ohm
- 09 E liquid open, valve coil, circuit is > 40 ohm

Installation with initial power up and check out

Always install the AS3 inside the vehicle cab. The 3-piece bracket is designed to offer the installer a selection of mounting positions. Above, below or behind a panel. (see mounting drawing) Ensure the AS3 is mounted in a position that gives the operator easy and clear access to the control knobs. Make a secure mount to avoid vibration. Route the cable harness to the required locations and make the connections as per the wiring diagram (see wiring drawing).

The process of setting up and calibrating the AS3 spreader control is made easier by proceeding through the following steps in sequence. The following steps are an operational check list for verifying the overall spreader control. Do not proceed on with the programmable calibration settings until the following operational items check out correctly.

1. **Hydraulic** components are to be fully plumbed and ready to run.
2. **Cable harness** installed with all devices and terminations completed.
(mph signal wire can remain unconnected until later in the test)
3. AS3 controller is **mounted**, cable connected and 12 volt power is ready to go.
(note; the AS3 is a negative grounded device)
4. To **power up** the AS3 simply press the Lane Width knob in and then release when the digital display comes on, you will also hear a short audible chirp confirming the power up is complete.
5. Switch the AS3 to manual mode to **check out the conveyor and spinner** operation. First, push in Lane Width knob and hold it in. Next, rotate the knob clockwise 2 detents, look for auto lamp to go off and the manual lamp to come on, release knob. The AS3 will now directly output manual drive signals to the conveyor and spinner valves. (go to step 6)
6. From manual mode you are to verify the basic hydraulic operation. Simply rotate the Feed Rate knob to change the speed of the conveyor or rotate the Lane Width knob to change the speed of the spinner. Operate both knobs throughout all of the settings 0, 1, 2, 3, ... 9 and verify proper hydraulic operation. Check for proper rotation, leaks, etc. Note; the min and max speeds may not be accurate at this point. Fine tuning individual adjustments is made later in the program setup section.
7. If liquid is used verify liquid output, (liquid output is active anytime the conveyor is active)
8. **MPH test.** First you will need to determine the type of MPH sensor. Most trucks manufactured today use electronic MPH signals generated from the transmission or ECU (engine control unit). The AS3 includes a program step where the installer must select the MPH signal type. (see menu 05)

The AS3 offers an input circuit for the four types of sensors;

- AC zero crossing signal generator with a 300 mv ac peak-peak threshold
- DC sink current sinking sensor, open collector NPN typ. V in low = 1vdc max, V in high = 6vdc min
- DC source current sourcing sensor, open emitter PNP typ. V in low = 1vdc max, V in high = 6vdc min
- Coupled edge sensing, series capacitive coupled, 1uf

General tips: Vehicles with ECU the mph signals are typically DC sinking type. For trucks where the installer is going to tap into the transmission tail shaft sensor, use the AC type. Some newer small body trucks use the DC sourcing sensors. The option to use Coupled is usually done when the other types won't work.

With the mph signal correctly wired, power up the AS3, in auto mode, auto lamp blinks when there is **NO** mph signal being generated (normal). Jack up the rear end of the vehicle, be safe and use wheel blocks. Put the transmission in gear and let the rear wheels rotate ~ 5mph. If the auto lamp goes from blinking to on-steady you have a good mph signal. If the auto lamp remains blinking you will need to change the mph sensor type. (see menu 05)

9. If the spreader valves and motor speeds operate and the AS3 can detect a MPH signal then you are ready to proceed with the detailed setup and programming tasks.

How to access the program mode

Start with the unit powered off and simultaneously press-n-hold *both* the Feed Rate and Lane Width knobs (pushbuttons). Hold both knobs in for about 3 seconds, observe the unit power up and display stops on **SH O** (this is short hand for "show" or view only mode), release both knobs. Next, you must enter the pass code, press-n-hold just the Feed Rate knob and then turn the Lane Width knob until the correct three digit pass code appears on the display. Release the Feed Rate knob, the display now shows **Pr g** (this is short hand for "program mode"), If the pass code entered is incorrect the display will return to showing **SH O**, (view only mode). The correct pass code for the AS3 is located on the last page of this manual.

To exit the program mode, from any menu # you can simply press both pushbuttons and hold them for ~3 seconds. The display will show **SH O** and then a moment later the display = **8.8. 8**. You can now release both pushbuttons, you're be back in normal run mode.

How to make changes to the internal memory settings

Once you're in program mode re-use the following two steps to make changes to any of the internal settings. Note, some menu items are view only.

- A. **Select a menu #** you want to edit from the program list. First, press-n-hold the Lane Width knob while turning the Feed Rate knob until the desired menu number is displayed, **xx P**. (xx = program menu number ranging from 01-99, this list may change as new features are added).
- B. To **change a setting** press-n-hold the Feed Rate knob and then turn the Lane Width knob until the desired setting is displayed. The newly changed setting is automatically and immediately saved into the non-volatile memory (no special battery backup is required).

Program List

The AS3 uses a simple list of menu numbers to assign each adjustment, mode or feature selection. The program list has been organized into logical groupings and presented in a sequence that aids the installer. At the head of each section there is a brief description of the installers task. Within the body of the text are references to other areas the installer should consider. Through out you will see a notation like; (**xx**), This highlighted value denotes the factory setting for that menu item. The factory settings were selected to give the installer a basic operational system. Changes to the factory settings are expected since every vehicle, its hydraulic components and individual spreading policies are different.

Menu #	Name	Description
01	<u>Pass code</u>	Entering the correct pass code will display Pr g allowing the installer to make changes to the program settings. The incorrect pass code will display SH O and allow the user a <u>view only</u> mode.
02	<u>Program ID</u>	3 digit version (checksum), see version log on the last page of this manual for the history of dates, codes and changes that have been made.
50	<u>Input hardware test</u>	verify inputs Displays status for Auxiliary inputs #1, #2 and MPH 0 = input low, 1 = input high, 0-1-0 = signal pulses left digit = aux input 1, pin 5 center digit = aux input 2, pin 1 right digit = MPH, pin 8
51	<u>Serial number</u>	factory set view only, 3 digit number, used for warranty

Operational modes, timers and options

Menu #	Name	Description	Note (xx) denotes factory settings
03	<u>Conveyor mode</u>	1 = Manual conveyor operation only, no mph modulation, conveyor simply follows the operators knob selections, blocks auto spread mode 2 = Auto conveyor, w/ mph modulation, spreader mode auto or manual 3 = Auto conveyor only, manual spread mode locked out, unload allowed	
04	<u>Spinner mode</u>	0 = Locked out, no spinner operation, lane width only displays 0 (Off) 1 = Manual, spinner simply follows the operators knob selections 2 = Spinner automatically starts-stops w/ mph, when in auto spread mode	
05	<u>MPH sensor type</u>	Define the type of ground speed sensor, ref. speed input, pin 8 Ac = ac sensor, VRM Acd = ac sensor w/ differential coupling dc = dc current sinking type sensors dcn = dc current sourcing type sensors	
06	<u>Set Counts/Mile</u>	Enter <u>cts/mile</u> [Cts/mile range is 1000 – 200,000] factory 26,700 (note display X 1000 = cts/mile). Also, use menu 07 for MPH calibration.	
07	<u>MPH view/calib</u>	View MPH, For calibration by matching, press-n-hold Rate knob, turn Lane knob (slowly) until AS3 display matches the vehicles speedometer, best at ~20 mph. Adjust slowly to allow MPH filter time to respond.	
08	<u>2 speed ratio</u>	Enter the ratio of the 2-speed rearend, range (0.2 to 5.0) factory 1.00 note; The AS3 creates a calculated MPH to be used for Feed Rate control. Using a 2 speed rearend requires a switch or relay be used to pull pin 5 to ground. First calibrate the MPH with pin 5 open and then when pin 5 is grounded by the switch the AS3 will Calc. MPH = calib MPH / ratio	
09	<u>Blast timer</u>	Enter off-delay time range (0 - 30 seconds), (0 seconds sets timer = off) factory 5	
10	<u>Blast type</u>	tr i = blast outputs maximum valve trim rt E = blast outputs Feed Rate programmed in for position 9	
11	<u>Aux. Input 1</u>	(ref. pin 5) Aux. Input 1 is active when pin 5 is pulled to ground. 0 = input 1 is not used 1 = remote psi switch for sensing conveyor stall 2 = remote switch for Pass 3 = remote switch for Blast 4 = remote switch for two speed rearend 5 = remote power signal	
12	<u>Aux. Input 2</u>	(ref. pin 1) Aux. Input 2 is active when pin 1 is pulled to ground. 0 = input 2 is not used 1 = remote psi switch for sensing conveyor stall 2 = remote switch for Pass 3 = remote switch for Blast 4 = remote switch for two speed rear end	

Valve drive setup PWM freq., current/voltage control, min and max trim

The valve drive circuits are factory calibrated and preset for current mode operation. It's recommended that you use current control which regulates the PWM to hold the current constant thus compensating for changes in battery voltage and valve coil resistance due to thermal effects. However, if you're experience difficulties with a particular valve coil operating in current mode you can change to voltage control mode. In either mode, the AS3 always displays the valve drive settings as a percent number of full scale, (range .1 – 99.9%)

Menu #	Name	Description
13	<u>PWM freq.</u>	enter PWM frequency, range (30 to 300 hertz) factory = 120
14	<u>Conveyor drive mode</u>	Cu r sets conveyor drive to current control factory = Cu r OL t sets conveyor drive to voltage control
15	<u>Spinner drive mode</u>	Cu r sets spinner drive to current control factory = Cu r OL t sets spinner drive to voltage control
16	<u>Conveyor min trim</u> *	enter min valve drive, observe conveyor shaft for min desired speed. set for a slow smooth creep speed, factory 25%
17	<u>Conveyor max trim</u> *	enter max valve drive, observe conveyor shaft for max desired speed. set for the max shaft speed without overdriving the valve, factory 75%
18	<u>Spinner min trim</u> *	enter min valve drive, observe spinner shaft for min desired speed. sets the spinner speed for Lane Width no. 1, factory 25%
19	<u>Spinner max trim</u> *	enter min valve drive, observe spinner shaft for min desired speed. sets spinner speed for highest assigned lane, factory 50% (The highest lane number is factory set at 9, see menu 31)
(*)	<u>To adjust a valve trim</u> ;	First select the correct menu # (16-19), next press-n-hold the Feed knob and adjust the Lane knob for the desired shaft speed output. Repeat these steps for each of the four valve trims.

Conveyor trim considerations: The conveyor min is the easiest setting to make, simply adjust the valve min trim for a slow smooth creep speed as observed at the conveyor shaft. The conveyor max is a little more difficult, the installer needs to set the valve max for the greatest shaft speed without overdriving the valve. The best approach is to adjust the max trim from a low setting proceeding slowly to higher settings until the max conveyor RPM is just achieved. Using a handheld RPM gauge on the conveyor shaft will create a more accurate result. Raising the max trim beyond the peak RPM will distort the conveyor calibration. (see menu 20)

Spinner trim considerations: The spinner min is always associated with Lane Width 1 and the spinner max is associated with the highest Lane Width selected. (see menu 31). Also important, whenever making spinner adjustments with an empty spinner (no granular material) it will rotate without a load and tend to spin too fast. The AS3 has a feature where the installer can have granular material dump from the conveyor while making the individual spinner adjustments. (see menu 30)

(Special note) There is a built in current meter (amp-meter) within the AS3 that can be useful for troubleshooting. When setting any of the valve trims, menus 16-19, before pressing the Feed PB simply rotate the Feed Rate knob cw a few clicks. The display now shows a number corresponding to milliamps. The displayed current is only updated every .75 sec., be patient and adjust the valve trim slowly. To return to viewing the valve drive as a percentage turn the Feed knob ccw a few clicks before pressing the Feed PB.

Lane Width active conveyor, set number of lanes, spinner speeds

Lane Width Menus 30 - 38 allow the installer to set the spinner speed for each switch position on the Lane Width knob. You may also define the number of lanes available to the operator and have the conveyor run during spinner adjustments for a more accurate results.

30 Conveyor active This is feature allows the installer to run the conveyor while setting the spinner speeds. This achieves a more accurate result since the granular material effects the spinner speed. A visual verification of the spinner distance (throw) also creates a better result. The number you enter is a percentage (0 – 99%) to directly control the conveyor speed This feature resets to zero (turns off) each time you enter the program mode. This feature runs the conveyor when making the spinner min and max trim settings (see menus 18,19) or Lane Width settings (see menus 32-38).

Press-n-hold Feed knob, adjust Lane knob to set the percentage of conveyor drive desired for dumping material onto the spinner. range (1 – 99%). The display starts out with three dashes **---**, denotes the conveyor active mode is **off**.

31 Max Lane selection The Max Lane selection establishes how many Lanes will be allowed for the operator. The AS3 is factory set with nine lanes evenly distributed between min to max. The AS3 will automatically redistribute the individual Lane Width settings evenly across the active number of lanes. This redistribution will only occur when the Maximum Lane selection is changed. After the Max Lane selection the installer can individually change any spinner speed using the menu list below. Recall Lane settings for knob positions 1 and 9 are set using menu 18 and 19.

Enter the number of lanes you want available to the operator into menu 31. The range is from 2 lanes to 9 lanes. **Factory = 9 lanes**

Example; Enter a setting of 5 to remove lanes 6,7,8,9.
The 5 active lanes are now: 1, 2, 3, 4, 5

Lane Width Since the AS3 starts out w/ automatically assigned spinner speeds it's the installers option to change these to more accurate spinner speeds. To change an individual Lane setting, first, press-n-hold the Feed knob, observe both the spinner and conveyor (if menu 30 is active) outputs go active. With the Feed knob held in, turn the Lane knob to change the spinner speed. Release the Feed knob to store your new setting. The display always shows the spinner drive as a percentage.

Note; the first (lowest) lane number is always one, Lane 1 is set using menu 18 and the largest lane number is always set using menu 19

Menu #	Name	Description	factory (9 lanes)
18	lane 1	min trim	---- by definition is 0%
32	lane 2	enter new %	12%
33	lane 3	enter new %	25%
34	lane 4	enter new %	37%
35	lane 5	enter new %	50%
36	lane 6	enter new %	62%
37	lane 7	enter new %	75%
38	lane 8	enter new %	87%
19	lane 9	max trim	---- by definition is 100%

Start up presets and multiple product calibration

Menu #	Name	Description
Start up		The AS3 allows the installer to define some start up settings. The factory have the AS3 power up in Automatic spreading mode with both Feed Rate and Lane Widths = zero (outputs off). This is the safest arrangement since it requires the operator turn at least one knob before spreading can occur.
39	<u>Manual / Auto mode</u>	enter the spreader mode that the AS3 will start from at power up Au t (automatic mode) An U (manual mode) factory = Au t
40	<u>Startup Feed Rate</u>	enter the startup Feed Rate that the AS3 will start from at power up [range 0 – 9] factory = 0
41	<u>Startup Lane Width</u>	enter the startup Lane Width that the AS3 will start from at power up [range 0 – 9] factory = 0
Products		The AS3 allows the operator to select from four granular products. The AS3 names the products 1, 2, 3 and 4. Product 1 is the granular material used for the primary conveyor calibration (weight/time dump). The other three products are defined simply as a ratio of the calibrated material weight and the weight of the alternate product. An easy method for determining the ratio is to use a simple bathroom scale and a 5 gallon bucket. Fill the 5 gal. bucket full and flush to the top and weigh it for Products 1-4. Use the formula below to calculate each product ratio, enter these ratios using menus 42-44. To effectively turn off a product, enter a ratio of 1.00 $\text{Product ratio} = \frac{\text{weight of Prod. (2,3,4)}}{\text{weight of Prod 1}} \quad \text{range (0.1 to 5.00)}$ <p>Example; Product 1 is sand weighing 75 lbs and product 2 is a sand/salt mix weighing 62 lbs. $62 / 75 = .826667$ (rounded = 0.83). Enter 0.83 into menu 42. Product 2 is selected for dumping the sand / salt mixture.</p>
42	<u>Prod 2</u>	enter ratio factory 1.00
43	<u>Prod 3</u>	enter ratio factory 1.00
44	<u>Prod 4</u>	enter ratio factory 1.00
45	<u>Liquid drive mode</u>	OL t sets liquid drive voltage control <u>sel. for liquid solenoid valve</u> Cu r sets liquid drive current control <u>future use only, do not use</u> OFF turns liquid channel off factory = OFF
		note: the liquid output for the AS3 currently only supports a solenoid (bang-bang) liquid valve. If you're not using the liquid output its very important to select the Liquid drive mode OFF . If the liquid output is used to turn on a 24P or a solenoid valve, select the OL t option. Do not use the Cu r option, this is reserved for a future PWM liquid drive option.
46-49		not assigned in this version

Spreader Cable Connections

The AS3 uses a 9 pin circular twist lock connector. The following table shows the connector pin out, name and description.

Pin no.	Circuit Name	Description
1	aux. input 2	Digital input, device sinking
2	valve supply (out)	12vdc valve supply, fused, common to all valve coils
3	output 3 (*)	Liquid valve solenoid drive signal
4	output 2	Spinner valve PWM drive signal
5	aux. input 1	Digital input, device sinking, (remote start option input)
6	vehicle power	+ 12vdc w/ a 5 amp feeder circuit, disconnect sw. by customer (**)
7	output 1	Conveyor valve PWM drive signal
8	mph input	vehicle speed signal, sensor types: AC, ACd, DC, DCn
9	vehicle ground	ground (neg.)

(*) The standard spreader control pin out for *Motiv* spreader controls assigns pin 3 as the 12vdc supply for the mph speed sensor. However, on the AS3, pin 3 is reassigned as the liquid output. All three outputs of the AS3 are low-side switching.

(**) The customer is to supply an emergency shut-off disconnect switch to ensure the operator has a direct method to interrupt vehicle power to the AS3 and thereby immediately stop the three hydraulic functions, auger, spinner, liquid.

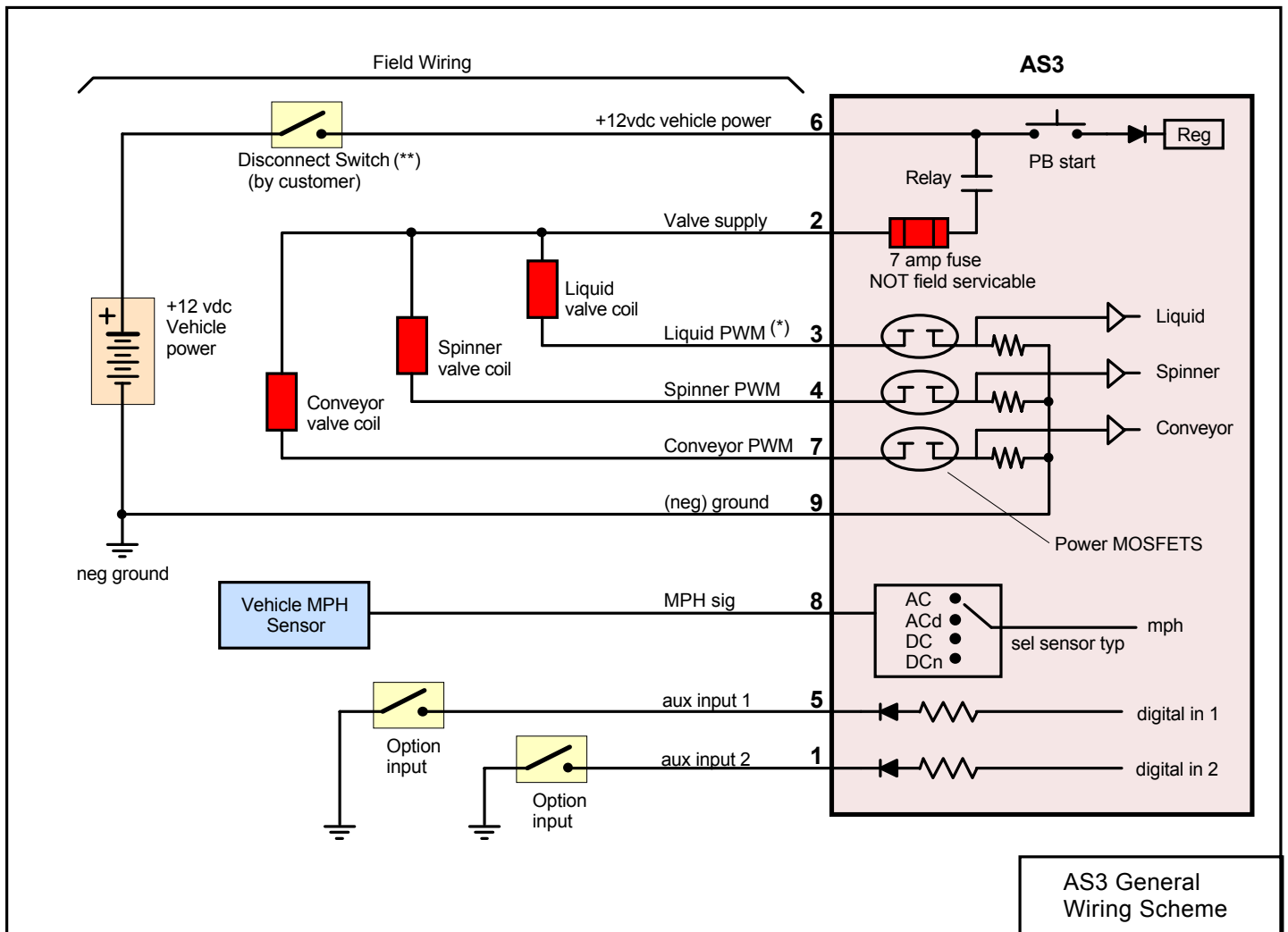

Front Panel Layout

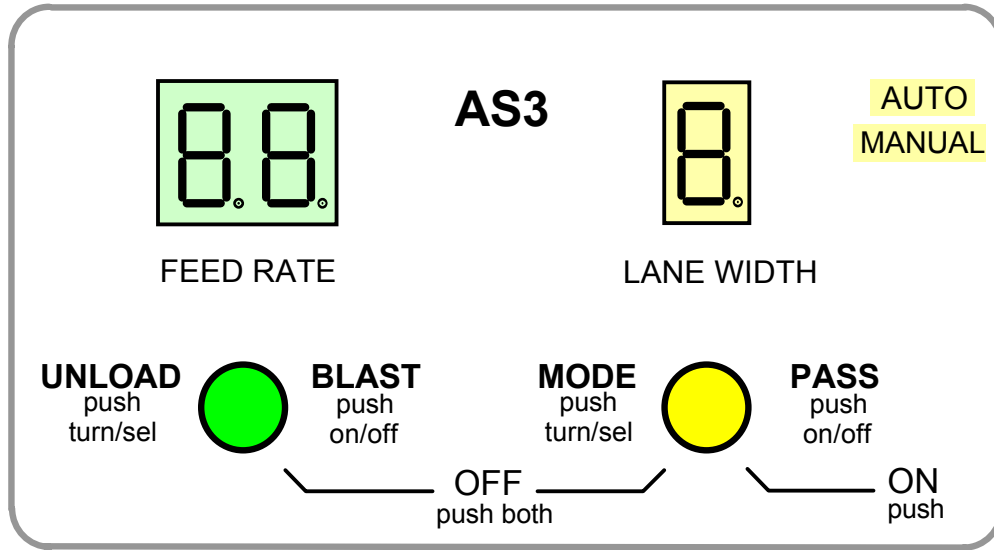

Dimensional outline

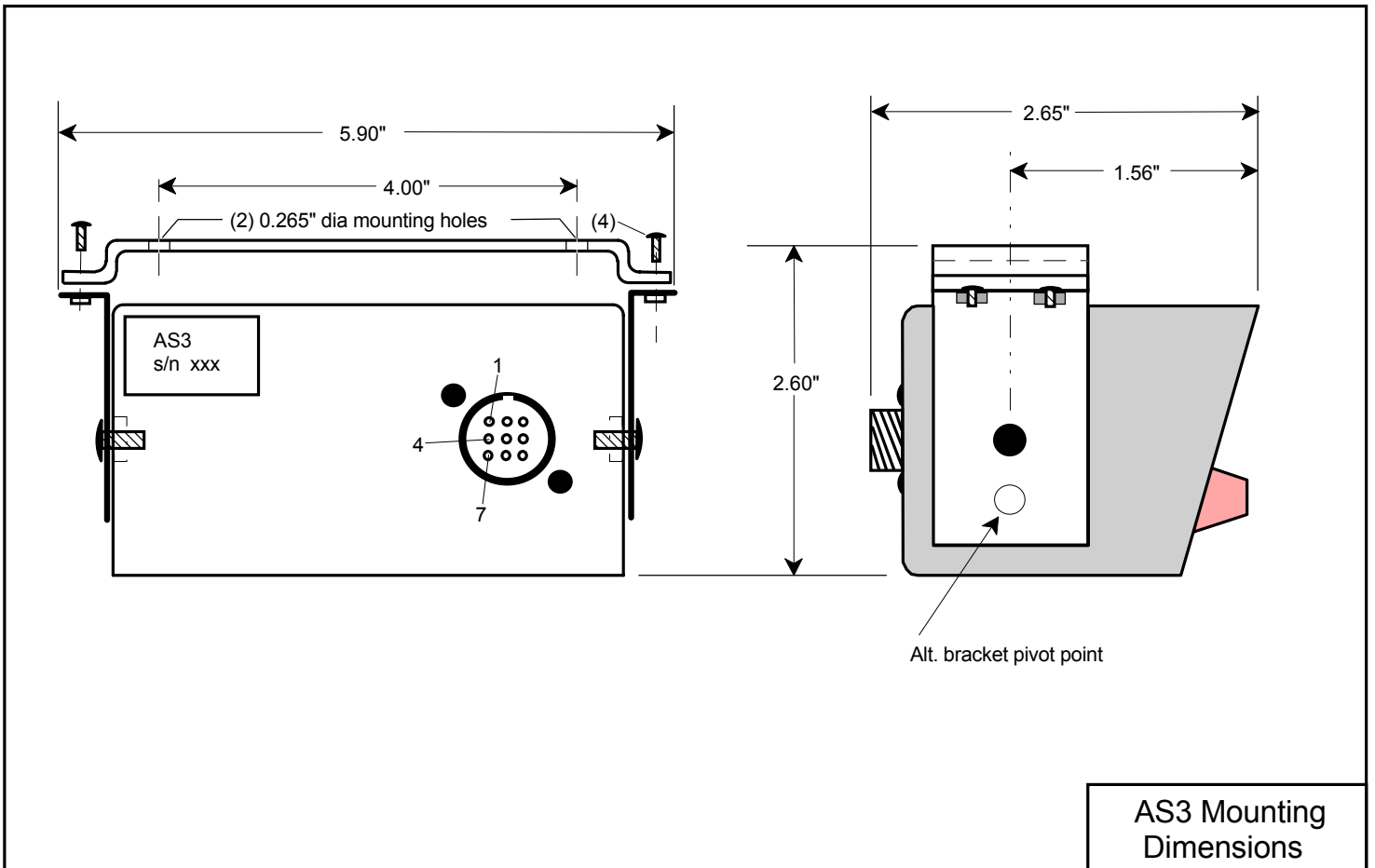

Mounting options

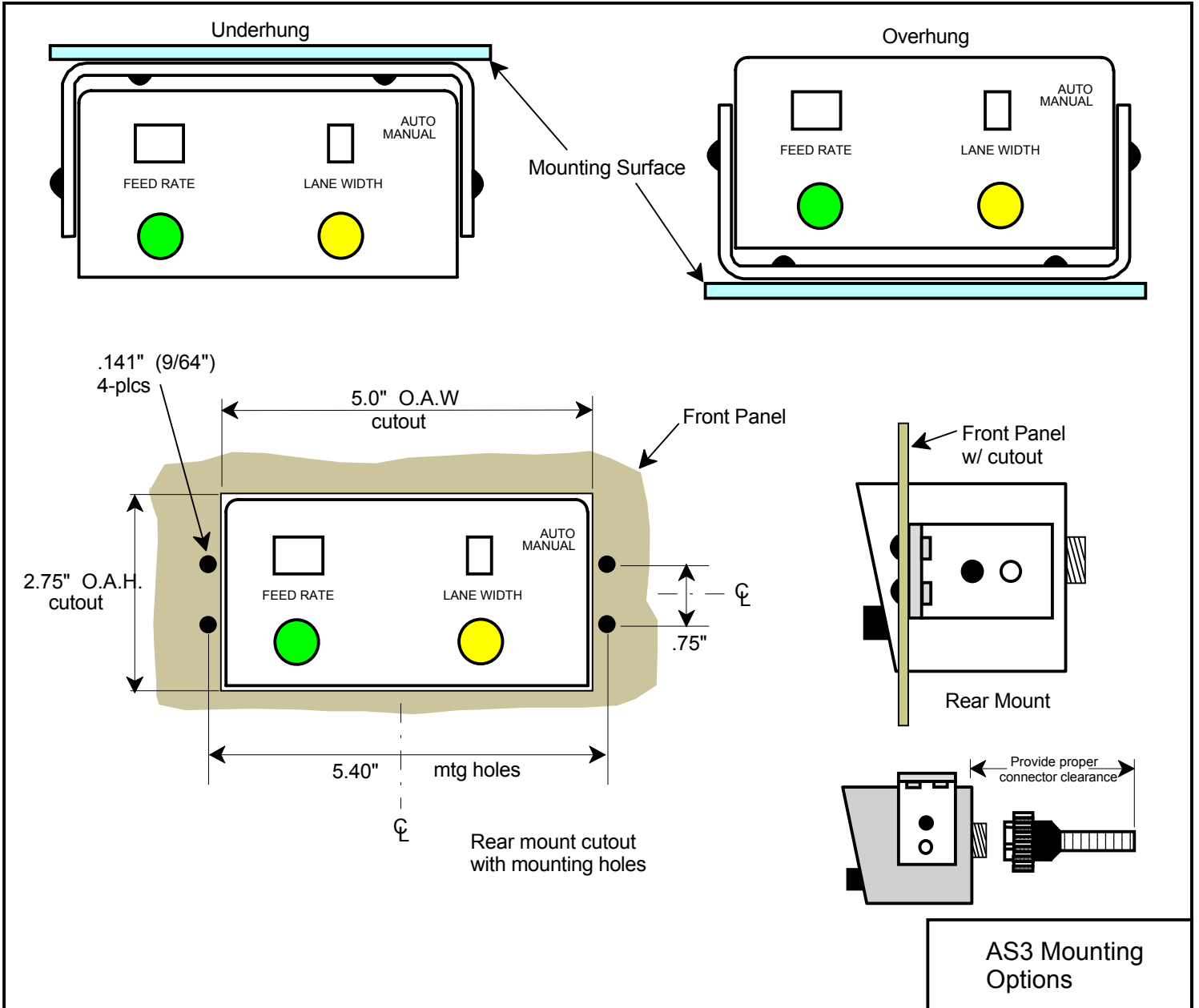

Application Note:

Liquid pre-wet using 24P01

Wiring connections for using a 24P and the AS3's liquid channel output. The AS3's liquid output provides power to the 24P. The liquid output drive mode is factory set = Off. To activate the liquid output use menu **45** to select the voltage drive mode. This allows the liquid output to go active (On) anytime the conveyor is active. The 24P provides the proportional drive to the liquid valve. Note, this method limits the liquid drive output current to 2.5 amps. If greater currents are required by the liquid valve use a relay.

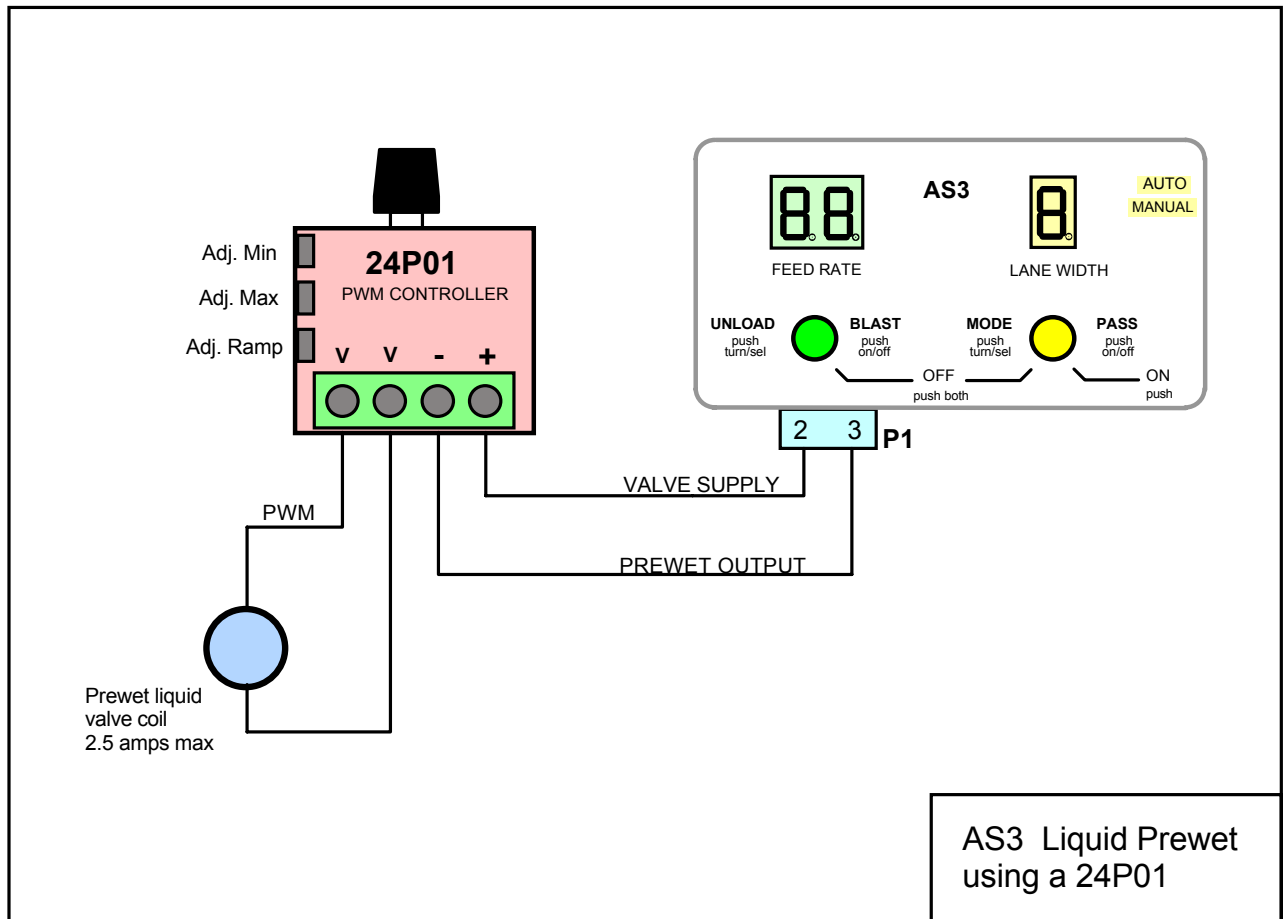

Program version log (valid as of the date of this publication)

The software version code for an individual AS3 can be viewed at menu 02.

----- *Begin B32 design s/n 0 - 150* -----

<u>Date</u>	<u>version no.</u>	<u>description</u>
3-18-02	D61	n/a
5-9-02	0A9	n/a
5-30-02	429	make spinner settings 1 & 9 = min & max
1-15-03	2B5	add conveyor and spinner presets, s/n, test menus
3-3-04	72E	allows factory test at 9 vdc
6-9-04	80A	adjust MPH to start at ½ mph
7-27-04	1d0	fix max trim to be greater than min trim, filter display current

----- *Begin rev 9S12 design s/n (151 - up) these code versions not-backward compatible* -----

<u>Date</u>	<u>version no.</u>	<u>description</u>
6-17-05	6E9	Upgrade CPU, all previous features were maintained.
6-24-05	26F	mod to current control, ref. current inrush
8-4-05	3E7	fix Blast-manual-external mode
12-22-05	045	add startup-beep, DL2 interface, inc. cts/mi to 200K, max lane limit
4-26-06	832	add more DL2 codes, add V-batt calib, fix liquid error trap
6-19-06	bd9	fix zero current read, test mode low volt error 08
7-17-06	800	fix low supply voltage calib for zero current
10-23-06	E51	add liquid mode sel: Off , Volt, cur. factory = Off

----- cut here -----

Program Access Pass Code

The AS3 requires the installer to enter an access pass code in order to make changes to any internal settings. If the installer or supervisor wishes to keep this code secret, remove this portion from the printed manual. The AS3 pass code is **8 5 4**

AS302 Field Note

10-29-08

This field note addresses a programming error that relates to the MPH sensor selection.

A recent change was made to the two front panel rotary switches. The new switches use fewer detents per revolution. The software was changed to accommodate these new switches.

However, unrelated to this required switch change, an error was introduced to the MPH sensor selection menu. Part of this error created incorrect labels and part associated the wrong labels with the sensor types.

This error only effected 8 units, s/n 677 - 684. The effected units do not need to be returned to the factory. Use the table below to associate the desired MPH selection with the menu label.

Steps

1. First verify the checksum (**CS**) of the program currently loaded into the AS3
CS 354 is the only version with this problem and **CS A4A** corrects the problem
2. Go to Menu No. 5

CS sensor type	354 wrong labels	A4A correct labels
VRM	dc	Ac
VRM-diff	dc n	Ac d
device sinking	b	dc
device sourcing	A	dc n

MPH display labels and descriptions

dc	device sinking, (DC hall-effect device)
dc n	device sourcing, (DC hall-effect device)
Ac	VRM normal mode
Ac d	VRM differential mode
b	incorrect label (display should read, dc)
A	incorrect label (display should read, dc n)

3. If you have **CS 354** use the **labels** listed in the table above
 - to select VRM, adjust the display to read **dc**
 - to select VRM-diff, adjust the display to read **dc n**
 - to select device sinking, adjust the display to read **b**
 - to select device sourcing, adjust the display to read **A**