



# ***SpreadSmart Rx<sup>TM</sup>*** **Operation Manual**

Configuration Log Page.....	5
Limited Warranty .....	6
Revision Level of this Manual .....	7
Package Contents .....	7
Functional Overview and Fundamental Operating Parameters .....	7
Open Loop or Closed Loop Spreading .....	7
Distance or Area Spreading of Granular Mat'l. with Proportional Gate .....	8
“Prescription Spreading” and/or “Operator Choice” Spreading .....	8
Temperature Response Spreading- Road Watch™ or CPI™ Sensor.....	8
Load and Rate Calculator.....	9
High Current Electric Pre-Wet Systems .....	9
Single or Two-Tier Anti-Ice System .....	9
Data Recording and <i>Drive by Download</i> ™ .....	10
Operating Functions Matrix – SpreadSmart Rx.....	10
Basic Operation Controls:.....	11
Startup Checklist – SpreadSmart Rx™ .....	11
Installation Steps .....	12
STEP 1 - Installation.....	12
Guard Against RF Interference .....	12
Installing the control unit.....	12
Connecting the cabling .....	12
STEP 2 – Power Verification.....	13
Multiple Uses of Switches: .....	13
STEP 3-Set up Wizard.....	13
STEP 4: “Un-Calibrated” Automatic Mode.....	14
STEP 5: Speedometer Calibration.....	14
STEP 6- Pre-Delivery Functional Test with Diagnostics .....	15
Using stored calibration files to configure multiple trucks.....	16
Post Delivery Steps .....	16
STEP A - Material Setup & Calibration .....	16
Material Setup .....	16
Granular Drop Test - Open or Closed Loop .....	16
Note that for maximum accuracy and performance, a drop test must be performed for each type of granular material (salt, sand, combinations, other material, etc.). .....	18
STEP B - Spinner Calibration with Granular Material.....	18
STEP C - Post Delivery Functional Test .....	19
Managing Materials – Granular, Pre-Wet and Anti-Ice .....	19
Choosing a material name and recording data: .....	20
Changing “Materials” program during normal operation.....	21
<i>Temp Response</i> ™ Prescription Set Up – for each material type.....	21
Using Preset Rates with Materials.....	23
Managing Information on SpreadSmart Rx™ .....	23
Battery Backup for Date and Time.....	24
Accessing Storm and Season Totals (SST) from <i>SpreadSmart Rx</i> ™ .....	25
Downloading Storm and Season Totals (SST) from <i>SpreadSmart Rx</i> ™ .....	25
Re-Setting Totals (SST) on <i>SpreadSmart Rx</i> ™ .....	26

Other Downloads – Calibration/System Settings Data.....	26
Operational Modes - Description .....	27
Accessing the “Mode” Screens .....	27
Automatic Mode – Ground speed oriented.....	27
Alarms.....	28
Manual Mode – Ground speed triggered .....	28
No Speedometer Mode – Ground speed simulated .....	29
Testing the Boom Tiers using No Speedometer Mode.....	29
Test Mode – No ground speed interaction.....	30
Unload Mode – Granular or Anti-Ice .....	30
Using Unload Mode to Re-circulate the material in the anti-ice tanks .....	30
Contrast.....	31
Speedometer with Re-settable Odometer (miles & feet) .....	31
Material.....	31
Fill Tank.....	31
Common Methods of Operation in Automatic Mode .....	31
Using Named Materials with Flexible Rates: .....	31
Using Named Materials/Rates with no changes allowed: .....	32
Using Named Materials with Programmed Rate Change Increments: .....	32
Load and Rate Calculation.....	32
Operating Instructions- Other Settings .....	35
Other Settings- Return to Set Up Wizard .....	35
Configuration of System without using Set up Wizard.....	36
Summary of Setup Parameters .....	36
Auger / Conveyor Set up and Trimming .....	38
Spinner and Zero velocity Set Up and Baseline Trimming .....	40
Pre-Wet Pump Set up and Trimming .....	42
Anti-Ice System – Configuration and Trimming Steps .....	44
Validation of Flow Meter Ratings using SpreadSmart Rx .....	46
Granular Calibration Validation.....	47
Optional Equipment.....	48
7 and 10” Camera Ready Color TFT Display – Touch screen .....	48
In Dash Mount on International Cabs.....	49
Temperature Sensor .....	49
GPS Receiver – for position and/or speedo signal source .....	49
Drive by Download™ (DBD) – See DBD 3.x operation manual .....	49
Material Detection Module™ (MDM) .....	50
Automatic Proportional Gate Control Instructions .....	53
Direct Cast Control Instructions.....	56
Backup Camera Instructions .....	59
Granular Material Switching Using the MDM Module .....	61
7 Inch Touch Screen Calibration Instructions.....	61
7MATERIAL AUTHORIZATION s .....	63
SpreadSmart System Troubleshooting Guide.....	64
Diagnostics – on board .....	66
Glossary of Terms .....	66

Appendix A: System Drawings.....	68
Appendix B: Spare parts list .....	68
Appendix D – Typical Frequency Settings by Valve Mfg .....	68
Appendix E – Anti-Ice Flow and Boom Arrangement.....	69



## **Configuration Log Page**

Use this page to log your system configuration information. Store in a safe place.

### ***SpreadSmart Rx*<sup>TM</sup> System**

Today's Date: \_\_\_\_\_ Information logged by \_\_\_\_\_

***SpreadSmart Rx*<sup>TM</sup> Serial #** \_\_\_\_\_

Hydraulic Valve Type \_\_\_\_\_

Coil Frequency \_\_\_\_\_

### **Granular System Capacity**

Auger Sensor Pulses per Pound (kg) \_\_\_\_\_

### **Pre-Wet System Capacities**

Pre-Wet Tank Volume (gallons or liters) \_\_\_\_\_

Pre-Wet Pump Max Volume Rating (gpm or lpm) \_\_\_\_\_

Flow Meter (sensor) Rating (pulses/gal or liter) \_\_\_\_\_

### **Anti-Ice System Capacities**

Anti-Ice Tank Volume \_\_\_\_\_

Anti-Ice Pump Max Volume Rating \_\_\_\_\_

Tier 1 (Low Flow) Boom Rating (max gpm) \_\_\_\_\_

Tier 2 (High Flow) Boom Rating (max gpm) \_\_\_\_\_

Flow Meter (sensor) Rating (pulses/gallon) \_\_\_\_\_

## **Limited Warranty Cirrus Controls LLC.**

### **What and who is covered?**

This warranty covers all defects in materials or workmanship in your Cirrus Controls system under normal use, maintenance and service. This warranty coverage applies only to the original owner and is not transferable.

### **How long is the warranty period?**

This warranty coverage runs for a period of 1 year from the date of initial installation (or 13 months from date of shipment from Cirrus Controls), whichever occurs first. Replacement parts are warranted for the remaining portion of the original warranty period or thirty (30) days from date of shipment from our factory (whichever is greater).

### **How can you get service?**

Cirrus Controls' obligation under this warranty is limited to repairing and/or replacing, at Cirrus Controls' option, any part or parts that are determined, by Cirrus Controls, to be defective. To be eligible for any claim under this warranty, the owner (or Cirrus authorized dealer) must return any defective part(s) to the factory, within the applicable warranty period (as set out above).

### **What will we do?**

Cirrus Controls' may, at its option, elect to grant adjustments in the field through an authorized representative and may thereby elect to waive the requirement that parts be returned to Cirrus Controls' factory. The repair or replacement of defective parts under this warranty will be made without charge to the owner except for transportation of the part to our authorized repair location.

### **What is not covered under this warranty?**

Cirrus Controls will not assume any expense or liability for repairs made outside our plant without our prior written consent. We are not responsible for damage to any associated equipment or product and will not be liable for loss of time, profit, inconvenience, commercial loss or direct consequential, special or incidental damages.

The provisions of this warranty do not apply to any product or parts which have been subject to misuse, negligence or accident, or which have been repaired or altered outside of Cirrus Controls' factory in any way (in the judgment of Cirrus Controls) so as to affect adversely its performance or reliability. Neither does this warranty apply to normal maintenance service and parts or to normal deterioration due to wear and exposure.

This warranty is expressly in lieu of other warranties, expressed or implied, in fact or by law, including any implied warranty of merchantability of fitness for a particular purpose. The remedies of repair or replacement as set forth are the only remedies under this warranty, Cirrus Controls' disclaims any obligations or liability for loss of time, profit, inconvenience, commercial loss or direct consequential, special or incidental damages. This warranty is in lieu of any other obligation or liability of Cirrus Controls' of any nature whatsoever by reason of the manufacture, sale, lease or use of such products and Cirrus Controls neither assumes, nor authorizes anyone to assume for it, any other obligation or liability in connection with such products.

## **Revision Level of this Manual**

At the time of release, this manual was accurate, but Cirus Controls reserves the right to make revisions and alterations to this manual from time to time without notice.

<u>Rev Letter</u>	<u>Date</u>	<u>Detail</u>
X	3/8/11	General Update
Y	2/16/12	Proportional Gate Update
Z	7/2/12	Camera Ready Display added as option
AA	8/23/12	Updated password options; Touch screen updates
AC	5/10/13	Changed Pass to Pass (Pause)
AD	3/7/14	Added Granular Calibration Validation/Touch Screen Cal
AE	11/5/14	Added Preset Rates, Granular MDM Switching, Booms on/off
AF	11/12/14	Further Preset Rates Updates
AG	4/7/16	UTC clock, material authorization and wifi SD updates

## **Package Contents**

A complete *SpreadSmart Rx*<sup>TM</sup> spreader control system contains the following items:

- 1) *SpreadSmart Rx*<sup>TM</sup> control unit
- 2) Keypad mounting bracket and grip nuts (when keypad is not in arm unit)
- 3) This manual
- 4) Power Cable, Speedometer/Remote Blast/Pass(Pause) Cable
- 5) Hydraulic control cable (s)
- 6) Sensor Cable(s): defined as part of your system configuration;

If any of these items are missing, please contact your distributor immediately for replacement.

## **Functional Overview and Fundamental Operating Parameters**

The *SpreadSmart Rx*<sup>TM</sup> spreader control is a simultaneous three media (granular, pre-wet and anti-ice), ground speed oriented closed loop system. It is designed to accurately control multiple application rates based on ground speed and sensor feedback. Installations may run the auger and pre-wet pump in closed or open loop configuration. The system is also capable of controlling a closed loop spinner and complete, 3 boom anti-ice systems simultaneously. The system is designed to be “set it and forget it”, where the operator sets the application rates and the system does the rest, starting and stopping dry, pre-wet and anti-ice applications as the vehicle starts and stops, and varying the auger speed and pre-wet/anti-ice pump rates as the vehicle speeds up and slows down to deliver consistent material per lane mile traveled.

## **Open Loop or Closed Loop Spreading**

*SpreadSmart Rx*<sup>TM</sup> is designed to spread granular and /or liquid material with feedback sensors: “Closed Loop operation” or without: “Open Loop operation.” Use of feedback sensors allows *SpreadSmart Rx*<sup>TM</sup> to actually measure output and compare it to signal output to make real-time adjustments for more consistent control throughout the range of operating conditions.

Selecting Closed Loop Operation: during Setup wizard for each device (auger, spinner, pre-wet, and anti-ice) the choice of “**Sensor Present – yes**” results in closed loop operation for the system must be selected. A choice must be made for each device. Sensor types for closed loop systems vary. See Attachment A for a drawing to set pull up resistors if non-standard sensors are used. Factory defaults are shown.

Selecting Open Loop Operation: during Setup wizard for each device (auger, spinner, pre-wet, and anti-ice) the choice of “**Sensor Present – no**” results in open loop operation for the system selected. A choice must be made for each device.

**NOTE: we do not recommend that open loop operation be used as the normal operating mode for pre-wet or anti-ice systems since that choice over-rides the pump protection that would prevent a pump from running dry and damaging it.**

## **Distance or Area Spreading of Granular Mat'l. with Proportional Gate**

When setting up the auger/conveyor section of your system, select the method that causes the controller to manage the amount of material spread by:

- a) **Pounds (Kg) per Mile(Km) Driven = Distance Spreading.** the controller manages the material released by the auger/conveyor. The operator controls spinner speed and therefore the “spreading pattern” occurs as the operator has set it. Material dispensed will correlate to ground speed and distance traveled, but is not spread in a uniform thickness over the road at any speed.
- b) **Pounds (Kg) per Lane Mile (Km) Driven = Area Spreading.** In this format, the controller manages the material released by the auger/conveyor as well as controlling the spinner speed needed to disperse material uniformly within the lane width specified (0.1 lanes up to 3.0 lanes in 0.1 lane increments). Auger and spinner speeds are controlled and both correlate to ground speed and distance traveled resulting in a uniform thickness of material spread regardless of ground speed during spreading.
- c) **Proportional Control of hydraulically powered rear gate on conveyor is optional.**

## **“Prescription Spreading” and/or “Operator Choice” Spreading**

For users who want to follow specific spreading methods, SpreadSmart offers a wide array of definable spreading prescriptions to allow users to precisely manage their spreading parameters. Detailed instructions are included in “managing materials.”

- a) Invoice by assigning different spreading prescriptions for different jurisdictions. Define your spreading prescriptions/categories so you'll always know how much material was dropped on federal roads, state roads, county roads, municipal roads and private roads. Be able to track total material spread as well as each individual category of materials spread.
- b) Unique calibration settings named for wet or dry material: Since wet material weighs more than dry material, spread amounts per revolution of the auger will vary if material is wet or dry. This problem is correctable if the calibration values take actual material weight into account. Naming each granular material calibration to correlate to the conditions under which granular material is stored improves the accuracy of data collected during spreading.
- c) Uniform vs. Preset Rate Increments: Uniform rate increments rely on a preset interval while changing spreader rates between a minimum and a maximum spreading value. Preset rates provide for non uniform intervals on rate changes by pre-configuring dispensing rates for each material.

## **Temperature Response Spreading- Road Watch™ or CPI™ Sensor**

**SpreadSmart Rx™** offers the user the opportunity to control all spreading parameters in direct response to changes in measured road temperature. By correlating up to (5) spreading prescriptions to each of (5) temperature ranges for which those prescriptions apply, the anti-icing and de-icing performance is optimized. See System Setup and **Temp Response™** Settings in the Materials section for detailed setup instructions.

## Load and Rate Calculator

*SpreadSmart Rx*<sup>TM</sup> allows operator to calculate, properly load liquid and granular materials on spreading vehicles and set the liquid and granular rate(s) to:

- 1) **Fully consume the maximum amount of pre-wet salt brine capacity on a vehicle** for a given length of route.
- 2) **Use Anti-icing tanks (on board or pulled with trailer) simultaneous with granular and pre-wet systems and fully consume the loaded liquid.**
- 3) Using the amount of salt brine available on a fully loaded truck, **calculate the amount of dry granular salt material to load onto that truck to deliver a particular total amount of salt** for the planned route
  - a. **(Total salt pounds for route = liquid salt + granular salt).**

## High Current Electric Pre-Wet Systems

The pre-wet channel on *SpreadSmart Rx*<sup>TM</sup> is rated for a maximum current capacity of 6 amps. If you are using an electric pre-wet pump that is rated for higher source current levels, contact Cirrus Controls for the Electric Pre-Wet Driver accessory module.

## Single or Two-Tier Anti-Ice System

The *SpreadSmart Rx*<sup>TM</sup> anti-ice system offers automatic integration of two tier dispensing of anti-ice liquids. By choosing the boom and its nozzles with specific flow rates in mind, the system offers a wide range of material delivery capability. The anti-ice system automatically recognizes when the controller asks for output rates that require the output of the Low Flow Tier 1 boom alone, the High Flow Tier 2 boom alone or the combination of Tiers 1 & 2 (note: Tier 1 is set up with the lowest output nozzles and tier 2 with the highest output nozzles). Nozzles are chosen so as not to overlap output rates between booms. AI Power Module allows the SS Rx to switch power to the high current lines for the boom valves.

### Details for Single Tier Anti-Ice System

*SpreadSmart Rx*<sup>TM</sup> will also operate an anti-ice system with a single row of dispensing booms (one, two or three for left, right and center dispensing). To configure the *SpreadSmart Rx*<sup>TM</sup> for a system with a single tier, answer “yes” to single tier relay as described below and verify that the boom valves are wired to the tier 1 output signals.

Boom Rating Maximum	Flow Rate Range	Max Gallons/Lane Mile @ 60mph
Tier 1- Low Volume	0 - 8 GPM	8 GPLM (= 8 GPM)
Tier 2- High Volume	8 - 48 GPM	48 GPLM (= 48GPM)
Tier 1 + Tier 2 (total)	48-56 GPM	56 GPLM (= 56GPM)

Note: the gallons per lane mile output at which the system switches between tiers is dependent upon the boom rating of each tier.

System capacity required (GPM) for single lane application at various rates and speeds.

Gallons per lane mile (GPL-M)	60	5.0	10.0	15.0	20.0	25.0	30.0	35.0	40.0	45.0	50.0	55.0	60.0
	55	4.6	9.2	13.8	18.3	22.9	27.5	32.1	36.7	41.3	45.8	50.4	55.0
	50	4.2	8.3	12.5	16.7	20.8	25.0	29.2	33.3	37.5	41.7	45.8	50.0
	45	3.8	7.5	11.3	15.0	18.8	22.5	26.3	30.0	33.8	37.5	41.3	45.0
	40	3.3	6.7	10.0	13.3	16.7	20.0	23.3	26.7	30.0	33.3	36.7	40.0
	35	2.9	5.8	8.8	11.7	14.6	17.5	20.4	23.3	26.3	29.2	32.1	35.0
	30	2.5	5.0	7.5	10.0	12.5	15.0	17.5	20.0	22.5	25.0	27.5	30.0
	25	2.1	4.2	6.3	8.3	10.4	12.5	14.6	16.7	18.8	20.8	22.9	25.0
	20	1.7	3.3	5.0	6.7	8.3	10.0	11.7	13.3	15.0	16.7	18.3	20.0
	15	1.3	2.5	3.8	5.0	6.3	7.5	8.8	10.0	11.3	12.5	13.8	15.0
	10	0.8	1.7	2.5	3.3	4.2	5.0	5.8	6.7	7.5	8.3	9.2	10.0
	5	0.42	0.83	1.25	1.67	2.08	2.5	2.92	3.33	3.75	4.17	4.58	5.0
			5	10	15	20	25	30	35	40	45	50	55

Colored boxes indicate which boom tier is in operation at any particular combination of MPH and GPL-M settings. Color and Tier reference is above. For multiple lane system capacities, multiply the single lane capacity by the total number of lanes required.

Table 1

Ground speed (mph)

### Data Recording and Drive by Download™

SpreadSmart™ automatically records spreading data and other sensor data (GPS, Temperature, pressure, etc) and with the addition of Drive by Download™ option, can automatically download the complete data set. See Optional equipment section for more detail.

### Operating Functions Matrix – SpreadSmart Rx

Desired Function Control	Operating Mode	Notes
<b>Normal Operation</b>		
Normal operation with spreading data collection and ground speed orientation;	Use Automatic Mode	Normal operating mode; System powers up with “pass (pause) on” as the default setting;
“Pause” normal operation,	Select “pass (pause)” to turn on, select again to turn off,	Rates may be changed while in pass (pause) mode.
Spread at Max. Rate temporarily	Select “blast”	Timed or “latched on” modes
Operation with operator settings and ground speed triggering; data is not recorded.	Use Manual Mode	Operating mode – ground speed triggered, must have valid ground speed signal to operate.
Simulated automatic operation without ground speed input (signal or motion of	Use No Speedo Mode	Operating Mode – does not require ground speed signal.

truck). Spreading data is recorded.		
Unload Granular Material	Use Unload Mode	Operating Mode
Unload Anti-Ice Tank	Use Unload Mode	Operating Mode
Changing Materials	Use Materials Screen	Set Up step
<b>System Setup and Testing</b>		
Technician test of system function with feedback;	Use Test Mode	Used for initial setup; Use as operating mode with no ground speed signal
Validate multi-tier Anti-Ice system in a stationary truck;	Use No Speedo Mode	Used for initial setup;
<b>Special Operations Choices</b>		
Dispense Material while truck is stopped – dispensing ceases automatically when truck moves;	Use Unload Mode	Special Operation
Automatic spreader operation without truck wheels turning.	Use No Speedo Mode	Operating mode, simulates truck speed,
Re-Circulate A.I. Tank	Use Unload Mode	Stationary Truck,

**SpreadSmart Rx™ LCD**



**Switch Panel**



**Electronics (CPU)**



**Basic Operation Controls:**

- 1) **Power switch** in the upper left corner controls the power to the unit and all electrical connections made to it.
- 2) **Dry, Pre-Wet and Anti-Ice** each has individual on/off switches.
- 3) **Anti-Ice Booms** have individual on/off controls for each of the three booms.
- 4) **Auger, Spinner, Pre-wet and Anti-Ice up/down paddles** control the application rate in various run modes. The spinner doubles as a switch used to navigate the menu functions.
- 5) **Blast/Pass (Pause) Toggle** has the dual use for navigating menus and for Blast/Pass (Pause) function.
  - a. Pass (Pause) is a simple pause function making no changes to settings.
  - b. Pass (Pause) is automatically engaged after a power cycle to avoid accidental spreading.
- 6) **Backlit graphic LCD** screen displays settings, menu items and material outputs.

**Startup Checklist – SpreadSmart Rx™**

Step	Task	Completed by:
1	<b>Installation</b> - Mount the control unit in the truck cab and connect hydraulic control cable, sensor cable, power and speedometer cable to the appropriate valve coils and feedback sensors;	
2	<b>Power Verification</b> – power up the unit and verify that the LCD displays the Setup Wizard. Wait to perform the wizard until all hydraulics and spreader hardware is installed in the truck. At this point, no other functions are possible until all hydraulic systems are installed in the truck.	
3	<b>Set Up Wizard:</b> follow the step-by-step controller instructions to: a)	

	enable the systems installed in the truck (auger, spinner, pre-wet, anti-ice, sensors, etc); b) complete “pre-delivery trim” of the selected hydraulic systems.	
4	<b>“Un-calibrated” automatic mode</b> - Choose “yes” when asked to run un-calibrated; Normally, trucks are delivered to customers without performing drop test calibration. Note: if unable to get into “un-calibrated” automatic mode, step 3 needs to be verified and/or repeated.	
5	<b>Calibrate Speedo</b> - Verify speedometer signal input to the spreader and choose system set up, trims/cal to calibrate the spreader speedometer to match the truck speedometer.	
6	<b>Pre-Delivery Functional Test</b> – Using No-Speedo mode, test and verify ground speed operation, off rate indications, and alarms.	

**Post Delivery Steps:**

A	<b>Truck ID, Material Setup</b> - Input truck ID, program up to (10 each) Granular, Pre-Wet and Anti-Ice material names to establish operational parameters for granular, pre-wet and anti-ice systems.	
B	<b>Drop Test Calibration of Auger and Spinner</b> – Load truck with granular material and perform drop test calibration (Closed or Open Loop) for each Granular material customer defined.	
C	<b>Post Delivery Functional Test</b> - Verify that the system functions properly and is stable at the ground speed and material delivery rates the customer desires;	

## Installation Steps

### STEP 1 - Installation

#### Guard Against RF Interference

Even properly guarded sources of radio frequency (rf) noise can “leak” and interfere with in-cab electronics. Take care when installing radios and radio antenna cable to keep at least 12” spacing between them and any cabling for the *SpreadSmart Rx*™. Take particular care with *SpreadSmart Rx*™ installations that have dash mounted LCD’s.

#### Installing the control unit

The control unit should be mounted in a position where the display is easily seen (often on the dash board) and the operator can easily reach the controls of the unit. It should not, however, be mounted in a position such that it interferes with the drivers line of sight of the roadway.

#### Connecting the cabling

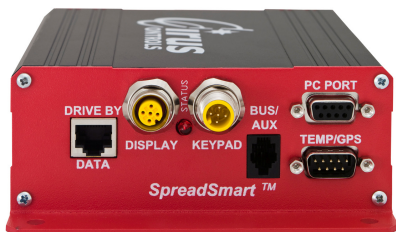

**CPU for Keypad interface**



**CPU for Touch Screen Interface**



Connections for Power (connect to ignition hot source), 5/12v switch for sensors, Aux for WiFi bridge power, Hydraulics, Anti-Ice booms, Sensors and speedo/remote blast/ pass (pause) switches.

Connections: Drive by Data, Temp/GPS, LCD display, Bus, PC & keypad.

## STEP 2 – Power Verification

At this stage, the system can be powered up to verify electrical connections, but will not operate the hydraulics until the Set up Wizard is complete.

Turn on the power switch on the keypad. The unit should start up, lighting the display, displaying the *SpreadSmart Rx™* logo, and after a couple seconds will display the Set Up Wizard intro screen.

```
Pre-delivery setup has not been comple-
ted. The spreader will now enter the
setup wizard to prepare the system for
delivery. Please follow the prompts on
the screen to complete pre-delivery
setup.
<PASS>=next
```

## Multiple Uses of Switches:

To keep the operator interface easy to use, the *SpreadSmart Rx™* makes multiple uses of the keys on the switch panel. The label on the key panel indicates the use of the switch during normal operation. Included throughout this manual are multiple uses of some of the switches for programming and set up of the system. In all cases, the switches are referred to by the name that appears next to them on the switch panel.

## STEP 3-Set up Wizard

<b>WARNING</b>		<p>Potential for injury due to unexpected startup or movement of mechanical equipment.</p> <p>Unexpected startup or movement of mechanical equipment may cause injury to eyes and extremities.</p> <p>During initial startup and testing, the spreader components may start without warning. Stay clear of the auger, spinner, and liquid nozzles until initial power up and programming are complete.</p>
----------------	---	--

The *SpreadSmart Rx™* system must be configured and trimmed before it can be run in automatic mode. Prior to initial operation, following the Set up Wizard will set the basic operating parameters. The settings chosen in this procedure affect all aspects of system performance.

Set up Wizard is a step-by-step, menu driven sequence that allows you to configure the controller to match the equipment set on the truck and to run automatic trimming sequences to align the controller settings with the hydraulic system on the truck. After successful completion of the wizard, the truck will be ready to run, but will not be calibrated until the granular drop test and spinner calibrations have been complete. The Wizard will walk you through the following steps:

- 1) Password \_\_\_\_\_ to enter setup wizard;

```

Configuration
Enter Password:
      [*000]
<SPINNER +/-> to change
<BLAST>=back      <PASS>=next/done

```

```

Setup Wizard
Units:          Standard
<BLAST>=back  <SPIN+/->=adj  <PASS>=next

```

- 2) Select Units – standard or metric
- 3) PWM Frequency – match with coils on truck;
- 4) Systems Installed on Truck:
  - a. Auger, spinner, pre-wet, anti-ice;
- 5) Automatic Trimming:
  - a. For each system you enable (by answering yes) the set up wizard will give you the option to run automatic trimming. These steps should not be completed until all hydraulics are installed and ready to test.
  - b. Note: when trimming Anti-Ice system, turn all 3 boom valves on.
- 6) Press “pass (pause)” to complete, save configuration and re-start SpreadSmart Rx.
- 7) Choose to:
  - a. Complete Granular Calibration (completed by customer using his material).
  - b. Run System Un-Calibrated

To bypass the Wizard and leave the system un-configured, answer “no” to each of the four questions. The SpreadSmart will display the “mode” screen, but none of the output signals will function until turned on at a later time.

#### STEP 4: “Un-Calibrated” Automatic Mode

Choose “yes” when asked to run un-calibrated. Normally, trucks are delivered to customers without performing granular drop test calibration. Note: if unable to get into “un-calibrated” automatic mode, step 3 needs to be verified and/or repeated.

```

Granular Weight Calibration
This system is not weight calibrated.
Inaccurate dispensing will result from
running the system in this mode.
  → Perform Calibration Now
    Run System Uncalibrated
<SPINNER+/->=select      <PASS>=next

```

Note: this screen will re-appear every time the system is powered up until the granular calibration is satisfactorily completed, but only on controllers with the auger activated. It is not necessary to calibrate to run the system unless you are seeking accurate spreading amounts. This warning screen can be disabled by selecting the “perform calibration now” and pressing “pass (pause)” for every question asked until you reach a screen offering you the option to disable this warning by pressing “pass (pause).” (Selecting “pass (pause)” in this manner causes you to reach the end of the drop test without doing the test correctly). It is not recommended that you disable this warning.

#### STEP 5: Speedometer Calibration

The speedometer sensor emits a stream of pulses, which increase as the speed increases. The *SpreadSmart Rx*<sup>TM</sup> uses this information to determine speed, using a “pulses per mile” setting. This can be set either by driving the truck at 30 MPH (steady speed), by driving the truck over a known mile (fixed distance) or by “matching the truck speedometer.” Fixed distance calibration is more accurate, however, “steady speed” or “matching” calibration are quite a bit faster.

1) Enter configuration menu by simultaneously hold the auger and pre-wet switches down to enter the “configuration screen.” You will be asked for a password, enter “\_\_\_\_\_” using the spinner controls to change the digits, and the blast/pass (pause) controls to change cursor positions. Run the cursor past the end of the password to enter setup mode.

2) Use spinner switch, select “Trim/Cal”,

a) Use GPS as Speedo – answer yes if GPM antenna is source of speedo signal.

Default is “no” when you use the truck speedometer/transmission for speedo signal

b) Speedo Pulses / MI – hit pass (pause) to begin calibration of speedometer

### “Steady Speed” Calibration

- 1) Select speedometer calibration;
- 2) Select steady speed calibration;
- 3) Bring the truck to 30 miles per hour and remain at that speed;
- 4) Press pass (pause) to start calibration;
- 5) Calibration will complete after several seconds;

The unit will take several samples of the speed sensor output, average, and determine the number of pulses per mile. The whole process takes about 10 seconds.

### “Fixed Distance” Calibration

If using fixed distance calibration, the best method is to drive a mile using mile markers.

Although driving a mile in stop and go traffic would work, more accurate results are achieved if driving a steady speed on a highway.

- 1) Select speedometer calibration.
- 2) Select fixed distance calibration.
- 3) Once the instructions are on the screen, drive to the first mile marker and press pass (pause).
- 4) Drive to the next mile marker, and press pass (pause) again as the vehicle passes the marker.
- 5) The speedometer is now calibrated.

### “Match Truck Speedometer” Calibration

- 1) Select speedometer calibration;
- 2) Select match Speedometer calibration;
- 3) Bring the Truck to a steady, maintainable speed (10-30 mph);
- 4) Using the “spinner” switch, adjust the pulses per mile/km until the resulting mph/kph matches the value displayed on the truck speedometer.

Press “pass (pause)” to accept setting and return to Trim/Cal menu.

## STEP 6- Pre-Delivery Functional Test with Diagnostics

In No-Speedo mode or Test mode, operate and verify ground speed operation (auto or manual), warnings, and hydraulic functionality. Use Diagnostics from the Mode screen to trouble shoot problems.

Diagnostics	
→ Firmware versions	Automatic Mode
MMC/SD Data Card	MDM Module
GPS Antenna	Speedometer
RoadWatch	
<BLAST>=done <SPIN+/->=sel <PASS>=next	

## Using stored calibration files to configure multiple trucks

Once the set up wizard has been completed, the stored calibration file can be downloaded to your laptop computer and subsequently uploaded to a new truck before running the set up wizard. See “Other downloads” for instructions. Once upload is complete, power cycle the controller and the set up wizard will pass. Drop test calibration must still be completed.

## Post Delivery Steps

### STEP A - Material Setup & Calibration

#### Material Setup

Configure up to (10) Granular, (10) Pre-Wet and (10) Anti-Ice material names to establish operational parameters operation. See Managing Materials section for full instructions.

- 1) Enter configuration menu by simultaneously hold the auger and pre-wet switches down to enter the “configuration screen.” You will be asked for a password, enter “\_\_\_\_\_” using the spinner controls to change the digits, and the blast/pass (pause) controls to change cursor positions. Run the cursor past the end of the password to enter setup mode.
- 2) Using the spinner switch, select “Materials” to begin.

Configuration	
Setup Wizard	Advanced
System Setup	Set Clock
Trim/Cal	Reset All
→ Materials	Save and Exit

<BLAST>=done <SPIN+/->=sel <PASS>=next

## Granular Drop Test - Open or Closed Loop

<b>WARNING</b>		<p>Potential for injury due to unexpected operation of auger.</p> <p>Entanglement in the auger will cause severe injury to extremities, with possible loss of extremities.</p> <p>During initial startup and testing, the auger may start without warning. Stay clear of the auger during all startup, programming, and operation procedures.</p> <p>Do not attempt to clear a jammed auger with the hydraulic or control system active.</p>
----------------	---	--

With the auger, spinner, and pre-wet configured and trim values present, the *SpreadSmart Rx™* will operate in automatic. Until doing a material drop test, the unit will use default values and be less accurate.

#### Closed Loop Drop Test (auger/conveyor sensor present):

For accurate material delivery, a drop test must be performed for each named type of granular material.

**Conveyor Spreaders: accuracy is a function of the gate height settings on the truck.** If multiple gate settings are used in normal operation, a material name and drop test must be run for each gate setting (Salt 2, Salt 3, Salt 4 etc). **Changes in the gate setting without changing the calibration will result in less accurate dispensation of granular material.**

1) Enter configuration menu by simultaneously hold the auger and pre-wet switches down to enter the “configuration screen.” You will be asked for a password, enter “\_\_\_\_\_” using the spinner controls to change the digits, and the blast/pass controls to change cursor positions. Run the cursor past the end of the word to enter setup mode.

2) Using the spinner switch, select “Materials,” and select material type.

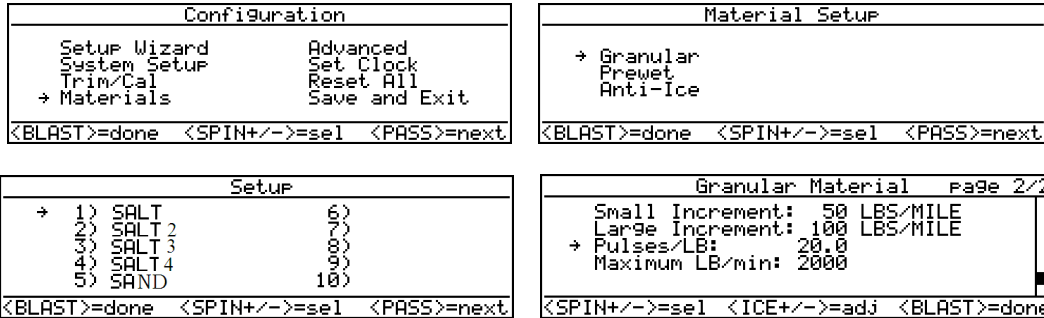

- a) Pick the material type you wish to calibrate (i.e. salt).
- b) Scroll down to pulses per pound.
- c) Press pass to select between calibration modes:
  - i) **Weigh Truck** (requires truck scales);
  - ii) **Weigh Material Dropped** (requires 75 lb. scale and bucket for weighing);
- d) Read the instructions and page through them using the pass switch.
  - a. **Weigh truck** – run the auger at 50% and unload at least a yard of material;
  - b. **Weigh Material** – run the auger at 50% and unload 300-500 lbs of material.
- f) Enter weight of material dropped.
- g) Accept the new calibration value in pulses/lb (note that max lbs/min is changed by the system as a result of the new value in pulses/lb).

**Drop Test is now complete for the material selected. Note that for maximum accuracy and performance, a drop test must be performed for each type of granular material (salt, sand, combinations, other material, etc.).**

### Open Loop Drop Test (no sensor on auger/conveyor)

A drop test must be performed for each named type of granular material (salt, sand, mixture, etc).

Drop tests performed on open loop systems will improve accuracy, but cannot achieve the accuracy of a closed loop system. In addition, accuracy of open loop system is dependent on the accuracy of the hydraulic trimming for the auger. Best trimming requires a hand held tachometer to properly identify the max rpm of the auger (and the max trim of the auger hydraulic channel).

**Conveyor Spreaders: accuracy is a function of the gate height settings on the truck.** If multiple gate settings are used in normal operation, a material name and drop test must be run for each gate setting (Salt 2, Salt 3, Salt 4 etc). **Changes in the gate setting without changing the calibration will result in less accurate dispensation of granular material.**

1) Enter configuration menu by simultaneously hold the auger and pre-wet switches down to enter the “configuration screen.” You will be asked for a password, enter “\_\_\_\_\_” using the spinner controls to change the digits, and the blast/pass controls to change cursor positions. Run the cursor past the end of the password to enter setup mode.

2) Using the spinner switch, select “Materials,” and select material type.

Configuration	Material Setup
Setup Wizard           Advanced System Setup         Set Clock Trim/Cal             Reset All → Materials           Save and Exit	→ Granular Prewet Anti-Ice
<BLAST>=done <SPIN+/->=sel <PASS>=next	<BLAST>=done <SPIN+/->=sel <PASS>=next
Setup	Granular Material page 2/2
→ 1) SALT                   6) 2) SALT 2               7) 3) SALT 3               8) 4) SALT 4               9) 5) SAND                 10)	Small Increment: 50 LBS/MILE Large Increment: 100 LBS/MILE Pulses/LB: 20.0 → Maximum LB/min: 2000
<BLAST>=done <SPIN+/->=sel <PASS>=next	<SPIN+/->=sel <ICE+/->=adj <BLAST>=done

- a) Pick the material type you wish to calibrate (i.e. salt).
- b) Scroll down to maximum LB/min.
- c) Press pass to select between calibration modes:
  - i) **Weigh Truck** (requires truck scales);
  - ii) **Weigh Material Dropped** (requires 75 lb. scale and bucket for weighing);
- d) Read the instructions and page through them using the pass switch.
  - a. **Weigh truck** – run the auger at 50% and unload at least a yard of material;
  - b. **Weigh Material** – run the auger at 50% and unload 300-500 lbs of material.
- e) Enter weight of material dropped.
- f) Accept the new calibration value in pulses/lb (note that max lbs/min is changed by the system as a result of the new value in pulses/lb).

Drop Test is now complete for the material selected.

**Note that for maximum accuracy and performance, a drop test must be performed for each type of granular material (salt, sand, combinations, other material, etc.).**

## STEP B - Spinner Calibration with Granular Material

<b>WARNING</b>		<p>Potential for injury due to unexpected operation of spinner.</p> <p>Granular material thrown off the spinner will cause severe eye injury, with possible permanent loss of vision. Contact with a moving spinner will cause injury to extremities and other body parts.</p> <p>During initial startup and testing, the spinner may start without warning. Stay clear of the spinner during all startup, programming, and operation procedures.</p> <p>Do not attempt to clear a jammed spinner with the hydraulic or control system active.</p>
----------------	---	--

The controller can be operated in **linear spreading mode (pounds per mile) or area spreading mode (pounds per lane mile)**. To accurately spread material over an area, spinner speed must be calibrated to spread material in a pattern of a particular width. There are four trim settings for the spinner that cannot be set automatically: a one and three lane wide pattern for “normal” dispensing rates as well as one and three lane wide settings for “blast” dispensing rates. **To trim these settings accurately, the unit must be filled with material to set spread widths and the truck must be running at normal operating RPM’s. Too low RPM’s will result in inconsistent spinner performance.**

**Detailed trimming instructions for zero velocity spinner are listed in “detailed spinner trims.”**

1) Enter configuration menu by simultaneously hold the auger and pre-wet switches down to enter the “configuration screen.” You will be asked for a password, enter “\_\_\_\_\_” using the spinner controls to change the digits, and the blast/pass (pause) controls to change cursor positions. Run the cursor past the end of the password to enter setup mode.

**Set the One Lane Spinner speed:**

- 2) Select trim/cal. Select spinner trim.
- a. Select the “one lane wide” trim setting and follow the on screen instructions.
  - b. Increase the auger setting until a small amount of granular material is being augured off the truck.
  - c. Increase the spinner setting until a one lane wide (12 feet wide - measured) pattern is being thrown.
  - d. Press pass (pause) to accept the one lane speed setting.

**Three lane Spinner:** Follow the same procedure for setting 3 lanes wide (36 foot) pattern.

**Set the blast spinner settings (allows “blast setting on the auger to be spread uniformly in a width between 1 lane and 3 lanes).**

- 1) Use the spinner key to go down to the “one lane blast” trim setting.
- 2) Set the auger to dispense the amount of material dispensed while in blast mode.
- 3) Increase spinner speed to create a “one lane wide” pattern.
- 4) Press “pass (pause)” to accept the “one lane blast” setting.
- 5) Follow the same procedure for three-lane blast trim calibration.
- 6) Once the one and three lane trim for both normal and blast amounts have been set, the spinner is calibrated.

## **STEP C - Post Delivery Functional Test**

In Non-Speedo mode verify system functions and is stable at the ground speed and delivery rates the customer expects.

For trouble shooting ideas, see the trouble shooting section of this manual or the diagnostics screen in the SpreadSmart Rx mode screen.

**Note: it is recommended that you save all settings after completion of all system setup and calibration to a PC for safekeeping. In the event of loss of this setting information, it can be uploaded from the stored file in a matter of minutes.** Storing this information is described in the section of the manual “Other Downloads.

## **Managing Materials – Granular, Pre-Wet and Anti-Ice**

For maximum flexibility of operation, *SpreadSmart Rx*<sup>TM</sup> allows you to define operating programs by using the “Name” to designate either a different material (salt/sand; Brine/KCl, etc); or to designate a different material distribution rate (Salt 500, Salt 1000, etc); or to use several of each within the 10 choices/material the system offers. The word “material” is used for consistency even though you are allowed to name either a “unique material” (salt or sand) or a unique set of distribution conditions for the same actual material (salt, salt 500, salt abc, etc.).

To enter the materials screen:

- 1) Power up the unit, when the “mode” screen is displayed, simultaneously hold the auger and pre-wet switches down to enter the “configuration screen.” You will be asked for a password, enter “\_\_\_\_\_” using the spinner controls to change the digits, and the blast/pass (pause) controls to change cursor positions. Run the cursor past the end of the

- password to enter “Configuration screen”. Changing settings without authorization can result in performance variations; password should only be given to authorized personnel.
- 2) Move the arrow to “materials” and select “pass (pause)” to enter the materials screen.

Configuration	
Setup Wizard	Advanced
System Setup	Set Clock
Trim/Cal	Reset All
→ Materials	Save and Exit
<BLAST>=done    <SPIN+/->=sel    <PASS>=next	

Choose the material you wish to define your settings for (granular, pre-wet or anti-ice) and make the following four settings for each individual “material” you wish to “name.”

- 1) Name: Up to 10 granular programs, 10 pre-wet programs and 10 anti-ice programs) can be defined (each named with up to 8 characters). In normal operation, the operator selects his material from those defined on this list. The “name” is used to identify the ten different material types or distribution settings. Ex: “Salt” is often used generically and doesn’t have a pre-programmed distribution rate. The operator is then free to adjust his distribution rate using the Auger switch. “Salt 500” is a pre-programmed setting that could deliver 500 lbs / lane mile of salt. In that case, the operator cannot change the rate without changing material type. This also apply for pre-wet and anti-ice.
- 2) Min and Max Rate settings for each material: These are the lowest and highest settings the operator can select while in automatic mode, in pounds per lane mile. The system allows the minimum to be set at 0 and the max at 9999. In typical applications, minimum is usually set no lower than 100 lbs and maximum not above 3,000 lbs. To “pre-program” a specific rate, set the min and max at the same value (eg. 500lbs/lane mile), thereby “locking” the rate only at that value for that material.
- 3) Blast mode setting: is the number of pounds per lane mile that are dispensed when the truck is in blast mode (automatic mode only).
- 4) Small and large rate change increment settings: are the amount that the dispensed rates are changed when the rate switch is pressed, and how much the rates are changed when the rate switch is pressed and held.

### Choosing a material name and recording data:

*SpreadSmart Rx*<sup>TM</sup> records all spreading output for each uniquely named material. The Spreading Performance Report uses this information to produce combined material reports and individual reports for each named material. To ensure integrity in the combined materials reports, material names are limited to 8 characters and must follow this convention:

Material Name must be consistent: **all materials named Salt with a space following the “t” will add correctly** together in the following example.

- e. Salt
- f. Salt 500
- g. Salt 1000

Inconsistent Material Names will not add together correctly

- h. Salt500
- i. Salt 1000
- j. Salt Special

**Note: This naming convention affects the combined material reports and if not followed consistently, will make the summary reports inaccurate.**



## Changing “Materials” program during normal operation

Once your materials set up is complete, an operator can select any programmed choice by selecting “materials change” from the main “mode” screen before the system drops into automatic operation mode. From there, the operator can choose any of the programmed material types designated in the prior section.

## Temp Response™ Prescription Set Up – for each material type

For any material type, you can also create up to four Temp Response™ prescriptions to automatically change spreading rates as a function of road temperature. The user, for their local conditions, determines the actual temperature/spreading rate relationship. Temp Response™ prescriptions can be run for one material (salt) or for combinations (salt and pre-wet), but each is configured individually. English or Metric units are shown based on the system setup choice.

To set a temperature controlled, granular spreading prescription, enter configuration menu by simultaneously holding the auger and pre-wet switches down to enter the “configuration screen.” Enter your password using the spinner controls to change the digits, and the blast/pass (pause) controls to change cursor positions. Run the cursor past the end of the password to enter setup mode.

Configuration		Setup	
Setup Wizard	Advanced	→ 1) SALT	6)
System Setup	Set Clock	2)	7)
Trim/Cal	Reset All	3)	8)
→ Materials	Save and Exit	4)	9)
		5)	10)
<BLAST>=done <SPIN+/->=sel <PASS>=next		<BLAST>=done <SPIN+/->=sel <PASS>=next	

Scroll down to Prescription, Use “Anti-Ice” paddle to select Prescription RX1- RX4. Incomplete prescriptions are listed as “undefined.” Up to four prescriptions are can be created for each media type (Granular = 4; Pre-Wet =4; Anti-Ice = 4).

Granular Material (Page 1/2)		Granular Material (Page 1/2)	
→ Name: [SALT ]		Name: [SALT ]	
Min. Rate: 0/MILE		Min. Rate: RX1/MILE	
Max. Rate: 900/MILE		Max. Rate: RX1/MILE	
Blast Rate: 1200/MILE		Blast Rate: 1200/MILE	
Prescription: OFF		→ Prescription: RX1 !Not Defined!	
<SPIN+/->=sel <ICE+/->=adj <BLAST>=done		<SPIN+/->=sel <ICE+/->=adj <BLAST>=done	

Change the Prescription from off to Rx1 and hit pass (pause) to enter values for prescription RX1:

Temp Prescription Granular 1		Temp Prescription Granular 1	
→ High Temp: 0°	Rate: 0	→ High Temp: 35°	Rate: 200
Medium Temp: 0°	Rate: 0	Medium Temp: 32°	Rate: 300
M. Low Temp: 0°	Rate: 0	M. Low Temp: 29°	Rate: 350
Low Temp: 0°	Rate: 0	Low Temp: 25°	Rate: 400
	Rate: 0		Rate: 500
<SPIN+/->=sel <ICE+/->=adj <BLAST>=done		<SPIN+/->=sel <ICE+/->=adj <BLAST>=done	

In this example, the prescription has been set as follows:

Temperature Range (F)	Salt Spread Rate
Above 35 degrees	200 (lbs/mile)
34-32 degrees	300 (lbs/mile)
31-29 degrees	350 (lbs/mile)
28-25 degrees	400 (lbs/mile)
Below 25 degrees	500 (lbs/mile)

(Note: these rates are for illustration only and are not process recommendations).

Select “blast” and return to the Granular material screen to confirm prescription is set:

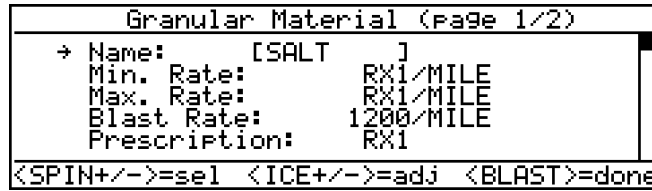

Your prescription for your granular material named “salt” is now set. To set another granular material, choose name #2-10, select Prescription RX2-4 and repeat the process. When operating the SpreadSmart Rx or RDS, the letters **Rx** is added to the display to show that *Temp Response*™ is controlling the granular and pre-wet spreading rate.

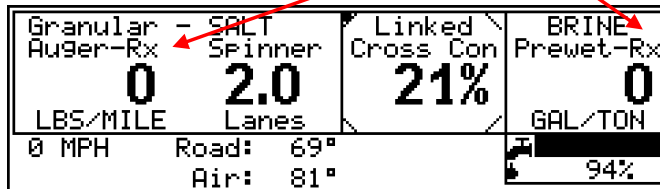

**For Pre-Wet or Anti-Ice prescription setting**, choose one of those “materials” and begin the naming and prescription setting process as above. Because the distribution rate varies with material, a prescription must be set individually for each.

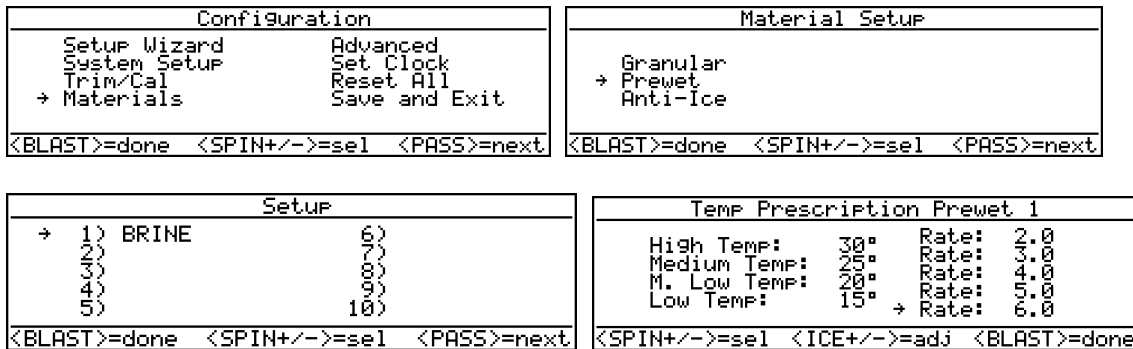

In this example, the prescription has been set as follows:

Temperature Range (F)	Liquid Rate
Above 30 degrees	2.0 (gal/ton)
29-25 degrees	3.0 (gal/ton)
24-20 degrees	4.0 (gal/ton)
19-15 degrees	5.0 (gal/ton)
Below 15 degrees	6.0 (gal/ton)

(note: these rates are for illustration only and are not process recommendations).

#### Recording Spreading Data for each named material

Data recording for each named material occurs whenever that material name has been selected and material is spread in automatic operating mode. No action is necessary to begin the recording of spreading data for each named material.

Operating Mode	Spreading Data Recording
Automatic	yes

No Speedo Mode	yes
Manual Mode	no
Test Mode	no

## Using Preset Rates with Materials

Up to 10 preset rates can be defined for each granular, pre-wet, and anti-ice material. One advantage of preset rates is the use of non uniform intervals between rates. To turn this feature on, set the “Enable Preset Mat. Rates” to Yes in System Setup. Enabling the preset material rates requires that the granular, pre-wet, and anti-ice materials being used must have their rates predefined, and no longer use the min/max increment to adjust rates in modes.

**To define preset rates for materials**, enter the configuration menu by simultaneously holding the auger and pre-wet switches down to enter the “configuration screen.” Enter your password using the spinner controls to change the digits, and the blast/pass (pause) controls to change cursor positions. Run the cursor past the end of the password to enter setup mode.

Configuration		Setup	
Setup Wizard	Advanced	→ 1) SALT	6)
System Setup	Set Clock	2)	7)
Trim/Cal	Reset All	3)	8)
→ Materials	Save and Exit	4)	9)
		5)	10)
<BLAST>=done <SPIN+/->=sel <PASS>=next		<BLAST>=done <SPIN+/->=sel <PASS>=next	

Select the number of rates being used for this material (Preset Rate Cnt). Scroll to “Show Preset Rates ->” and use pass (pause) to view the preset rates.

Granular Material page 2/2		Granular Material page 2/2	
Large Increment: 50 LBS/MILE		Large Increment: 50 LBS/MILE	
Show Preset Rates ->		→ Show Preset Rates ->	
→ Preset Rate Cnt: 4		Preset Rate Cnt: 4	
Pulses/LB: 145.0		Pulses/LB: 145.0	
Maximum LB/min: 2000		Maximum LB/min: 2000	
<SPIN+/->=sel <ICE+/->=adj <BLAST>=done		<SPIN+/->=sel <ICE+/->=adj <BLAST>=done	

Enter the rates starting with rate 1 through the preset rate count from the previous step.

Preset Rates Granular: SALT			
→ Rate 1:	0	Rate 6:	0
Rate 2:	200	Rate 7:	0
Rate 3:	400	Rate 8:	0
Rate 4:	600	Rate 9:	0
Rate 5:	0	Rate 10:	0
<SPIN+/->=sel <ICE+/->=adj <BLAST>=done			

## Managing Information on SpreadSmart Rx™

Four groups of information are “stored in” or “recorded by” *SpreadSmart Rx™*

**Trims and Calibration of Spreader Hardware:** these settings are chosen after installation in a truck and are the coordinated result of the interaction between the *SpreadSmart Rx™* and the hydraulics system it is paired with. This data is stored on the *SpreadSmart Rx™* CPU and is download-able and upload-able using the *SpreadSmart Rx™* connected to a Laptop PC.

**System Set Up (Operating Parameters):** these settings are selected by the installer, the site supervisor or (in some cases) by the operator and determine the manner in which the *SpreadSmart Rx*<sup>TM</sup> operates. This data is stored on the *SpreadSmart Rx*<sup>TM</sup> CPU and is download-able and upload-able using the *SpreadSmart Rx*<sup>TM</sup> serial port connected to a Laptop PC. (Note: 1 & 2 are stored, uploaded or downloaded as a single file).

**Storm and Season Totals:** this function records the amount of material distributed for each named material. This data is recorded on the CPU and is downloadable via serial connection to a laptop PC.

**Spreading Performance Report:** this data is the record of performance and events that occurred during actual spreading. *SpreadSmart Rx*<sup>TM</sup> records this continuously and then stores it on the MMC bulk data storage card at a settable rate. MMC stored data is download-able using the *SpreadSmart Rx*<sup>TM</sup> wired or wireless data transfer options (see optional equipment).

The table below indicates types of data stored and used by *SpreadSmart Rx*<sup>TM</sup>

Information	Description	Information Movement Direction	SpreadSmart Rx	Common Usage
Trims, Settings	Hydraulic Settings	Upload----- Download-----	Laptop PC Serial Laptop PC Serial	Same settings for multiple trucks;
System Set Up	Chosen operating parameters	Upload----- Download-----	Laptop PC Serial Laptop PC Serial	Re-install settings after repair;
Storm/Season Totals	Spreading totals stored by storm or season only	Upload----- Download-----	None; Laptop PC Serial,	Normal log for recording spreading results
Spreading Performance Report	All record-able data that the spreader tracks.	Upload----- Download-----	None; MMC Card, RJ45, Serial or Wireless <i>Drive By Download</i> <sup>TM</sup>	High volume data for events, alarms, GPS, etc.

## Battery Backup for Date and Time

*SpreadSmart*<sup>TM</sup> includes a 3 volt battery to store data in RAM when the truck power is off. Backup batteries are designed to last up to 5 years in normal usage, but may wear out before that time. Data in RAM storage includes:

Date and Time: this information is critical when recording spreading data;

“Last Used” Settings: *SpreadSmart* stores the last settings in use when the truck is turned off and restores them using the backup battery when the truck is restarted. These settings include auger, spinner, pre-wet and anti-ice rates currently in use;

LCD Contrast settings: if the contrast has been changed from the default settings, the backup battery stores the current setting.

Storm and season totals: spreading data only.

Liquid tank levels: the graphical display only.

**Indication that the battery needs to be replaced:** a lowercase “b” will show up on the top left of the system menu screen when the battery is exhausted. Additionally, items a-e above will revert to “default values” if the battery needs to be replaced.

**Battery Replacement:** the battery is inside the red CPU. Disconnect power; open the case and battery can be physically removed. This operation should be performed by someone comfortable with working on electronics, as care should be taken to avoid static discharge. The battery is most easily removed using a pair of small pliers. The new battery can be slid into the socket without the use of tools, but confirm that the battery clip holds the new battery tightly.

### Part availability

Any battery which cross references to the BR2020 number or the CR2450 number can be used as a suitable alternative. Please verify the physical dimensions and the 3V rating before inserting the new battery in the spreader. Batteries can be found at most battery stores, and various electronic stores (such as Radio Shack).

## Accessing Storm and Season Totals (SST) from *SpreadSmart Rx*™

Choose the Storm and Season Totals from the menu screen:

Menu v6.19 Rx		Storm and Season Totals	
Automatic Mode	→ Load/Rate Calc.	→ Storm Totals	
Manual Mode	Test Mode	Season Totals	
No Speedo Mode	Material Change		
Unload Mode	Fill Tanks		
Storm/Season Tot.	Diagnostics		
<SPINNER +/->=select <PASS>=accept		<BLAST>=done <SPIN+/->=sel <PASS>=next	

View total and average miles recorded any time the SS Rx is powered on and vehicle is in motion (does not need to be spreading).

Storm Totals page 1/5	
Total miles:	0.2
Average MPH:	10.2
<BLAST>=done <SPIN+>=prev <SPIN->=next	

View amount spread by named material, miles driven, hours operated, during spreading of that material and average amount per mile driven.

Storm Totals page 2/5		Storm Totals page 3/5	
SALT miles:	0.2	BRINE miles:	0.2
SALT hours:	0.0	BRINE hours:	0.0
SALT lb:	0	BRINE gallons:	0
Average LB/MI:	0.0	Average GAL/TON:	0.0
<BLAST>=done <SPIN+>=prev <SPIN->=next		<BLAST>=done <SPIN+>=prev <SPIN->=next	

Note: all SST totals may be re-set by the operator and are only accurate since the last re-set. Automatic mode spreading data used by *Drive by Download*™ is not re-settable, but cannot be viewed from the SST screens.

## Downloading Storm and Season Totals (SST) from *SpreadSmart Rx*™

From time to time in the course of normal operation, the administrator will download the spreading data collected by the *SpreadSmart Rx*™. This downloading process is accomplished using standard equipment or optional equipment (described in optional equipment section). The method for standard equipment is as follows:

Hardware Required:

Laptop computer with Windows 2000 or XP operating system;

Cirus Controls “Storm and Season Totals (SST) Utility” for Windows (CDROM);

Standard PC serial cable (male to female DB-9 terminations) or USB to serial” conversion cable;

Download Steps

Power *SpreadSmart Rx*™ off and connect PC using serial cable;

Rev AG

Page 25

4/7/2016

Copyright © 2014 by Cirus Controls, LLC. All Rights Reserved. No part of this material may be reproduced without the express written permission of Cirus Controls LLC for each reproduction.

Open SST Download utility on PC;

The SST will report “waiting for connection” in the red bar. If the COM port does not open, SST will report the error in the red bar. To correct error, turn off any device using COM port. Re-start SST Download utility and verify that PC is “waiting for a connection.”

Power *SpreadSmart Rx*™ on to automatically initiate download. SST will display the resulting data. You may print or save the data by selecting “print” or “save”.

If you choose to save the data, it is stored on your PC as a standard “comma delimited text file (xxx.csv)” that can be opened later by various PC applications.

## **Re-Setting Totals (SST) on *SpreadSmart Rx*™**

Typical use of these recording functions is to use one to record short time duration spreading data (shift, day, or storm totals) and the other to record longer time duration events (season totals). “Storm totals” can be re-set by the operator in the truck, “Season” totals are only re-settable by an administrator with a password. Note: once either or both of the totals are re-set in *SpreadSmart Rx*™, they are no longer retained in memory. Be sure to complete your data download before re-setting either or both of these totals.

### **Re-Setting Storm Totals:**

Return to Mode screen (turn power off and on) and use spinner to arrow to “storm and season totals.” Select by choosing “pass (pause).”

Use “pass (pause)” to select **Storm** totals;

Use “spinner” to scroll to last page - “press pass (pause) to clear storm totals” and select “pass (pause)”.

*SpreadSmart Rx*™ will ask you to confirm that you wish to delete totals. Use “spinner” to select “y” and press pass (pause) to complete re-setting of storm totals.

Re-setting is complete and *SpreadSmart Rx*™ automatically returns you to the mode screen and normal operation.

### **Re-Setting Season Totals:**

Return to Mode screen (turn power off and on) and use spinner to move arrow to “storm and season totals.” Select by choosing “pass (pause).”

Use “spinner” to move down and “pass (pause)” to select **Season** totals;

Use “spinner” to scroll to page saying “press pass to clear season totals” & select “pass (pause)”.

*SpreadSmart Rx*™ will ask you to confirm that you wish to delete totals. Use “spinner” to select “y” and press pass (pause) to move to password for final approval.

Enter \_\_\_\_\_ and hit “pass (pause)” to complete re-set of season totals.

Re-setting is complete and *SpreadSmart Rx*™ automatically returns you to the mode screen and normal operation.

## **Other Downloads – Calibration/System Settings Data**

These settings discussed here are described in the System set up section of the manual. Some users choose to store those settings by downloading them to a PC for use in the event of a desire to use them in multiple trucks or to allow a fast re-set of a controller that has been repaired.

### **To download these settings and store them:**

a) Plug the standard male to female serial PC cable from your computer to the system serial port: located on the side of the backpack case. If your PC has a USB connection and not a serial port, insert a USB to Serial adaptor (Belkin FSU 409 or equivalent) between your PC and the serial connection.

b) Start the SPRDUTIL.EXE utility. The utility will report “waiting for connection” in the red bar. If the COM port does not open, SPRDUTIL will report the error in the red bar. To correct

- error, check Com port number setting on SPRDUTIL Utility and make sure that no device on your PC is using that same number COM port (such as a Palm Pilot etc). Turn off any device using COM port. Re-start SPRDUTIL utility and verify that PC is “waiting for a connection.”
- c) Cycle the power on the spreader system. Both the TX and RX lights on the application should blink momentarily, and the bar should go from red to green, and indicate "SpreadSmart Rx (or Stingray) PC Interface". The "Retrieve Calibration" button should now be selectable.
- d) Press the “Retrieve Calibration" button on SPRDUTIL.EXE, and when the “Save As” dialog box appears, name the file and choose the location you wish to save it to on your PC. Then select “save.” The download is very quick and the progress bar is not used. Verify that the file has been saved in the location you chose.
- e) When you have verified the location of the file, close the SPRDUTIL.EXE by clicking on the x in the corner.

**To Upload (Restore or Send) Calibration/Settings Data:** follow the above instructions through (c) and then:

- d) Press the “Send Calibration" button on SPRDUTIL.EXE, the file is automatically transferred to the *SpreadSmart Rx™*.
- e) Power down and up on the *SpreadSmart Rx™*. A correctly transferred calibration file will allow you to run in Automatic mode (no line through it). No other indication shows a completed transaction.

## ***Operational Modes - Description***

### **Accessing the “Mode” Screens**

The primary choice screen is called the “mode” screen. From this screen, the operator can access all normal operating modes, all testing modes, all help screens, all system setup screens and all material change screens. The mode screen appears as the second screen (after the logo/copyright screen) after powering the system up. The mode screen can be accessed from other screens by: During normal operation, by pressing the “AUX (MENU)” switch. During normal operation, by “powering down” the *SpreadSmart Rx™*, followed by “power up”. During setup and configuration, by pushing “blast” until you have returned to the mode screen.

### **Automatic Mode – Ground speed oriented**

Automatic mode is the normal operating mode of *SpreadSmart Rx™*. In automatic mode, the *SpreadSmart Rx™* tracks ground speed and then adjusts output rates based on that speed so the amount of pounds per lane mile of material dispensed is consistent regardless of speed. To enter automatic mode, turn unit on and select Automatic from the menu or allow the system to default into Automatic mode after ten seconds. To dispense material in this mode, the truck must be moving.

In automatic mode, the granular amount dispensed is displayed in pounds per lane mile or pounds per mile. Pressing the auger +/- switch once will show the set amount, pressing it again will change the set amount. After three seconds, the measured rate will be displayed again.

The spinner control is shown in number of lanes wide. If the pre-wet on/off switch is set to on, the pre-wet pump is turned on and dispensed rate is shown in gallons per ton. The bar graph on the right side of the screen shows the liquid tank level.

## Alarms

In automatic mode, the sensors are used to determine how much material is being dispensed. Without these inputs, the *SpreadSmart Rx™* can't accurately measure the amount being dispensed. The *SpreadSmart Rx™* system uses the auger sensor to measure granular material dispensed, the pre-wet (and/or) the anti-ice flow meter to measure liquid dispensed.

**Auger Sensor Fail:** If the system detects an auger sensor failure, it indicates either a stopped auger or a bad sensor signal. The system will beep and display “auger sensor fail” in a flashing sequence on the screen. Simply pressing the auger +/- switch will silence the alarm, and the unit will drop into “open loop auger” mode and continue running. This allows the operator to verify his operation and (if only the sensor has failed), he may continue to distribute granular material until repairs can be made.

**Pre-Wet Flow Meter Fail:** If the system detects a pre-wet flow meter failure, it indicates that either the sensor failed or the pump can no longer function safely, because the tank is empty. To prevent burning the pump up, *SpreadSmart Rx™* automatically shuts the pump off and raises an alarm. To silence the alarm, simply toggle the pre-wet (-) switch or turn “off” the pre-wet “on/off” switch. If the system has been set up to allow flow sensor alarm overrides (see Dry Run in set up), you must press and hold pass (pause) then press the pre-wet (+) switch, at which point the system functions in open loop pre-wet mode.

**Anti-Ice Flow Meter Fail:** If the system detects an Anti-Ice flow meter failure, it indicates that either the sensor failed or the pump is no longer functioning safely, because the tank is empty. To prevent burning the pump up, *SpreadSmart Rx™* automatically shuts the pump off and raises an alarm. To silence the alarm, simply toggle the Anti-Ice (-) switch or shut off the Anti-Ice “on/off” switch. If the system has been set up to allow flow sensor overrides, you must press and hold pass (pause) then press the Anti-Ice (+) switch, causing the system to be in open loop.

**Off Rate Alarm:** in the case of closed loop systems, *SpreadSmart Rx™* can detect (by measuring return pulses), how accurately it is achieving the programmed output rate of granular, pre-wet or anti-ice material. If factors (jamming, lack of hydraulic power, other) prevent the planned output from occurring, the Off -Rate alarm will be displayed for the system not meeting its programmed rate (granular, pre-wet or anti-ice).

### Maximum Speed Alarm

As part of the system setup, an alarm can be set when the vehicle exceeds a chosen speed. The system will beep and flash the speed reading on the screen. The alarm stops when vehicle speed is reduced below the programmed speed maximum.

## Manual Mode – Ground speed triggered

Manual mode allows the operator to adjust his output settings as a % of output capacity without a calibrated “pounds/mile” setting. In manual mode, output rates are displayed as a percentage of full-scale output and are ground speed triggered (meaning they turn on to the set rate when the truck starts moving, and stop with the truck). A proper ground speed signal is necessary to allow operation in manual mode. If no ground speed signal can be established, convert to “no speedometer” mode or to “test” mode.

Manual mode is the default-operating mode before the system has been trimmed. It allows manual dispensing of material with a minimum amount of system set up. You select manual mode from the mode screen by scrolling the arrow to “manual” and pushing “pass (pause)”.

## No data logging occurs in manual operation mode.



## No Speedometer Mode – Ground speed simulated

This mode is the backup-operating mode for SpreadSmart Rx in the event that the speedometer sensor fails and the driver wishes to continue to dispense material prior to repair. In a trimmed truck, select “no speedometer mode from the mode menu” and the output rates will be displayed in pounds per lane mile and gallons per ton, (as in automatic mode). If the unit is not trimmed, rates will be displayed in percent of full scale and operation will be open loop, as in manual mode. Refer to the following table for details about “no speedometer”-operating mode:

	Truck trimmed and Auto mode selected	Truck not trimmed or auto mode not selected
<b>Granular Material Units</b>	Pounds per lane mile	Percent of full scale
<b>Spinner Units</b>	Lanes	Percent of full scale
<b>Pre-wet Units</b>	Gallons per ton	Percent of full scale
<b>Operating Mode</b>	Closed loop, ground speed oriented	Open loop, ground speed triggered
<b>Speed</b>	MPH, adjusted while in pass (pause) mode using the auger +/- switches <sup>1</sup>	Moving or stopped, using the pass (pause) switch <sup>2</sup>

<sup>1</sup> Driver can set desired simulated speed. Press pass (pause) and use the auger up and down key to change the speed do this. **Once the desired speed is set, the pass (pause) switch must be pressed again to start dispensing.**

<sup>2</sup> Driver tells the unit whether the truck is moving or stopped using the pass (pause) switch.

## Testing the Boom Tiers using No Speedometer Mode

No Speedometer mode can be used to test the flow rates of each boom and of each tier in a stationary truck. *SpreadSmart Rx* <sup>TM</sup> automatically determines which boom tier runs based upon the rating of the booms (in GPM), the calibration settings in the system, on the speed the truck runs and on the flow rate (in GPL-M) selected by the operator. No Speedo Mode can be used to simulate truck speed in a non-moving truck to allow you to verify that each boom tier turns on and off at the planned flow rate.

To make the determination, verify the flow ratings of your boom tiers and using the chart above to select several combinations of flow rates and speeds which are just above or just below the rates where the flow ratings of the tiers overlap. For example in a truck with tiers rated at a maximum of 8GPM for the low flow tier and 48 GPM for the high flow, we suggest you select speed and flow rate combinations that allow you to test for flows at 7, 9, 47 & 49 GPM (one gallon above and below the max rating of each tier).

To use “No Speedo” mode to simulate the speed / flow rate combinations for above: Menu switch on, automatic on, all boom switches off. Pass (pause) to select “No Speedo”; Display should show the current flow rate in GPL-M, should show that none of the boom switches are highlights (in off position), should show the default liquid material selected, and at the bottom of the screen should show 0 mph.

Select “pass (pause)”, screen will respond with the word <pass> in brackets. Use the anti-ice toggle to increase the mph to the desired speed. Hit “pass (pause)” again to begin the simulated movement. <pass> will disappear from the screen.

Use the anti-ice toggle to increase or decrease the rate of liquid delivery (in GPL-M).

Verify that there is liquid in the anti-ice tank and that dispensed liquid will not cause problems.

Open one or more boom valves by turning on the corresponding boom switch.

Continue the test at each of the planned combinations of speed and flow rate settings to determine if correct boom tier operates as planned.

Turn off boom switches to complete the test and return system to auto mode by turning menu switch off and automatic switch on.

## **Test Mode – No ground speed interaction**

The technician, when verifying hydraulic valve outputs and sensor inputs, normally uses this mode. All output rates are displayed in percent of full scale and sensor inputs are displayed in pulses per minute. With the pre-wet switch on, the pre-wet output level and pre-wet sensor are displayed; with the pre-wet sensor off, the speedometer sensor signal is displayed.

Test mode may be used as an operating mode when a “no ground speed interaction” mode is desired (aka: completely manual operation). Material output is not related to truck motion or speed and is controlled only by the settings for the auger/conveyor, spinner, pre-wet, and anti-ice.

## **Unload Mode – Granular or Anti-Ice**

This mode is used for unloading the truck and computer simulates motion to allow the over-ride of the safety feature that prevents material from pumping unless the truck is moving and boom switches are on. Note: verify proper valve settings for system before operating unload mode. All three media (if they are enabled) are displayed on the Unload Mode Screen, however, no dispensing can occur unless the on/off switch is “on” and the % output is raised above “0%”. Material can be unloaded individually or simultaneously if you choose. Note: Pre-Wet Material is normally not unloaded using the SpreadSmart Rx controller. Most systems are plumbed with a manual unload valve/spigot.

### **Granular Material**

Power down and then up, scroll down to Unload Mode and push “pass (pause)” to select; Verify that the media you wish to unload (granular) is on using the main switch. The unload mode operating screen is displayed and the rate defaults to 0% (The rate is displayed as a percentage of full scale).

Raise the % output to the desired level using the auger +/- toggle.

Pressing pass (pause) in unload mode turns off dispensing.

When unloading is complete, push blast and controller will return to the mode screen.

### **Anti-Ice Material**

Turn off boom valves on *SpreadSmart Rx*<sup>TM</sup>.

Power down and up, scroll down to Unload Mode and push “pass (pause)” to select; The unload mode operating screen is displayed and the rate defaults to 0% (The rate is displayed as a percentage of full scale).

Actuate one or more boom switches.

Raise the % output to the desired level using the anti-ice +/- toggle.

(The truck must be stopped in order to pump liquid material. Dispensing will stop when the truck is moved, and will automatically resume when the truck stops again.)

Pressing pass (pause) in unload mode turns off dispensing.

When unloading is complete, push blast and controller will return to the mode screen.

## **Using Unload Mode to Re-circulate the material in the anti-ice tanks**

Verify that the anti-ice system is plumbed with a re-circulation return line; truck must be stationary for pump to operate. If re-circulation line is not present, pump will be damaged if operated in this mode. Note: verify proper valve settings for your system before operating in unload mode.

Turn off all boom valves on *SpreadSmart Rx*<sup>TM</sup>.

Turn on menu switch, scroll down to Unload Mode and push “pass (pause)” to select; The unload mode operating screen is displayed and the rate defaults to 0%. Raise the dispensing rate to 25% using the anti-ice +/- toggle and pump will circulate material from the tank through re-circulation return line back into the tank. Note: leave boom valve switches off or material will be dispensed. Turn off menu switch when unloading is complete and truck will return to automatic.

## Contrast

The contrast for the display is set at the factory for average brightness. Contrast can be adjusted for personal preference and individual lighting. To adjust, push the auger and pre-wet paddles up simultaneously, use the spinner up and down key to adjust the contrast to a readable level, and press pass (pause) to accept. This setting will be remembered between power downs until the next time contrast is set.

## Speedometer with Re-settable Odometer (miles & feet)

*SpreadSmart Rx*<sup>TM</sup> uses the calibrated link to the truck speedometer to display a single mile odometer in the diagnostics section of the menu screen. This odometer displays in feet and portions of a mile, can be re-set by selecting pass (pause) = zero and re-sets automatically when it reaches 5,280 feet. This function is used for road distance measurements and its accuracy is a function of the accuracy of the truck speedometer and the calibration.

Diagnostics		Diagnostics	
Firmware versions	Automatic Mode	Speed:	0 MPH
MMC/SD Data Card	MDM Module	Distance:	0.0 Miles <PASS>=zero
GPS Antenna	→ Speedometer		0 Feet
RoadWatch			
<BLAST>=done <SPIN+/->=sel <PASS>=next		<BLAST>=done	

## Material

If more than one material has been pre-defined in the material calibration setting section, the material can be changed here. This allows for multiple weight calibrations, minimum and maximum dispense settings, and varying blast rates.

## Fill Tank

On a pre-wet-equipped system, the *SpreadSmart Rx*<sup>TM</sup> maintains the tank level by calculating the amount dispensed. When the tank is filled, the level in the *SpreadSmart Rx*<sup>TM</sup> unit must be updated to reflect this. By simply pressing pre-wet (+) the tank level is re-set to “full”. Should you choose to partially fill the tank, you can estimate the displayed percentage by pressing the pre-wet rate switch (up or down) to change the tank level to estimate a partial fill. Correctly setting this feature enables the low level warning system (which functions in open or closed loop set ups), but does not affect the automatic pump protection system. Automatic pump protection is only possible in closed loop systems which give flow sensor readings to the controller.

## Common Methods of Operation in Automatic Mode

### Using Named Materials with Flexible Rates:

A common operating mode is to name the material(s) being distributed, but not to pre-determine the rate at which the material will be distributed. This allows the operator to use the *SpreadSmart Rx*<sup>TM</sup> switch panel to respond to changing conditions by adjusting the material distribution. Following the instructions in the “managing materials” section of the manual will

allow you to designate the material name, the full range of rate applications allowed (min and max) and the increment at which the rate can be changed using the switch panel.

### **Using Named Materials/Rates with no changes allowed:**

Many sites choose to pre-set the actual rate of material distribution and not allow changes by the operator unless another material name (with a different program) is chosen. This method defines the particular amount of material (lbs/lane mile) that will be distributed during the run. The actual rates will vary by location and type of material being spread. Following the instructions in the “managing materials” section of the manual, allows you to set the minimum rate of distribution equal to the maximum rate of distribution, thereby allowing “no changes” to the settings you have chosen. The rate change switches on the SpreadSmart Rx™ will not change the material distribution setting once the “pre-programmed material name” is selected in automatic mode.

### **Using Named Materials with Programmed Rate Change Increments:**

This method of operation allows the operator to change rates of distribution during the course of a run, but only within the limits (min and max rate) and at the increments (100 lbs, 250 lbs, etc) that is designated. This method gives the operator some discretion at setting his distribution, but only within planned limits. Following the instructions in the “managing materials” section of the manual, allows you to set the min. and max. rates of distribution as well as the rate change increments to create the range of operating limits you wish to achieve.

## **Load and Rate Calculation**

*SpreadSmart Rx*™ allows operator to calculate, properly load liquid and granular materials on spreading vehicles and set the liquid and granular rate(s) to accomplish the following process parameters:

**Fully consume the maximum amount of pre-wet salt brine capacity on a vehicle** for a given length of route (fill the pre-wet liquid tanks full and consume all of it for a particular route).

**Allow the use of Anti-icing tanks (on board or pulled with trailer) for simultaneous use with granular and pre-wet systems and fully consume the loaded liquid.**

Using the amount of salt brine available on a fully loaded truck, **calculate the amount of dry granular salt material to load onto that truck to deliver a particular total amount of salt** for the planned route (**Total salt pounds for route = liquid salt + granular salt**). **Load**

**Calculation is increased by 10% for excess granular;**

**Operational Description of Rate and Load Function –**

**To begin: access the menu screen to select Rate and Load calculation screen:**

System set up requirements:

*SpreadSmart Rx*™ must have pre-wet and anti-ice set up in gallons per mile. Rate and load calculator does not work when pre-wet is set to run in gallons/ton of granular material.

*SpreadSmart Rx*™ must be setup with the correct materials chosen for the application. In the case of salt and brine spreading, the granular material must be set for salt and the pre-wet material for brine (materials screen); If the correct material names are not chosen, then accuracy of downloaded data can be compromised.

Tank volumes shown in *SpreadSmart Rx*™ setup menus must be accurate for both pre-wet and anti-ice. The bar graph and % remaining displays are driven using the tank volumes in the set up menu and not those from the rate calculator;

**Select Menu Screen and move cursor to select Route/Rate Calculator –** note that the help screen menu choice has been moved inside the Diagnostics screen menu choice;

Menu		v6.19 Rx			
Automatic Mode	→ Load/Rate Calc.	Inputs:	Calculations:		
Manual Mode	Test Mode	Route Miles	11	Salt Tons	0.8
No Speedo Mode	Material Change	App. Rate	250	Auger Rate	140
Unload Mode	Fill Tanks	Prewet Gal	150	Prewet Rate	12.9
Storm/Season Tot.	Diagnostics	Anti-Ice Gal	425	Anti-Ice Rate	36
<SPINNER +/->=select		<PASS>=accept		<BLAST>=cancel	

**Input Values – for this rouPre-Wet (Gal/Liters)** = amount of pre-wet liquid loaded on this truck for this route;

This amount will be the basis of the gallons and % remaining display:

**Complete fill** - the maximum gallons (liters) the truck will hold – (system will not accept a larger value than maximum shown on set up page)

**Partial Fill** = the number of gallons actually loaded in the tank(s);

**Pre-Wet (gal / ltr.) is adjusted up or down using the Pre-wet +/- toggle.**

Total Pre-Wet fluid capacity is entered during setup on the Pre-Wet setup screen.

When an occasional use device (such as a trailer) is added to the system, the additional fluid volume capacity of the trailer must be added to the “permanent on-board capacity” for a total system capacity shown in the Pre-Wet set up menu.

salt brine rate calculations; 230 lbs salt/100 gal f.

**Anti-Ice Salt (Gal/Liters)** = amount of anti-ice liquid loaded on this truck for this route;

This amount will be the basis of the gallons and % remaining display:

**Complete fill** - the maximum gallons (liters) the truck will hold – (system will not accept a larger value than maximum shown on set up page)

**Partial Fill** = the number of gallons actually loaded in the tank(s);

**Anti-Ice (gal/ltrs) is adjusted up or down using the Anti-Ice +/- toggle.**

Total Anti-Ice fluid capacity is entered during setup on the Anti-Ice setup screen.

When an occasional use device (such as a trailer) is added to the system, the additional fluid volume capacity of the trailer must be added to the “permanent on-board capacity” for a total system capacity shown in the Anti-ice set up menu.

All salt brine rate calculations assume that brine includes 230 lbs salt/100 gal H2O.

**Route Distance:** operator enters miles for planned route using the Spinner +/- toggle.

**Application Rate (lbs. per lane mile)**

Equals the total amount of salt to be spread on this route as defined by the supervisor for the particular storm event;

Value is equal to the pounds of granular salt calculated plus the number of pounds of salt dissolved in the brine in all of the liquid tanks that hold liquid.

App Rate is adjusted using the Auger +/- toggle.

**Operational Calculations made by SpreadSmart Rx™**

**Salt tons** – calculated amount of salt needed to complete the route with 5% overage;

**This value is the basis for the Tons XX.X** shown above the spinner. This amount counts down based on miles driven times the rate per mile;

“Over” shows up instead of a value if the requested amount exceeds the capacity of the dump body/hopper from the granular set up screen.

**Auger Rate:** granular application rate the auger will run at (lbs/mile);

**Pre-Wet Rate** = setting the pre-wet control will run at (use all pre-wet liquid on board for a given route with a 5% liquid overage used in the calculation);

**Anti-Ice Rate** = setting the anti-ice control will run at (use all anti-ice liquid on board for a given route with a 5% liquid overage used in the calculation);

**Granular Capacity on the truck:**

**Auger setup screen** - granular capacity of the vehicle is added to the auger setup screen (shown in tons); This value will interact with the calculator in the following manner:

Sets the maximum amount of granular material the calculator will respond to  
 If the calculated amount of salt required by the liquid settings exceeds the capacity of the dump body/hopper, the word “over” appears instead of a value in the salt tons.

**Accept and Upload Values – “are you sure” warning**

Operator must accept the calculated values by choosing Y and hitting “pass (pause)” switch. If the operator doesn’t acknowledge the calculations, no change will occur with the rate settings and rates will stay as they were last set;

Once new rates are set, all other *SpreadSmart Rx*™ function keys will operate as normal. The operator can still change the rates using the auger & pre-wet.

**Rate Values do not re-set to zero automatically** – *SpreadSmart Rx*™ retains “last settings” on all of these values until:

New values are input or old values are cleared out;

Battery backup wears out (which would cause last settings to return to zero when the power is turned off);

**Display Route Miles (MiR):** displays a simple calculation of “miles remaining” for this route on the Automatic and No Speedo mode screens. Counts down the miles driven and subtracts from planned route miles. This display amount is accurate for route miles left, but can only be an estimate of material remaining since there is no accurate method to determine granular material remaining. Please note that spacing is very tight on the screen (this image is pretty close to final).

**Remaining capacities indicators:**

Miles left in route (MiR)

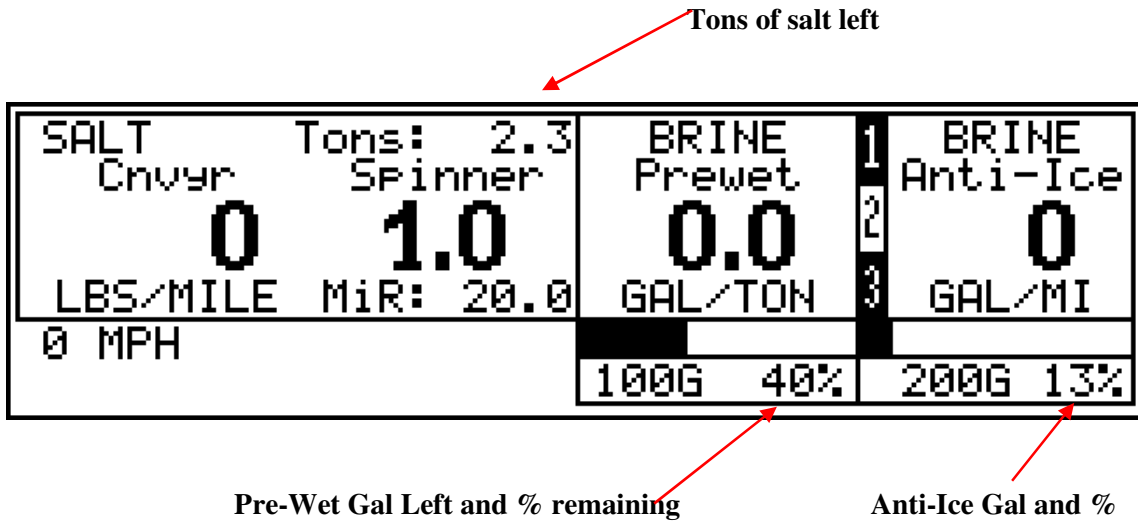

Miles left in route (MiR)

Tons of salt left

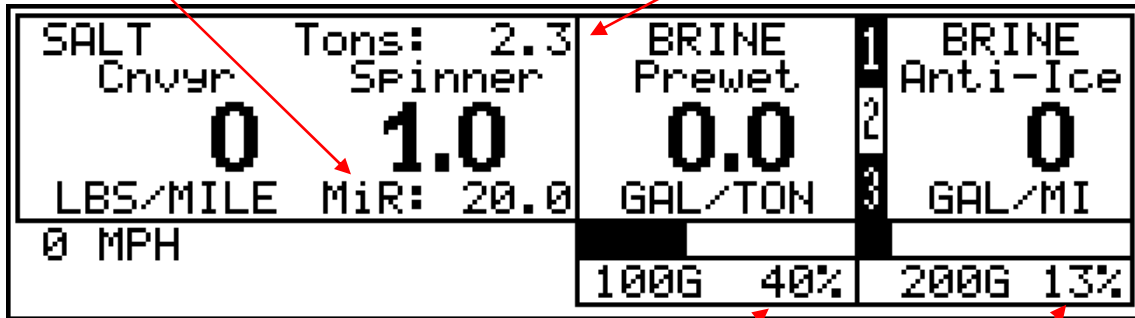

Pre-Wet Gal Left and % remaining

Anti-Ice Gal and % remaining

(note: in a partial fill situation, the % value and black bar graph will not start at 100%, but will end at 0% when tanks are empty);

### Spreading Rate Warnings

It is possible for operators to choose values that would, when operated, will result in warnings for over rate or under rate. Warnings occur during operation, not during rate calculations; Integrating warnings during calculations do not obviate the need for warnings that result from “normally calculated rates,” that cannot be achieved due to equipment set on the truck or the speed the truck is operated at.

### **Other Benefits from this Firmware:**

**Use this calculator for Granular only rate setting:** shut off the liquid section using on/off switch and run the calculator as normal. The granular rate and the number of tons to load will be calculated. Note that the Total App Rate will equal the Granular App Rate in this case.

### Using the system to re-calculate if things change

**How many miles are left on your route?** – observe MiR indicator on automatic screen;

**Calculate a new route with values from above?**

Use estimated gallons and tons from screen;

Open load and rate page from menu;

Input new liquid and granular route mileage and run calculator;

Note that basing a new route on the estimated values will not be accurate.

## **Operating Instructions- Other Settings**

Advanced calibration: This category of settings is the closed loop control settings for the hydraulics. These settings are set at the factory and rarely need to be changed. Please contact Cirrus Controls with any questions about these settings.

## **Other Settings- Return to Set Up Wizard**

Enter the configuration menu as before and select:

Set Up Wizard: system will run the set up wizard but will retain previous settings until you change them.

**Reset All:** This selection will clear all calibration data, reset the unit to factory defaults and resets the Set up Wizard. If you choose this action, you will be asked to confirm your selection before the unit is reset, to prevent accidental erasure of calibration settings. Use this selection to clear all memory and begin configuration with factory defaults.

## ***Configuration of System without using Set up Wizard***

Power up the unit & when the “mode” screen is displayed, simultaneously hold the auger and pre-wet switches down to enter the “configuration screen.” You will be asked for a password, enter it using the spinner controls to change the digits, and the blast/pass (pause) controls to change cursor positions. Run the cursor past the end of the password to enter “Configuration screen”. Because changing settings without authorization can result in performance variation, this password should only be given to authorized personnel. Move the arrow to “System set up” and select “pass (pause)” to enter the system set up.

## **Summary of Setup Parameters**

**Truck ID:** allows administrator to specifically identify the truck this *SpreadSmart Rx™* is installed in. This ID will be displayed on all truck specific data recorded by the *SpreadSmart Rx™*. Up to 24 alpha and/or numeric characters may be entered using “spinner up” to scroll through letters, “spinner down” to scroll through numbers and blast to move the cursor left or pass (pause) to move the cursor down. Any number of characters (up to 24) may be used for ID. When your ID characters are entered, use “pass (pause)” to scroll to the right to complete the ID and allow you to use “spinner” to move to the next step.

**Units (of measure):** records data and performs calculations in Standard (English) or Metric units. All data will be reported in the units chosen. Changing this setting will switch the unit to the preferred measurement system. Standard mode uses miles, pounds, gallons, and tons, - metric mode uses kilometers, kilograms, liters, and tons. Once you select a choice, all data must be input in those units. Mixed units will cause problems.

**PWM Frequency:** this value is set at the factory to match the frequency of the hydraulic valve coils in use. Normal operation does not include changing this value.

**Allow Dry Run:** This setting allows the operator to keep dispensing pre-wet or anti-ice material even if the flow sensor fails (applies to closed loop system only). This is set to NO by default to prevent the pre-wet pump from burning up if the flow meter detects no liquid flow (for example if the tank is empty). The pump automatically shuts off if this is the case. If this setting is set to YES, the operator can override this safety feature and continue dispensing pre-wet material in the case that there is a sensor failure.

**Password Test:** this feature allows the supervisor to set a password for the “Test” operating mode to stop unauthorized operators from entering mode. Default is “yes.”

**Password Manual:** this feature allows the supervisor to set a password for the “Manual”-operating operating mode to prevent unauthorized operators from entering that mode. Default is set to “no” since manual mode is a common operating mode.

**Password No GS:** this feature allows the supervisor to set a password for the “No Ground Speed” operating mode to prevent unauthorized operators from entering that mode. Default is set to “no”.

**Manual GS Trigger:** allows user to choose if Manual mode has a ground speed trigger or not. Default is Yes – when Manual mode is selected, spreading is triggered when the truck is moving and stopped when the truck stops.

**Number of Tanks:** one or two tanks can be selected. If truck has pre-wet only, select “1” tank; if truck has both pre-wet and anti-ice tanks, select “2.” If pre-wet and anti-ice are supplied from a single tank, select “1.”



Pre-Wet Tank Volume: use the anti-ice switch to scroll up or down to set the total volume of the tank used for pre-wet application. The units of measure (Gallons or Liters) are automatically chosen based upon your choice in “units of measure.”

Anti-Ice Tank Volume: use the anti-ice switch to scroll up or down to set the total volume of the tank used for anti-ice application. The units of measure (Gallons or Liters) are automatically switched based on the setting in “units.”

Blast Mode: Blast mode can be set to “toggle” on or off, operate as a “momentary” function or be set to run in a “timed on” fashion. Use the anti-ice switch to choose.

Blast Seconds: settable to the number of seconds (0-60) that the “Timed Blast” functions. Use the anti-ice switch to scroll up or down to make your selection.

Blast when stopped: choose yes to allow blast to function with truck standing still;

Blast resume after stop: choose yes to allow blast to start while stopped and continue once the truck is in motion.

Off Rate Minimum Speed: this setting determines the minimum speed above which the “off rate” alarm may function. At very low speeds (below 10 mph) this alarm is not useful and is quite annoying to the operator. Default is set at 10 mph.

Off Rate Dead band Percentage: this setting allows you to set the minimum amount of “off rate” error that will trigger the warning. Defaults are set to 50%.

Display Dead band Percentage: This setting determines the amount of variation in output that is displayed on the LCD. A lower value will cause the displayed value to rise and fall often because the full accuracy of the sensors is displayed. A larger value will make the display show less “variation.” Changing this setting does not change the amount of material being spread. Default is set to 25% of the range before a change is displayed.

Minimum Auto Mode Speed: These settings causes the *SpreadSmart Rx™* to respond to truck motion as if it was instantaneously at the minimum speed selected (mph). Default is 2mph. This setting is useful for applications with “start and stop” spreading (intersections etc) to spread more material since the truck speed is slow in an intersection. Speedometer display is not affected.

Maximum Speed Alert: use this setting to trigger an audible alarm when the truck exceeds the set speed. Default is set at 0, which means no alarm is enabled.

IP Address: this setting is factory set and must not be changed.

Subnet Mask: this setting is factory set and must not be changed.

Gateway: this setting is factory set and must not be changed.

Foreground download: select yes (default) for data download indication on LCD screen.

Log Interval: adjustable setting that determines how often *SpreadSmart Rx™* records data to the MMC Card. This setting is only active when combined with the Drive by Download Option.

Log interval is adjusted in the following increments using the “pass (pause)” switch: 5sec, 10 sec, 30 sec, 60 sec, 120 sec, 300 sec. The longer the interval, the less often data is recorded and the faster data can be transferred; the shorter the interval, the more often data is recorded and the slower data can be transferred.

Startup Timer: when set to “yes”, the SpreadSmart Rx counts 8 seconds after power up (when truck is started and SpreadSmart Rx is on) and defaults into automatic mode. The operator can start spreading as soon as the truck moves. When set to “no” the SpreadSmart Rx will power up and hold at the “mode screen” for the operator to choose his operating mode before beginning spreading.

Driver ID Required: answer yes to require the driver to enter his ID # to enable the system.

Temp Sensor Protocol: allows user to set SS Rx for both brands of temp sensors:

RS232 = Road Watch Brand (RW01-discontinued)

RS485 = Road Watch SS (current) or QTT Surface Patrol Brand

AVL Heartbeat On: Logs the firmware version and truck ID every log interval (5, 10, 30, 60, 120, 300 seconds) when turned on.

AVL Storm/Season Total On: Logs the Material Name, Storm Material Dispensed, and Season Material Dispensed every log interval (5, 10, 30, 60, 120, 300 seconds) when turned on.

Display AI x Booms On: When turned on the anti-ice displays the rate of material being dispensed which includes all booms. When turned off the anti-ice displays the rate/boom.

AVL Materials Freq. On: Logs the Materials Selection Log entry every log interval (5, 10, 30, 60, 120, 300 seconds) instead of only when materials are changed.

Materials Locked Count: Locks users without the supervisor password out of editing the first 'X' number of materials. Defaults to 6.

Cal Matl Password On: Enables the use of the Cal/Matl password.

Set Cal/Matl Password: Allows the user to change the password for Cal/Matl.

Set Test Mode Password: Allows the user to change the Test Mode password.

Summer Password On: Enables the use of the Summer password.

Set Summer Password: Allows the user to change the Summer password.

Enable Push Downloads: Method of downloading data from the spreader (default NO)

Dnld Psh Host IP: Server IP running DBD DCE for push downloads

Enable Audible Pass: When set to YES, will beep once when the spreader is set to PASS (Pause), and beep twice when leaving PASS (Pause). This feature is available in No Speedo, Manual, and Automatic modes.

Enable Preset Mat. Rates: When set to YES, provides 10 uniquely settable rates per material, per channel. When this feature is turned on, the auger, prewet and anti-ice channels must all use preset rates.

SD Calibration Available: After a successful wi-fi calibration file upload, the calibration data can be updated in the spreader by selecting PASS(Pause).

Enable UTC Log Files: Data logging is done in UTC time which requires a known time zone and daylight savings.

Enable Mat. Authorization: Materials can be entered into the system, but not visible in the Material Change menu if the material is disabled.

Use Previous SD Cal: After calibration is updated in a spreader using a calibration file downloaded via wi-fi, a copy of the previous calibration data is stored. If you want to go back to the previous calibration data, pres PASS(Pause).

Speedo Offset: Select Volvo trucks do not produce 0 ppm at 0 mph. If the vehicle does not produce 0 ppm at 0mph then select this option to add an offset to the speedo. Further information can be found in the tech note 16-002.

## Auger / Conveyor Set up and Trimming

<p style="text-align: center;"><b>WARNING</b></p> <p>Rev AG Copyright © 2014 by Cirus Controls, LLC. All Rights Reserved. No part of this document may be reproduced without the express written permission of Cirus Controls LLC for each reproduction.</p>		<p><b>Potential for injury due to unexpected operation of auger.</b></p> <p><b>Entanglement in the auger will cause severe injury to extremities, with possible loss of extremities.</b></p> <p><b>During initial startup and testing, the auger may start without warning. Stay clear of the auger during all startup, programming, and operation procedures.</b></p> <p><b>Do not attempt to clear a jammed auger with the hydraulic or control system active.</b></p>
--	---	--

4/7/2016

To trim the auger, power the unit up. Once the “mode” screen is displayed, simultaneously hold the auger and pre-wet switches down to enter the “configuration screen.” You will be asked for a password, enter “\_\_\_\_\_” using the spinner controls to change the digits, and the blast/pass (pause) controls to change cursor positions. Run the cursor past the end of the password to enter setup mode.

Using the spinner switch, select “Trim/Cal”, then select auger. The screen will now display the auger settings.

Auger Present: default is yes;

Sensor Present: choose NPN, PNP or No; Default is NPN;

Minimum Trim: do not adjust yet;

Maximum Trim: do not adjust yet;

Auger Units: choose either pounds per mile or ponds per lane mile (LN-MI);

Show as Conveyor: choose “no” to have the display use the word “auger.” Choose “yes” to have the display show the word conveyor.

Capacity in Tons (kg) – default setting is 10 tons. This value is used in conjunction with the load and rate calculator to verify that the amount of salt needed to meet the route & rate guidelines actually can be carried by the truck. Set up personnel should adjust this value to match the maximum tons of granular material the truck can carry.

Press the spinner control until the minimum trim setting is selected.

Press “*pass (pause)*” to enter trim calibration.

Choose either automatic (requires sensor) or manual (with or without sensor) calibration. The unit can automatically calibrate the trim settings using the sensor as feedback. (see “automatic” to continue). Automatic is recommended for most trucks. If you wish to manually trim the auger (faster for more experienced users), scroll and select manual trim (see manual calibration for rest of instructions).

### Manual Auger / Conveyor trimming (closed or open loop)

If you selected manual calibration, you must manually raise the hydraulic level using the auger switch and either observe the pulse count returning from the sensor (if equipped) or visually observe the auger motion. The spinner control is functional during auger trim calibration to prevent material piling up on the spinner.

Raise the hydraulic level (auger switch) until the auger is barely moving.

Press pass (pause) to accept this speed as the minimum trim level.

Increase the hydraulic level until maximum auger speed is achieved.

Press pass (pause) again to accept the maximum trim levels.

Once the maximum trim level is accepted, the user is asked to “accept calibration”. Select “Y” using the spinner control, and then press pass (pause).

The auger trim is now set, select blast to return to the main menu.

(Note: Do not adjust the factory settings for “pulses per pound.” They will be changed during the material drop test).

### Automatic Auger / Conveyor Trimming

If you selected automatic trim calibration, the unit automatically selects the trim levels using the sensor as feedback. **The spinner control is functional during auger trim calibration, to prevent material piling.**



Potential for injury due to unexpected operation of auger.

Entanglement in the auger will cause severe injury to extremities, with possible loss of extremities.

During initial startup and testing, the auger may start without warning. Stay clear of the auger during all startup, programming, and operation procedures.

Do not attempt to clear a jammed auger with the hydraulic or control system active.

Step through the on screen instructions using the pass (pause) switch to begin trim calibration. Once initiating auto trimming, you have 10 seconds to raise the engine RPM. Hold RPM constant while unit is calibrating. This may take as much as two minutes. (You may cancel the trim test at any time using the blast key.) Once the automatic trim calibration test is completed, the user is asked to “accept calibration”. Select “Y” using the spinner control, and then press pass (pause).

## Spinner and Zero velocity Set Up and Baseline Trimming

### Standard Spinner Configuration and Trimming

Enter the configuration menu and select trim/cal as before. Select spinner trim.

Spinner Setup		Page 1/2
→ Spinner Present:	Yes	
Sensor Present:	Yes	
Zero Velocity:	No	
Show Spinner in %:	No	
Spinner Stops With Truck:	No	
<SPIN+/->=sel <ICE+/->=adj <BLAST>=done		

Spinner Present: Set to yes if spinner present.

Sensor Present: Default is “no” because most systems do not have a spinner sensor, and systems with a spinner sensor require a special pigtail.

Zero velocity: if your spinner is a zero velocity type, answer yes. If not, answer no. If you answer yes, the screen will change to “zero velocity set-up.”

Show Spinner in %: answer yes to show spinner in % output instead lanes.

Spinner Stops with Truck: answer yes to allow the spinner to keep spinning very slowly while the truck is stopped in order to keep the hydraulic fluid moving and warm. The auger is stopped when truck motion is stopped. Choose “no” to stop spinner when truck is stopped.

Spinner Setup		Page 2/2
→ One Lane Speed:	1579	
One Lane Blast Speed:	1579	
Three Lanes Speed:	1579	
Three Lanes Blast Speed:	1579	
<SPIN+/->=sel <ICE+/->=adj <BLAST>=done		

Press the spinner control until the one lane speed setting is selected.

**Note this step is usually done without material in the truck, for the purpose of estimating final spinner trim settings and to allow the truck to enter “un-calibrated automatic mode”.**

<p>Rev AG Copyright © 2014 by Cirrus Controls, LLC. All Rights Reserved. No part of this material may be reproduced without the express written permission of Cirrus Controls LLC for each reproduction.</p>	<p><b>WARNING</b></p>  <p>Potential for injury due to unexpected operation of spinner. Granular material thrown off the spinner will cause severe eye injury, with possible permanent loss of vision. Contact with a moving spinner will cause injury to extremities and other body parts. During initial startup and testing, the spinner may start without warning. Stay clear of the spinner during all startup, programming, and operation procedures. Do not attempt to clear a jammed spinner with the hydraulic or control system active.</p>	<p>4/7/2016</p>
--	---	-----------------

**Set the Trim for the Rotational Speed of the “One Lane Setting” (minimum trim):**

Enter the configuration menu and select trim/cal as before. Select spinner trim. Select the “one-lane wide” trims setting and follow the on screen instructions. Increase the auger setting until a “normal” auger speed is occurring. Increase the spinner setting until a “one-lane wide” spinner speed is occurring (note: this rotational speed is your estimate based on observation of the spinner speed. Accurate calibration will be done later)

Press pass (pause) to accept the “one lane” speed setting.

**Set the Trim for the Rotational Speed of the “Three Lane” Setting (maximum trim):**

Select the “three-lane wide trims” setting and follow the on screen instructions. Increase the auger setting until a “normal” auger speed is occurring. Increase the spinner setting until a three-lane wide spinner speed is occurring (note: this rotational speed is your estimate and must be faster than the setting you chose in the one-lane wide step. Accurate calibration will be done later).

Press pass (pause) to accept the “three lane” speed setting.

**Note:** at this stage, the trims for 1 and 3 –lane blast settings are the same as those chosen here. Final settings for Blast will be completed during the calibration step.

**Zero velocity spinner configuration**

Enter the configuration menu and select trim/cal as before. Select spinner trim.

Spinner Present: Set to yes if spinner present.

Sensor Present: set to yes for Zero velocity spinner;

Zero velocity: set to yes for Zero velocity spinner

Minimum Trim: see below;

Maximum Trim: see below;

Pulses Per Revolution: enter the rated pulses per revolution of the sensor on the Zero velocity spinner;

Overdrive %: leave at default value.

Impeller Diameter (inches): enter size of impeller in inches.

Hotkey mode switch: allows single key switching between auto/MPH and manual control of zero velocity spinner. Default is no.

**Hotkey Mode:** allows the operator to switch from ground speed oriented operation of the ZV spinner to manual mode (manual control of output based on % of total output) with a single “hotkey.” Enable the hotkey in the set up of the spinner (above):

Zero Velocity Setup page 1/2	Zero Velocity Setup page 2/2
→ Spinner Present: Yes	→ Pulses Per Revolution: 10
Sensor Present: Yes	Overdrive Percent: 20%
Zero Velocity: Yes	Impeller Diameter (in): 16.0
Minimum Trim: 2380	Hotkey Mode Switch: Yes
Maximum Trim: 9469	
<SPIN+/->=sel <ICE+/->=adj <BLAST>=done	<SPIN+/->=sel <ICE+/->=adj <BLAST>=done

Toggle between MPH (auto) and Manual (%) with “pass (pause)” enabled, with one click of spinner.

While “pass (pause)” is off, toggle between functions by holding spinner (-) till it reaches 0 and switches to Manual mode. Hold spinner up to raise manual output, down to lower, 0 plus one click to return to MPH mode.

Granular - SALT Auger @ velocity <b>1700</b> LBS/MILE	<b>11</b> MPH	BRINE Prewet <b>61.5</b> GAL/TON	KC12 Anti-Ice <b>48</b> GAL/MI	Granular - SALT Auger @ velocity <b>1650</b> LBS/MILE	Manual <b>50%</b>	BRINE Prewet <b>61.5</b> GAL/TON	KC12 Anti-Ice <b>48</b> GAL/MI
21 MPH <PASS>		59%	89%	21 MPH		56%	83%

### Select Manual or Automatic Trim

- Press the spinner control until the minimum trim setting is selected.
- Press “pass (pause)” to enter trim calibration.
- Choose either automatic (requires sensor) or manual (with or without sensor) calibration. The unit can automatically calibrate the trim settings using the sensor as feedback.

### Manual Zero velocity Trimming – Recommended

If you selected manual calibration, you must manually raise the hydraulic level using the spinner switch, and observe the pulse count returning from the sensor or visually observe the Zero velocity motion. The auger switch must also be raised until the auger is moving throughout the trimming step.

Raise the hydraulics (Spinner switch) until the zero velocity spinner is barely moving.

Press pass (pause) to accept this speed as the minimum trim level.

Increase the hydraulic level until maximum zero velocity speed is achieved.

Press “pass (pause)” again to accept the maximum trim levels.

Once the maximum trim level is accepted, the user is asked to “accept calibration”. Select “Y” using the spinner control, and then press pass (pause).

The zero velocity trim is now set, select blast to save and return to the main menu.

### Automatic Zero velocity Trimming – Closed loop only

If you selected automatic trim calibration, the unit automatically selects the trim levels using the sensor as feedback.

Step through the on screen instructions using the pass (pause) switch to begin trim calibration.

Once initiating auto trimming, you have 10 seconds to raise the engine RPM.

Hold RPM constant while unit is calibrating. This may take as much as two minutes. (You may cancel the trim test at any time using the blast key.)

Once the automatic trim calibration test is completed, the user is asked to “accept calibration”.

Select “Y” using the spinner control, and then press pass (pause).

The zero velocity trim is now set, select blast to save and return to the main menu.

## Pre-Wet Pump Set up and Trimming

<p><b>WARNING</b></p>		<p>Potential for injury due to unexpected operation of liquid spray system. High-pressure liquid spray will cause severe eye injury, with possible permanent loss of vision. During initial startup and testing, the liquid system may start without warning.</p> <p><b>Wear face and eye protection when working with active high-pressure spray systems.</b></p>
<p>Rev AG Copyright © 2014 by Cirus Controls, LLC. All Rights Reserved. No part of this written permission of Cirus Controls LLC for each reproduction.</p>	<p>Page 42</p>	<p>4/7/2016</p>

## **VERIFY THAT FLUID IS PRESENT IN TANKS BEFORE BEGINNING OPERATION.**

Power the system down and up and enter the configuration menu as before. Then, using the spinner switch, select trim/cal and select pre-wet. The screen will now display the pre-wet settings. Use anti-ice toggle to change settings.

Prewet Present: default is yes;

Sensor Present: choose NPN, PNP or No; Default is NPN;

Minimum Trim: do not adjust yet;

Maximum Trim: do not adjust yet;

Pulses per Gallon: enter the pulses per gallon rating of your flow meter. Refer to flow meter manufacturer to determine the signal pulses sent by the flow meter for each gallon (or liter if set in metric mode).

Micro Trak FM500 – flow meter used by Cirus Controls

**Gallons: Pulses per gallon = Flow cal number / 2**

**Liters: Pulses per gallon = Flow cal number / 7.58**

Raven brand flow meters are listed in pulses per 10 gallons.

divide the flow meter rating by 10 and input that value.

**Note: units of measure here must match units of measure in master set up. If you are changing from English to Metric units, you must start at the first setup step and be consistent or calibration errors will occur;**

Pump max. Gal/minute: enter the max output rating of your pre-wet pump.

Prewet Units: choose between gallons/ton (default setting) and gallons/mile

Press the spinner + control until the minimum trim setting is selected.

Press pass (pause) to enter trim calibration.

Choose either automatic (requires flow meter) or manual (with or without flow meter) calibration. The unit can automatically calibrate the trim settings using the sensor as feedback. If you wish to manually trim the pre-wet pump (faster for more experienced users), select manual trim.

### **Automatic Pre-Wet Pump Trimming and Calibration**

If you selected auto trimming, the unit automatically selects the trim levels using the flow sensor. Step through the instructions using the pass (pause) switch to begin trim calibration.

Once initiating auto trimming, you have 10 seconds to raise the engine RPM.

Hold RPM constant while unit is calibrating. This may take as much as two minutes. (You may cancel the trim test at any time using the blast key.)

Once the automatic trim calibration test is completed, the user is asked to “accept calibration”.

Select “Y” using the spinner control, and then press pass (pause).

Press blast to accept all settings.

Trimming and Calibration is complete, select blast again to save and return to main menu.

### **Manual Pre-Wet Pump Trimming and Max Flow Setting**

If you selected manual trimming, you must manually raise the hydraulic level using the pre-wet switch, and either observe the pulse count returning from the flow sensor (if equipped) or visually observe fluid being dispensed.

Raise the hydraulic level (pre-wet toggle) until the pre-wet pump is barely pumping.

Press pass (pause) to accept minimum trim level.

Increase the hydraulic level until maximum pre-wet fluid flow is achieved.

Press pass (pause) again to accept the maximum trim levels.

Once the maximum trim level is accepted, the user is asked to “accept calibration”. Select “Y” using the spinner control, and then press pass (pause).

If the vehicle does not have a pre-wet flow meter, open loop trimming is used. In this case, enter the maximum pump flow for the pump installed (gallons or liters /minute), the *SpreadSmart™* unit will use this value to calculate the amount of pre-wet material dispensed. In an open loop system, recording of amount of material dispensed by the system is based on a system that is not “calibrated” and therefore is not a “certifiable” value.

## Anti-Ice System – Configuration and Trimming Steps

1) To configure the anti-ice system, power the unit up. Once the “mode” screen is displayed, simultaneously hold the auger and pre-wet switches down to enter the “configuration screen.” You will be asked for a password, enter “\_\_\_\_\_” using the spinner controls to change the digits, and the blast/pass (pause) controls to change cursor positions. Run the cursor past the end of the password to enter setup mode.

2) Using the spinner switch, select “Trim/Cal”, and scroll down to “anti-ice” and push pass (pause) to select. This will put you at the Anti-Ice Setup and make selections. Use Anti-Ice +/- to toggle between Yes (Y) and No (N).

Anti-Ice Present – answer yes to activate system;

Sensor Present – Sensor Present: choose NPN, PNP or No; Default is NPN;

Minimum Trim – do not adjust value from factory pre-sets until the next section...trimming.

Maximum Trim – do not adjust value from factory pre-sets until the next section...trimming.

Multi-Tier System – yes for two tier system, no for single tier boom system;

Anti-Ice uses Prewet channel: answer yes for special use of pre-wet plumbing and extra spraying apparatus controlled like Anti-Ice, but using Pre wet hydraulics. Special use only.

Pulses per Gallon: enter the pulses per gallon rating of your flow meter. Refer to flow meter manufacturer to determine the signal pulses sent by the flow meter for each gallon (or liter if set in metric mode).

Micro-Trak FM500 – flow meter used by Cirus Controls

**Gallons: Pulses per gallon = Flow cal number / 2**

**Liters: Pulses per gallon = Flow cal number / 7.58**

Raven brand flow meters are listed in pulses per 10 gallons.

divide the flow meter rating by 10 and input that value.

**Note: units of measure here must match units of measure in master set up. If you are changing from English to Metric units, you must start at the first setup step and be consistent or calibration errors will occur;**

Pump max. Gal/minute: enter the max output rating of your anti-ice system pump.

Tier 1 Max GPM: Enter the maximum flow rate of the Tier 1 booms (in gallons per minute).

This setting is the point at which the Tier 2 –High Flow Booms turn on. See table below for



reference. Note: early versions of *SpreadSmart Rx*<sup>TM</sup> named this function “Tier 2 GPM.” The value entered is the same as Tier 1 max GPM.

Tier 2 Max GPM. Enter the maximum flow rate of the Tier 2 booms (in gallons per minute).

This setting is the point at which the system turns both tiers on. Note: if you have answered yes to “use single tier relay,” this question is not asked on the screen.

Earlier versions of *SpreadSmart Rx*<sup>TM</sup> named this function as “Tier 1+ Tier 2 GPM.” The value to enter is the same as the Tier 2 max GPM.

Use spinner + to return to the minimum trim line.

Boom 1 Disabled: When set to Yes, boom 1 will not be displayed on the screen and always turned off.

Boom 2 Disabled: When set to Yes, boom 2 will not be displayed on the screen and always turned off.

Boom 3 Disabled: When set to Yes, boom 3 will not be displayed on the screen and always turned off.

### Anti-Ice Pump Trimming

<b>WARNING</b>		<p>Potential for injury due to unexpected operation of liquid spray system.</p> <p>High-pressure liquid spray will cause severe eye injury, with possible permanent loss of vision.</p> <p>During initial startup and testing, the liquid system may start without warning.</p> <p>Wear face and eye protection when working with active high-pressure spray systems.</p>
----------------	---	---

**VERIFY THAT FLUID IS PRESENT IN ANTI-ICE TANK BEFORE BEGINNING.**

Turn on all boom valve switches on keypad (3),

Press spinner + to reach the “minimum trim” line. .

Press “pass (pause)” to enter trim calibration.

Enable at least one boom control valve switch.

Choose either automatic (requires flow meter) or manual (with or without flow meter) calibration.

The unit can automatically calibrate the trim settings using the sensor as feedback or manually (faster for more experienced users), by selecting “manual”.

#### Automatic Anti-Ice Pump Trimming and Configuration

If you selected auto trimming, the unit automatically selects the trim levels using the flow meter (sensor) as feedback.

Step through the instructions using the pass (pause) switch to begin trim calibration.

Once initiating auto trimming, you have 10 seconds to raise the engine RPM.

Hold RPM constant while unit is calibrating. This may take as much as two minutes. (You may cancel the trim test at any time using the blast key.)

Once the automatic trim calibration test is completed, the user is asked to “accept calibration”. Select “Y” using the spinner control, and then press pass (pause).

Trimming and Configuration is complete, select blast again to return to main menu.

#### Manual Anti-Ice Pump Trimming and Max Flow Setting

If you selected manual trimming, you must manually raise the hydraulic level using the Anti-Ice switch, and either observe the pulse count returning from the flow sensor (if equipped) or visually observe fluid being dispensed.

Raise the hydraulic level until the Anti-Ice pump is barely pumping.

Press pass (pause) to accept minimum trim level.

Increase the hydraulic level until maximum Anti-Ice fluid flow is achieved.

Press pass (pause) again to accept the maximum trim levels.

Once the maximum trim level is accepted, the user is asked to “accept calibration”. Select “Y” using the spinner control, and then press pass (pause).

If the vehicle does not have a Anti-Ice flow meter, open loop trimming is used. In this case, enter the maximum pump flow for the pump installed (gallons or liters /minute), and the *SpreadSmart Rx™* unit will use this value to calculate the amount of Anti-Ice material dispensed. In an open loop system, recording of amount of material dispensed by the system is based on a system that is not “calibrated” and therefore is not a “certifiable” value.

## Validation of Flow Meter Ratings using SpreadSmart Rx

**Confirm your Calibration:** to validate that you are delivering the planned amount of fluid from your liquid system regardless of which flow meter is in use, use the following method:

Plumb your liquid system to allow you to catch and measure an amount of fluid from a single port (2-3 gallons or 8-12 liters). Add enough fluid to do the calibration;

From the menu screen, select Test mode, enter the password;

Menu	v4.15 Rx	Test Mode	
Automatic Mode	Help	Enter Password:	
Manual Mode	→ Test Mode	[*000]	
No Speedo Mode	Material Change	⟨SPINNER +/-⟩ to change	
Unload Mode	Fill Tanks	⟨BLAST⟩=back	
Storm/Season Tot.	Diagnostics	⟨PASS⟩=next/done	
⟨SPINNER +/-⟩=select		⟨PASS⟩=next/done	

Ramp up the output on the liquid system in use until the pulses coming back are equal to the flow cal number (such as 1500). Liquid will be flowing at this point:

Granular - SALT Auger Spinner	BRINE Prewet	KC12 Anti-Ice
0% 1660 PPM	25% 1660 PPM	30% 1660 PPM
Speedo: 0 PPM NO GPS		
TEST   ⟨BLAST⟩=done ⟨PASS⟩=zero		

Collect fluid for exactly one minute. The volume of fluid collected is equal to the volume flowing in one minute. Because the test mode allows you to see pulses expressed in ppm (pulses per minute), the amount of fluid you collect will tell you if your pulses per gallon (or liter) rating on the flow meter is correct for the spreader control.

If the test gives you more or less fluid than you expected (off by more than 3%), adjust the pulses per gallon (liter) in the spreader setup to compensate for the variation you experience.

The variation is most likely due to the fact that different flow meters are calibrated using different methods and different fluids, not because of any problem with the flow meter or the spreader control.

Flow meters supplied by Cirus Controls will have the correct pulses/gallon conversion shown on the actual flow meter for use during the set up step.

## Granular Calibration Validation

The Cal Validation diagnostic option provides a process to confirm that calibration settings are correct without the vehicle moving. Using the calibration settings in the spreader, 100 lbs (50 kg in metric mode) of granular material is dispensed. You then weigh that material to validate the accuracy of the calibration. The spreader simulates dispensing granular material at a rate of 100 lbs/mi (25kg/km in metric mode), and speed of 30 mph (60km/hr in metric mode) for two minutes. After two minutes, the simulation covers 1 mile (2km in metric mode) and dispenses 100 lbs (50 kg in metric mode) of granular material. If the material dispensed is not 100 lbs (50kg in metric mode) +/- 5lbs, the vehicle should be recalibrated following the procedure for the granular drop test.

To run a Calibration Validation follow these steps:

Be certain that the granular material you wish to validate the calibration of is selected as the current granular material. The current granular material selected can be verified by selecting Automatic or No Speedo Mode to view the material name.

From the Main Menu, choose Diagnostics. Press pass (pause).

Menu		v6.70 Rx
Automatic Mode	Load/Rate Calc.	
Manual Mode	Test Mode	
No Speedo Mode	Material Change	
Unload Mode	Fill Tanks	
Storm/Season Tot.	→ Diagnostics	
<SPINNER +/->=select		<PASS>=accept

In the Diagnostics Menu go to Cal Validation. Press pass (pause).

Diagnostics	
Firmware versions	Automatic Mode
MMC/SD Data Card	MDM Module
GPS Antenna	Speedometer
RoadWatch	Help
Auto Gate	→ Cal Validation
<BLAST>=done <SPIN+/->=sel <PASS>=next	

An overview of the test parameters is displayed on the screen. Press pass (pause).

Calibration Validation Parameters	
Granular Rate = 100 lb/mi	
Speed = 30 mph	
Validation Duration = 2 minutes	
Select PASS to Start the Validation	
<BLAST>=done	<PASS>=test

Make sure to clear personnel away from the auger. Press pass (pause).

```

Diagnostics
-----
WARNING!
Continuing sets the auger in motion.
Stay away from auger during test.
Bring engine to spreading RPM.
-----
<BLAST>=done                <PASS>=test

```

If a closed loop auger is used, the display will show the amount of time the test has been running, feedback pulses, and the amount of material dispensed.

```

Diagnostics
-----
Time (s) 9   of 120
Pulses Per Minute (PPM) 1009
Material Dispensed (lbs) 4
-----
<BLAST>=STOP                <PASS>=STOP

```

Open loop calibration displays the amount of time the test has been running, and the amount of material the spreader has calculated it dispensed.

```

Diagnostics
-----
Time (s) 4   of 120
Material Dispensed (lbs) 3
-----
<BLAST>=STOP                <PASS>=STOP

```

When the test has concluded, the text VALIDATION COMPLETE will appear on the display.

```

Diagnostics
-----
Time (s) 120 of 120
Material Dispensed (lbs) 100
      VALIDATION COMPLETE
-----
<BLAST>=done                <PASS>=done

```

After two minutes of the test, 100 lbs (50 kg in metric mode) of material should be dispensed. If this is not the case, the controller needs to be re calibrated.

## Optional Equipment

### 7 and 10” Camera Ready Color TFT Display – Touch screen

*SpreadSmart*™ is available with an optional 7” and 10” color displays, with “dual function” showing *Uni-Grip*™ plow control and *SpreadSmart Rx*™ information on a single display.

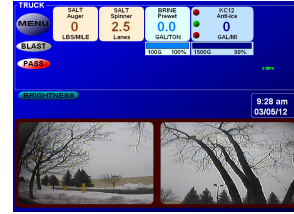
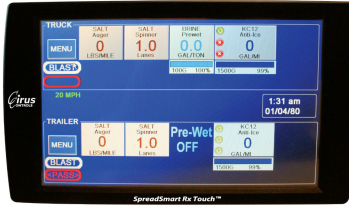

Touch screen control interface systems require the touch screen M12 interface PCBA for the CPU.

## In Dash Mount on International Cabs

The color display is also available with mounting hardware for installation into the dash board cubby hole on International Trucks.

## Temperature Sensor

*SpreadSmart Rx*™ is capable of receiving temperature data from the following sensors:

- Road Watch – Protocol = RS485 setting; Input connector = DB-9;
- QTT Surface Patrol - Protocol = RS485 setting; Input connector = DB-9

**Note:** To operate correctly, the protocol must be set to match the brand of Temp Sensor plugged into the system. See the system set up detail to correctly set the protocol. Prior versions of SS Rx required a jumper change to match sensor brand. Jumpers are no longer required for temp sensors.

## GPS Receiver – for position and/or speedo signal source

*SpreadSmart Rx*™ is capable of receiving positional data from a compatible GPS receiver, the Garmin 17N and recording it onto its optional MMC card. Download of GPS data requires the use of the optional Drive by Download system. Installation instructions are included.

GPS Data: real time GPS data is displayed in two modes on the *SpreadSmart Rx*™.

GPS Data Screen: this screen displays all of the data being received by the system: Current Latitude, Longitude, Current Date and Time (shown in Greenwich Mean Time-GMT), current speed and current direction of travel (compass). This screen is accessed from the mode menu.

- Power system up.
- Before the system drops into automatic mode (10 seconds on a calibrated truck), hold the “auger” switch down and the “pre-wet” switch up to enter the GPS data screen. This screen displays data and no operator changes are available. This screen is not accessible while the truck is in any normal operating mode (i.e. while the truck is moving and spreading).

**Test Mode:** this operating mode includes display of latitude and longitude and is normally used for system level testing and not for “regular spreading of material.”

## Drive by Download™ (DBD) – See DBD 3.x operation manual

System Overview: This optional system includes a high volume data storage device and the hardware to download stored data using a 802.11 b/g/n Wi-Fi® connection with a base station computer (*Drive By Download*™). The software installed on the base station PC called

*DRIVEBY.EXE* manages the process of downloading data from the *SpreadSmart Rx™* to the base station and tracks/displays the “download status” of each truck in the DBD network. Once the spreading data has arrived on the base station computer, software called *REPORT.EXE* is used to create seven standard spreading performance reports that allow the user to analyze the performance of one or several trucks over any time period for which there is stored data.

### **Download Frequency**

For the smoothest data transfer operation, we recommend that *SpreadSmart Rx™* data be downloaded each time the truck returns to the base station from a spreading run. The “download interval” is settable in *DRIVEBY.EXE*, and specifies how long the *Drive By Download™* data manager waits after a download before attempting a new download. The more often the data is downloaded, the quicker the download process occurs.

### **Foreground/Background Download**

*SpreadSmart Rx™* can be configured to allow download in the foreground (operator gets a warning the download is underway and cannot spread during downloading) or background (operator gets no warning that downloading is underway). Default is “foreground downloading.” Background downloading will display a “d” in the top left corner of Main Menu screen.

### **Download Time**

The time it takes for data to be transferred from the *SpreadSmart Rx™* to the base station computer is a function of the amount of data stored on *SpreadSmart Rx™* MMC card. The amount of data stored between downloads is dependent on the “log interval” set on your *SpreadSmart Rx™* and the amount of spreading that occurs. Each site will want to adjust its “log interval” in the system set up to collect data at the optimum frequency.

### **Log interval**

*SpreadSmart Rx™* is continuously recording data in RAM, but writes that data to the MMC card as often as the “log interval” determines. A 60 second interval is recommended. Longer log intervals result in data being stored less often and transfer speed increasing, shorter intervals result in data being stored more often and slower transfer speeds.

The *SpreadSmart Rx™* has storage capacity up to 1 Gigabyte of data. We recommend that data be downloaded at least once a month. The base station PC should be located at the site where the trucks return with the most regularity.

### **Data Linkage Range:**

Linkage range is no more than 250 feet with a clear line of site between the truck transmitter antenna and the wireless access point antenna at the base station. Linkage range may be longer, but must be verified at the site.

## **Material Detection Module™ (MDM)**

MDM is a “plug in” accessory module to accommodate digital and/ or analog sensor inputs that will integrate in any *SpreadSmart™* product. The module includes additional “open” inputs.

### **Functional Description of MDM integrated with SpreadSmart:**

#### **Gate Height Control:**

**Gate Height Sensor:** when operated in automatic mode, the *SpreadSmart™* monitors the gate height setting and adjusts the conveyor speed to compensate for that setting to deliver the desired amount of material. Calibration of the gate height and granular material are required for accurate operation of the system.

**Auto Gate:** adjusts the gate height via hydraulic control to optimize the gate height setting for any desired speed and application rate combination

**Hopper Level Sensing:** when installed, the hopper level is monitored by the *SpreadSmart™* and warns the operator with audible and visual alarm when the hopper level falls below the position of the sensor in the dump body.

**Granular Material Flow Sensing:** when installed, the granular sensor is monitored by *SpreadSmart™* and warns the operator when material is **not** moving past the sensor.

**Pressure Sensor Display:** when installed with the optional Color display, the *SpreadSmart™* system displays hydraulic pressure from a pressure sensor in hydraulic system.

**Direct Cast:** when installed, adjusts the spinner rate dependant on the position of direct cast. Used on color displays.

**Backup Cameras:** allows up to 2 cameras to be triggered into full screen camera mode.

**Installation:** the MDM is designed to be installed in the cab of the truck in close proximity to the *SpreadSmart™* CPU.

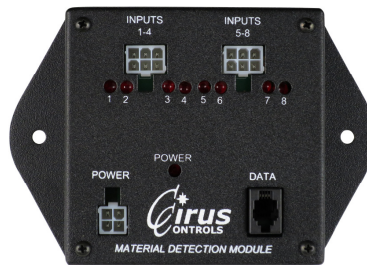

1) Connect all cables:

DC 1000 - Multi-plex input cable; connect to MDM 400 module;

- |                                     |                                |
|-------------------------------------|--------------------------------|
| a) Hopper sensor                    | molex connector 1; MDM Input 1 |
| b) Gate Height sensor               | molex connector 2; MDM Input 2 |
| c) Material Flow sensor             | molex connector 3; MDM Input 3 |
| d) Hydraulic pressure sensor        | molex connector 4; MDM Input 4 |
| e) Direct Cast/Gran Material sensor | molex connector 1; MDM Input 5 |
| f) Backup Camera 1 sensor           | molex connector 2; MDM Input 6 |
| g) Backup Camera 2 sensor           | molex connector 3; MDM Input 7 |

DC 1001 and DC 1002 – sensor input cables. Choose for proper connection to sensors in use. Plug into DC-1000 cable as shown above.

HH1001 -Cirrus Bus Cable; connect to Bus port on MDM 400 and on *SpreadSmart™* CPU.

MK 1003 – Power cable, connect to 12v supply, ignition hot and battery ground;

**Configuration:** Turn on *SpreadSmart™* and enter the configuration menu as before.

```

Configuration
Setup Wizard          Advanced
System Setup         Set Clock
+ Trim/Cal           Reset All
Materials            Save and Exit
<BLAST>=done <SPIN+/->=sel <PASS>=next

```

```

Trims/Calibration
Auger                Speedo
Spinner              + MDM Module
Prewet
Anti-Ice
<BLAST>=done <SPIN+/->=sel <PASS>=next

```

Select Trim/Cal and select MDM Module:

Enable Sensors installed in the truck using “anti-ice +/-” key to choose yes or no.

```

MDM Module Setup      Page 1/3
+ MDM Module Present: Yes
Hopper Sensor:       Yes
Invert Hopper Signal: No
Material Flow Sensor: Yes
Invert Flow Signal:  No
<SPIN+/->=sel <CON+/->=adj <BLAST>=done

```

```

MDM Module Setup      Page 3/3
+ Gate Height Sensor: No
Default Gate Setting: ( 50) 3.0
Low Gate Setting:     ( 10) 1.0
High Gate Setting:    (190) 10.0
<SPIN+/->=sel <CON+/->=adj <BLAST>=done

```

### a) Calibrate the Gate Height Sensor

**Default Gate Height setting:** choose this opening size and always use this opening size for material calibration steps. Use “anti-ice +/-” key to raise or lower this value (allowable range is 1.5 to 24 inches). Select “default gate height setting” and hit “pass (pause).”

```

Gate Height Sensor Setting
Set gate height at 3.0 inches.
Current sensor reading: <118>
<BLAST>=cancel <PASS>=accept

```

Move to rear of truck and set gate height to the actual value (inches) that corresponds to the value you have selected here. The sensor will respond with the “current sensor reading” value (as above). Hit pass (pause) to accept the setting and return to the MDM setup page 2. Repeat calibration steps for both the low and high gate setting;

```

MDM Module Setup      Page 3/3
+ Gate Height Sensor: No
Default Gate Setting: ( 50) 3.0
Low Gate Setting:     ( 10) 1.0
High Gate Setting:    (190) 10.0
<SPIN+/->=sel <CON+/->=adj <BLAST>=done

```

Use “blast” key to return to running menu and save the new configuration.

#### Configure the other sensors attached to the system:

\* **Pressure Sensor:** use “anti-ice” key to raise or lower sensor low and high values using the specified values supplied with the sensor chosen. Refer to the below table for the two types of pressure ratings.

```

MDM Module Setup      Page 2/3
Pressure Sensor:      Yes
Sensor Low Voltage (Vlo): 0.5
Pressure at Vlo:      0
Sensor High Voltage (Vhi) 5.5
+ Pressure at Vhi:     1600
<SPIN+/->=sel <CON+/->=adj <BLAST>=done

```

*The pressure transducer values must match the values for the pressure transducer installed into the valve; otherwise, the psi ratings will not be accurate on the display.*

<b>Pressure Transducer Settings:</b>	<b>1450psi Transducer</b>	<b>3625psi Transducer</b>
Sensor Low Voltage (Vlo)	.1	.1
Pressure at Vlo	0	0
Sensor at High Voltage (Vhi)	10	10



Pressure at Vhi	1450	3625
-----------------	------	------

- b) Use blast key to return to menu screen and save changes;  
c) Cycle the power on SpreadSmart Rx™ and the pressure should now display on the screen. Operate system to verify proper pressure display on the display. Independent verification of pressure can be accomplished by reading a gauge installed on the valve assembly and comparing it to the pressure on the *SpreadSmart Rx*™ display.

\* **Hopper Level Sensor:** refer to sensor installed to determine if hopper signal is to be inverted.

MDM Module Setup		Page 1/3
MDM Module Present:	Yes	
Hopper Sensor:	Yes	
Invert Hopper Signal:	No	
→ Material Flow Sensor:	Yes	
Invert Flow Signal:	No	
<SPIN+/->=sel <CON+/->=adj <BLAST>=done		

MDM Module Setup		Page 1/3
MDM Module Present:	Yes	
Hopper Sensor:	Yes	
Invert Hopper Signal:	No	
→ Material Flow Sensor:	Yes	
Invert Flow Signal:	No	
<SPIN+/->=sel <CON+/->=adj <BLAST>=done		

\* **Material Flow Sensor:** refer to sensor installed in truck to determine if material flow signal needs to be inverted.

**Diagnostics:** Use diagnostics screen for verification of operation of the MDM system.

Diagnostics	
→ Firmware versions	Automatic Mode
MMC/SD Data Card	MDM Module
GPS Antenna	Speedometer
RoadWatch	
<BLAST>=done <SPIN+/->=sel <PASS>=next	

Diagnostics	
MDM Module Attached:	Yes
Hopper Sensor:	Full
Gate Height:	4.3
<BLAST>=done	

## Automatic Proportional Gate Control Instructions

**Purpose:** This function adjusts the gate height via hydraulic control to optimize the gate height setting for any desired speed and application rate combination. The gate height controls the amount of material dispensed for a certain amount of linear distance travelled by the conveyor in a center conveyor spreading system. The controller keeps the speed of the conveyor in its “sweet spot” to achieve ideal control over the material dispensed.

**Functionality:** The gate height adjustment is completely automatic requiring no operator control. The *SpreadSmart Rx*™ system will output an up and down signal to a flow controlled pair of valves that will raise and lower the gate via a hydraulic ram. The output from the *SpreadSmart Rx*™ system will be a pair of signals to move the gate up and down as desired. The inches (cm) per second of gate travel will need to be confirmed during setup. The system will adjust the gate height no more than every 30 seconds in order to eliminate surging. The input to the *SpreadSmart Rx*™ system will be the current method of reading gate height using an MDM module and the variety of sensors this system supports.

### Wiring Implementation:

Gate Control only -cable # GHS-8003 plugs into the “anti-ice boom” port;  
Gate Control and Anti-Ice Booms – TS-8003a/Ts-8003d cables.

### System Setup

Power up the unit & when the “mode” screen is displayed, simultaneously hold the auger and pre-wet switches down to enter the “configuration screen.” You will be asked for a password, enter it using the spinner controls to change the digits, and the blast/pass (pause) controls to change cursor positions. Run the cursor past the end of the password to enter “Configuration screen”. Move the arrow to “TrimCal” and select <pass (pause)> to enter the system set up.

1) Go to the MDM module; enable it and the gate height sensor (page 2).

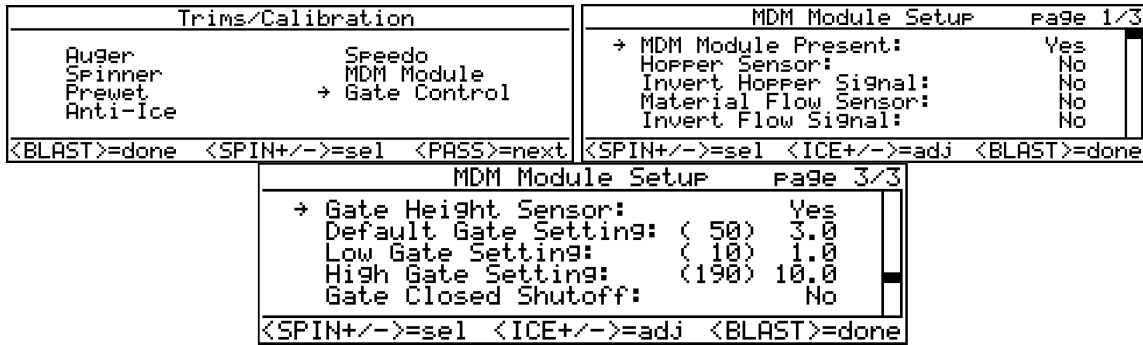

2) Go to the Gate Control section and enable auto gate:

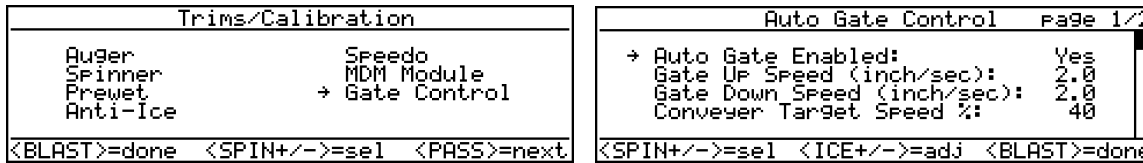

3) Calibrate the Gate Height Sensor – return to the MDM module on the Trim/Cal page;

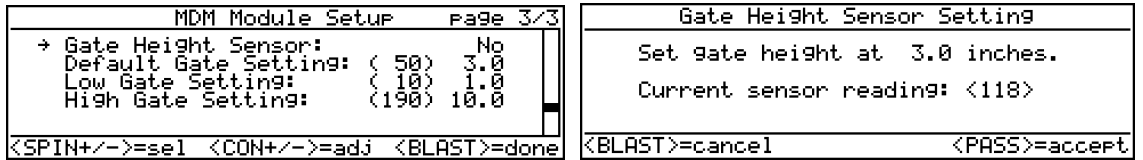

- a.) **Default Gate Height setting:** choose the default gate opening you prefer and always use this opening size for material calibration steps. Use “anti-ice +/-” key to raise or lower this value (allowable range is 1.5 to 24 inches). Record your default gate (inch) preference and <blast> back to save your settings. Return to the main menu screen.
- b.) **Enter into Diagnostics-Auto Gate** on the main menu screen and manually toggle the spinner switch +/- to match the default height value (inches) from the back of the truck that was previously recorded in step “a”. An extra person is helpful for this measurement.



- c.) **Return to MDM module on the Trim/Cal page** and <pass (pause)> into the Default Gate Setting; the sensor will update the *SpreadSmart Rx*™ with the “current sensor reading” value (below). Hit <pass (pause)> to accept the setting and return to the MDM Module Setup page 3/3. Repeat calibration steps “A” thru “C” for both the low and high gate settings;

<pre> MDM Module Setup      Page 3/3 + Gate Height Sensor:  No   Default Gate Setting: ( 50) 3.0   Low Gate Setting:    ( 10) 1.0   High Gate Setting:   (190) 10.0           </pre>	<pre> Gate Height Sensor Setting Set gate height at 3.0 inches. Current sensor reading: &lt;118&gt;           </pre>
<pre> &lt;SPIN+/-&gt;=sel &lt;CON+/-&gt;=adj &lt;BLAST&gt;=done           </pre>	<pre> &lt;BLAST&gt;=cancel &lt;PASS&gt;=accept           </pre>

Use the <blast> key to return to the main menu; this will save the new configuration.

#### 4.) Enter into the Auto Gate Control and conduct the Automatic Trim Procedure

The Auto Gate Control enables the auto gate function for automatic mode and no speedo mode only. The **Up Speed** is the rate at which the gate opens when the coil is activated. This controls the timing of the gate when the auto gate function is used. The down speed is the other direction of the cylinder. The **Target Conveyor Rate** is how fast (as a percentage of max speed) the **SpreadSmart Rx**™ targets the conveyer to run. This rate needs to be set on the **SpreadSmart Rx**™ during the setup procedure.

<pre> Auto Gate Control      Page 1/2 + Auto Gate Enabled:   Yes   Gate Up Speed (inch/sec): 2.0   Gate Down Speed (inch/sec): 2.0   Conveyor Target Speed %: 40           </pre>	<pre> Auto Gate Control      Page 2/2 + Gate Update Speed (sec): 15   Show Target Height:      Yes           </pre>
<pre> &lt;SPIN+/-&gt;=sel &lt;ICE+/-&gt;=adj &lt;BLAST&gt;=done           </pre>	<pre> &lt;SPIN+/-&gt;=sel &lt;ICE+/-&gt;=adj &lt;BLAST&gt;=done           </pre>

The **update rate** (seconds) is how often the gate height is evaluated and if necessary, changed. This prevents surging.

**Automatic Trim Procedure:** *Caution the gate will move make sure all personal stay clear before proceeding.* Pressing <PASS (PAUSE)> on either the “Gate Up” or “Gate Down” speed will run the automatic calibration for the “Gate up/down” speed settings. Follow the on screen instructions:

<pre> Auto gate speed cal is a 3 step process 1) Gate will close to lowest position. 2) Gate will open to read up speed. 3) Gate will close to read down speed. SpreadSmart will tell you when it's done Press &lt;BLAST&gt; to cancel at any time.           </pre>	<pre> Gate Height 1.0 inches           </pre>
<pre> &lt;BLAST&gt;=cancel &lt;PASS&gt;=start           </pre>	<pre> Opening gate for 2 seconds Gate Speed Trim   &lt;BLAST&gt;=cancel           </pre>

The calibration routine will run the gate cylinder all the way down to the minimum and then measure the gate to make sure it's down. The **SpreadSmart Rx**™ will then run the gate up for 2 seconds. This allows it to measure the gate to get the distance travelled, and divides by 2, giving the speed in inches/sec (or cm/sec for metric mode). It then runs the gate up again for 2 seconds to give the cylinder enough room to do the down calibration in case the down speed is faster. It takes the top measurement, runs the gate down two seconds, and takes the down reading. The **SpreadSmart Rx**™ will then ask you to confirm the settings.

The auto gate is now ready to run.

Additional components in diagnostics are also in place to help troubleshoot problematic setups

Diagnostics		Auto Gate Control Disabled	
Firmware versions	Automatic Mode	MDM Module Not Enabled	
MMC/SD Data Card	MDM Module	MDM Module Not Present	
GPS Antenna	Speedometer	Gate Sensor Not Present	
RoadWatch	Help		
→ Auto Gate			
<BLAST>=done <SPIN+/->=sel <PASS>=next		<BLAST>=done	

Maximum output in “dump” mode functions in “automatic” and “no ground speed” modes only, as no speed signal is present in manual mode.

## Direct Cast Control Instructions

**Purpose:** This function adjusts the spinner rate depending on the Direct Cast angle which is between 30 degrees left or right of center.

**Functionality:** The spinner responds to the calibrated rate while positioned in the center at 0 degrees. As Direct Cast switches position to the left or right the spinner rate is increased. The amount of spinner rate increase (Boost) is configurable in the *SpreadSmart Rx* between 0 and 100. 0 produces the least amount of boost while 100 is the maximum. A visual representation for the direction Direct Cast is pointing and spread width is available in Auto, Manual, No Speedo and Test modes in the spreader. For each of these modes the boost is calculated to create the spinner rate. Examples of Direct Cast visual representation:



0 degrees < 1.0 lanes



0 degrees 1.0 ≤ lanes ≤ 2.0



0 degrees lanes > 2.0

## System Setup

Verify the Direct Cast Sensor is plugged into the number 5 input of the MDM Module. Power up the unit & when the “mode” screen is displayed, simultaneously hold the auger and prewet switches down to enter the “configuration screen.” You will be asked for a password, enter it using the spinner controls to change the digits, and the blast/pass (pause) controls to change cursor positions. Run the cursor past the end of the password to enter “Configuration screen”. Move the arrow to “TrimCal” and select <pass (pause)> to enter the system set up.

### 1) Go to the MDM module

```

Trims / Calibration

Auger                               Speedo
Spinner                             > MDM Module
Prewet                              Gate Control
Anti-Ice

<BLAST> = done   <SPIN+/-> = sel   <PASS> = next

```

## 2) Enable the MDM module

```

MDM Module Setup           page 1 / 5

> MDM Module Present:           Yes
Hopper Sensor:                 No
Invert Hopper Signal:          No
Material Flow Sensor:          No
Invert Flow Signal:            No

<SPIN+/-> = sel   <ICE+/-> = adj   <BLAST> = done

```

## 3) Enable Direct Cast

```

MDM Module Setup           page 4 / 5

> Direct Cast Enable:           Yes
Direct Cast Left (V):           0.0
Direct Cast Center (V):         5.0
Direct Cast Right (V):          10.0
Direct Cast Boost:              0

<SPIN+/-> = sel   <ICE+/-> = adj   <BLAST> = done

```

## 3) Calibrate the left 30 degree sensor setting

```

MDM Module Setup           page 4 / 5

> Direct Cast Enable:           Yes
Direct Cast Left (V):           0.0
Direct Cast Center (V):         5.0
Direct Cast Right (V):          10.0
Direct Cast Boost:              0

<SPIN+/-> = sel   <ICE+/-> = adj   <BLAST> = done

```

## 4) Set the Direct Cast spinner to the far left position to calibrate

```

Direct Cast Sensor Setting
-----
Set Direct Cast Left at
current sensor reading: 0.0 Volts
-----
< B L A S T > = c a n c e l           < P A S S > = a c c e p t

```

**5) Calibrate the center sensor setting**

```

MDM Module Setup           page 4 / 5
-----
Direct Cast Enable:                Yes
Direct Cast Left (V):              0.0
> Direct Cast Center (V):          5.0
Direct Cast Right (V):             10.0
Direct Cast Boost:                 0
-----
< S P I N + / - > = s e l   < I C E + / - > = a d j   < B L A S T > = d o n e

```

**6) Set the Direct Cast spinner to the center position to calibrate**

```

Direct Cast Sensor Setting
-----
Set Direct Cast Center at
current sensor reading: 5.0 Volts
-----
< B L A S T > = c a n c e l           < P A S S > = a c c e p t

```

**7) Calibrate the right 30 degree sensor setting**

```

MDM Module Setup           page 4 / 5
-----
Direct Cast Enable:                Yes
Direct Cast Left (V):              0.0
Direct Cast Center (V):            5.0
> Direct Cast Right (V):           10.0
Direct Cast Boost:                 0
-----
< S P I N + / - > = s e l   < I C E + / - > = a d j   < B L A S T > = d o n e

```

**8) Set the Direct Cast spinner to the far right position to calibrate**

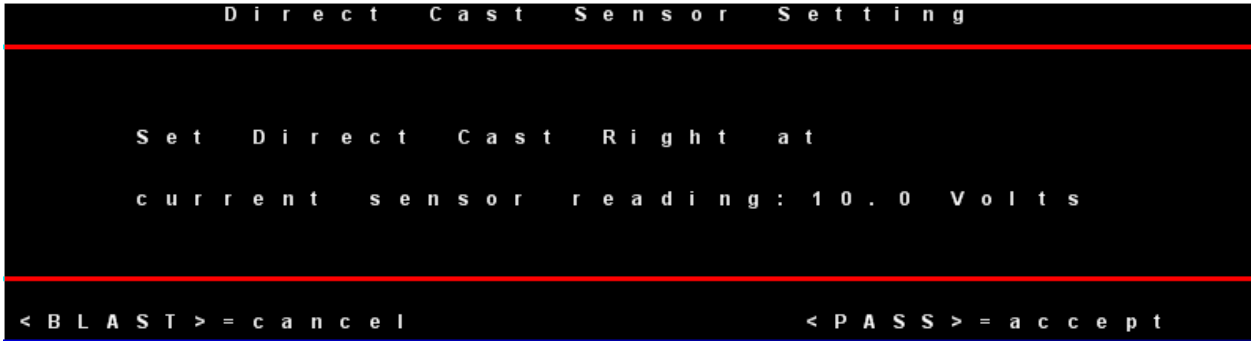

### 9) Set the Direct Cast boost

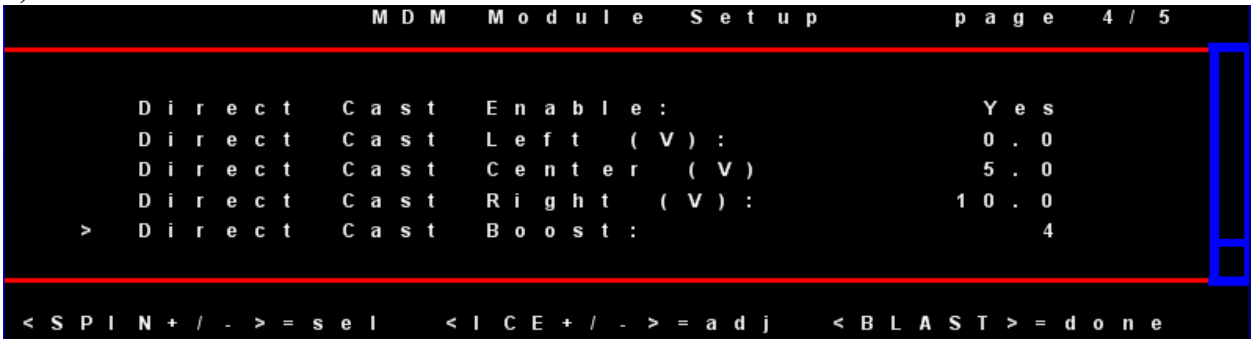

A value of 0 for Direct Cast Boost provides the least amount of boost, while 100 provides the maximum boost.

### 10) Click <BLAST> 3 times to save the settings.

## Backup Camera Instructions

**Purpose:** This function allows up to two cameras to be triggered by an external source.

**Functionality:** The number 6 and 7 inputs of the MDM module are used to trigger a camera to go into full screen camera mode. The display will exit the full screen camera mode when the trigger has been removed. Input 6 triggers camera 1 and takes precedence over input 7 which triggers camera 2. The camera triggers are active in all menu and mode screens for the *SpreadSmart Rx*. Great White displays using two *SpreadSmart Rx* spreaders have the option to use two MDM modules which allows for four triggers.

### System Setup

Power up the unit & when the “mode” screen is displayed, simultaneously hold the auger and prewet switches down to enter the “configuration screen.” You will be asked for a password, enter it using the spinner controls to change the digits, and the blast/pass (pause) controls to change cursor positions. Run the cursor past the end of the password to enter “Configuration screen”. Move the arrow to “TrimCal” and select <pass (pause)> to enter the system set up.

### 1) Go to the MDM module

```
Trims / Calibration

Auger                               Speedo
Spinner                             > MDM Module
Prewet                              Gate Control
Anti-Ice

<BLAST> = done   <SPIN+/-> = sel   <PASS> = next
```

### 2) Enable the MDM module

```
MDM Module Setup                       page 1 / 5

> MDM Module Present :                Yes
Hopper Sensor :                       No
Invert Hopper Signal :                 No
Material Flow Sensor :                 No
Invert Flow Signal :                   No

<SPIN+/-> = sel   <ICE+/-> = adj   <BLAST> = done
```

### 3) Enable the Backup Camera

```
MDM Module Setup                       page 5 / 5

> Backup Camera On :                  Yes
Backup Cam 1 Trigger (V) :            5.0
Backup Cam 2 Trigger (V) :            5.0

<SPIN+/-> = sel   <ICE+/-> = adj   <BLAST> = done
```

### 4) Set the Minimum Voltage Required to Trigger Camera 1

```
MDM Module Setup                       page 5 / 5

Backup Camera On :                    Yes
> Backup Cam 1 Trigger (V) :          5.0
Backup Cam 2 Trigger (V) :          5.0

<SPIN+/-> = sel   <ICE+/-> = adj   <BLAST> = done
```

### 5) Set the Minimum Voltage Required to Trigger Camera 2



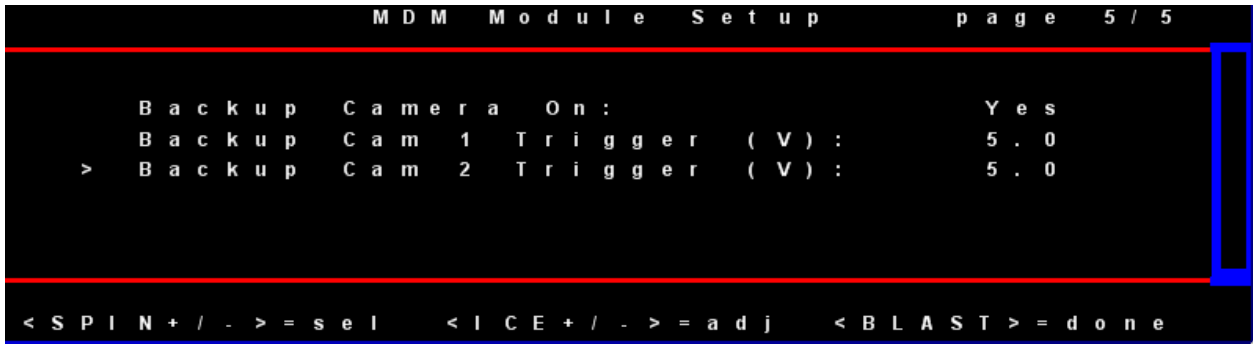

## Granular Material Switching Using the MDM Module

The Granular material being dispensed can be switched between any two of the granular materials already set up in the *Spreadsmart Rx*™. The “MDM Module Present” and “MDM Gran Switch Enabled” settings must be set to YES in the MDM Module Setup. The two materials can then be selected. The high voltage material Hi(V) will be used when the MDM Channel voltage is greater than 5 volts. The low voltage material Lo(V) will be used when the MDM Channel voltage is lower than 5 volts. Channel 5 of the MDM Module is used to control this feature.

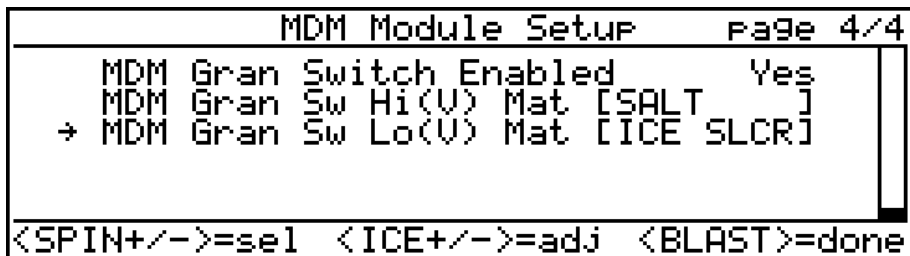

## 7 Inch Touch Screen Calibration Instructions

### 7” Touch Display Requirements:

- 1) *Spreadsmart Rx*™ touch compatible CPU box;
- 2) 7” Touch TFT screen with firmware 2.23 or higher
- 3) Stylus or a stylus substitute such as a pen.

### 7” Touch Display Calibration Instructions:

- 1.) Power up the 7” display and the spreader. Navigate to the Diagnostics Screen from the main menu.

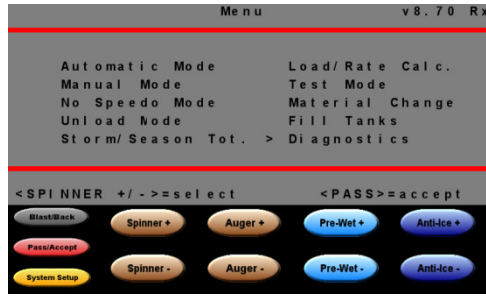

2.) Touch the “Click To Start Touch Calibration Screen” button.

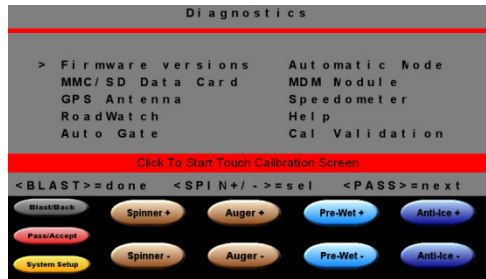

3.) Using the stylus touch the crosshair on the display to move to the next crosshair to complete the 5 point calibration shown below.

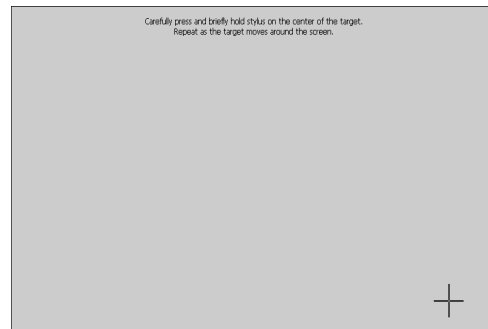
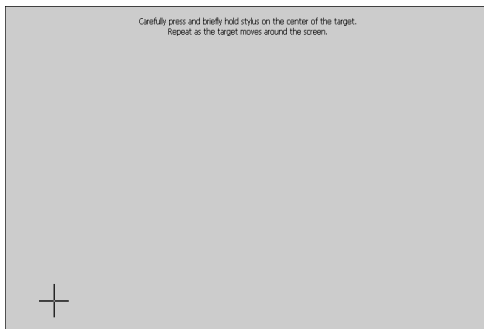



**\*Note: If the crosshair continues to loop back to the center of the screen, make sure you are using a stylus and touching the center of the crosshair.**

4.) Touch anywhere on the display to complete calibration.

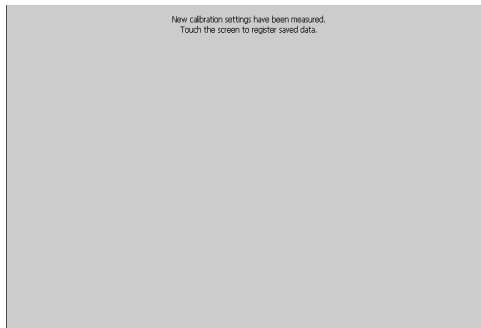

5.) Touch the 'OK' button on the Registry Save message box (or touch anywhere on the 7" display) and calibration is complete.

## **MATERIAL AUTHORIZATION**

The material authorization feature is disabled by default in the SSRx (system operates with all materials available). To control materials at the supervisory level, the material authorization feature must be turned on in system setup. Once the feature is enabled, materials become selectable for use only when they are enabled and calibrated.

One material for the auger, prewet, and antiice is always required to be enabled.

Granular material disabled – Driver cannot view the material name in the material change list and therefore cannot select it for use.

Granular material trimmed and enabled but not calibrated – Driver can view the material in the material change list. Material cannot be selected from the material change list by the driver and has a line through the material index #. Supervisor can access and calibrate each material using the system set up menu.

Granular/Prewet/Antiice enabled and not trimmed – viewable and selectable in the material change list.

Prewet/Antiice material disabled - Driver cannot view the material name in the material change list and therefore cannot select it for use.

Material cannot be selected from the material change list by the driver and has a line through the material index #. Supervisor can access and calibrate each material using the system set up menu.

*Calibrated materials are defined as follows:*

Granular - Materials which have successfully completed the SSRX calibration routine.

## **SpreadSmart System Troubleshooting Guide**

<b>Complaint</b>	<b>Cause (s)</b>	<b>Correction (s)</b>
<b>Set Up Issues</b>		
Power Isn't On	a) Master Power Off; b) Fuse is blown; c) Bad Power or Ground connection;	a) Turn on green master power switch and switch panel power; b) Replace Fuse (s) c) Verify power/ground connections.
SpreadSmart Rx cuts out or acts strange;	Low power supply voltage from truck battery/alternator;	Minimum truck voltage must be > 12.0 volts;
No speedometer signal appears during test mode.	a) Speedometer cable failure; b) Signal offset needs adjustment (VRM speedometer only);	a) Repair/replace speedometer cable; b) Adjust trim pot for VRM signal;
Auger or Spinner Doesn't Move	a) PTO not engaged; b) Hydraulics not functioning;  c) Electrical connection failure;  d) Spreader power off;	a) Engage PTO; b) Verify Hydraulics: actuate plow or hoist; manually operate using manual over-ride on valve; c) Check LED at coil connection and at Valve junction box; Repair cable connections; d) Check wiring connections;
Auger/Spinner move, but output rates not indicated	a) Auger sensor failure;  b) Sensor flashes, but signal not displayed in Test mode;	a) Check sensor wiring and sensor function; b) Check sensor signal cable; verify that spreader setup shows "sensor present";
<b>Operating Modes</b>		
Automatic mode is unavailable ( <del>Automatic</del> )	a) Installed systems are not set up and trimmed properly; b) System(s) not installed in truck, but enabled in controller setup & not trimmed (anti-ice not installed)	a) Follow Set Up and Trim procedure; b) Follow set up procedure and turn off any systems not installed in truck;
Pre-Wet or Anti-Ice will not display when panel switch is turned on;	Pre-Wet or Anti-Ice not "enabled" during system set up;	Follow Set Up and Trim procedure to enable functions;
Settings on display are shown in % (not in lbs/mile);	a) Automatic mode: System is not set up and trimmed properly; b) Manual mode is selected;	a) Follow Set Up and Trim procedure; b) Select Automatic mode;
Flow Rate won't calibrate	a) Flow meter inaccurate (meter, sensor or cable);  b) Units conversion error	a) Use test mode to compare pulses to volume of liquid flowing. Replace meter or sensor if needed; b) SS Rx must be set in the desired units (English or metric) before any setup occurs. Re-start complete setup procedure with units set correctly;
Spinner Runs Continuously	Spinner set not to stop with truck;	Follow Spinner set up procedure;
Unable to maintain steady application at set rate (low speed);	a) Auger is not trimmed properly for low speed operation; b) Advanced settings need adjustment (sticky valves);	a) Re-trim hydraulic system to improve low speed performance; b) Adjust parameters – qualified technician only;
SS Rx display goes blank and functions stop (on a system that was working normally before the event);	Probable shorted or open circuit externally – most often with a sensor, but may be a damaged cable connection.	a) Disconnect Hyd Out, Sensor In & Anti-ice Booms. If SS Rx display comes back, one of them has a open/short;

		b) Re-connect cables one at a time to determine damaged component; c) Replace damaged component;
Multiple Tier Anti-Ice System does not switch tiers at desired speed;	Anti-Ice Tiers not configured to switch at desired speed (or output amount);	Follow anti-ice set up procedure to set the parameters for tier 1 and tier 2 operations.
<b>Alarm Conditions</b>	<b>Cause (s)</b>	<b>Correction (s)</b>
Off Rate Alarm Sound/Flash	Actual material dispensed does not match rate setting;	a) Clear auger or spinner jam; b) Re-Trim system to improve consistency;
Auger Alarm Sound/ Flash	a) Auger stopped; b) Auger sensor failure; c) Minimum trim too low; d) Stuck or sticky valve;	a) Clear Auger jam; b) Repair Sensor & or cable; c) Adjust minimum trim; d) Adjust “coil unseat” settings; repair valve coil
Pre-Wet or Anti-Ice Alarm Sounds/Flash	a) Pre-Wet Pump Stopped; b) Pre-Wet Sensor Failure; c) Minimum trim too low; d) Stuck or sticky valve;	a) Repair pump/clear obstruction; b) Repair sensor & or cable; c) Adjust minimum trim; d) Adjust “coil unseat” settings; repair valve coil
Alarm keeps sounding (applies to all alarms);	System needs to be re-set; Alarm display will remain until root condition is corrected;	Turn off main power (green switch) and then re-start;
<b>Speedometer Alarm</b>	<b>Cause (s)</b>	<b>Correction (s)</b>
	a) Speedometer signal lost; b) Speedometer not calibrated;	a) Verify cable connections; b) Follow Speedo set up steps;
<b>Display</b>		
LCD too dark or too light	Contrast setting needs to be changed;	Simultaneously raise “auger” and “pre-wet” paddles to enter contrast mode. Raise or lower “spinner” to change contrast.
LCD Display Changes	Some variation is normal	Re-set contrast as needed;
LCD is Blank	CPU Lock Up; LCD Failure; LCD Cable Failure	a) Master System Reset (power); b) Replace LCD; c) Replace LCD Cable;
LCD Display Locks up	CPU or Data Lockup	Master System Reset (power)
<b>Data Logging</b>		
Storm & or Season totals don’t match material dispensed;	a) Inaccurate calibration during drop test;  b) Operating sometimes in manual and sometimes in automatic during dispensing;	a) Re-run granular drop test and validate calibration for automatic mode; b) No dispensation data is recorded in manual mode. If accurate data is required, run in automatic mode;
Cannot download calibration data from SpreadSmart Rx to PC;	a) Bad connection between PC and SpreadSmart Rx; b) PC operating system must be Windows 2000 or newer;	a) Validate cable connections between systems; b) Use PC with compatible operating system;
Cannot upload calibration data from PC to SpreadSmart Rx;	a) Bad connection between PC and SpreadSmart Rx; b) Data file not selected (highlighted) when initiating upload.	a) Validate cable connections between systems; b) Select the data file you wish to upload before pressing, “send calibration” on “sprdutil.exe”.

## Diagnostics – on board

SpreadSmart Rx includes on board diagnostics for a number of key functions. To enter the Diagnostics section, first enter the mode screen by pressing the “Menu” switch and choose diagnostics.

## Glossary of Terms

### Master System Settings

**Truck ID** – name of the truck in which the system is installed

**Units (Metric or English):** select the units that the system uses. (All calibrations will be lost when changing from Metric to English or vice-versa.)

**Default Screen Contrast:** setting for screen contrast (no units).

**PWM Frequency:** setting for frequency of PWM signal (in Hz).

**Password Manual Mode:** choose to select password protection for “Manual” mode or not.

**Password No Speedo Mode:** choose to select password protection for “no speedo” mode or not.

**Password Test Mode:** password protection for “Test” mode or not.

**Allow Wet Fail Override:** setting to “yes” allows operator to over-ride of safety protection of Prewet/Anti-Ice system.

**Blast Mode:** select between on/off, timed or momentary start operation.

**Blast Seconds:** amount of time the timed blast runs (1-60 seconds).

**Minimum Off-rate Speed:** determines the minimum speed (mph) above which the “off rate” alarm will function.

**Off Rate Dead band:** percentage of “off rate” error allowed prior to triggering warning.

**Display Dead band:** determines the percent of variation in output that is displayed on the LCD.

**High Frequency Speedo:** select yes or no depending upon the type of speedometer input.

**Number of Liquid Tanks:** tells the system how many liquid tanks are present.

**Prewet Tank Capacity:** capacity of the pre-wet tank.

**Anti-Ice Tank Capacity:** capacity of anti-ice tank.

**IP Address:** Unique internet address of this SpreadSmart Rx. Used for *Drive by Download™*.

**Subnet Mask:** Unique subnet mask address of this SpreadSmart Rx. Used for *Drive by Download™*.

**Log Interval:** adjustable setting that determines how often *SpreadSmart Rx™* records data to the MMC Card.

### Auger Settings

**Device Present:** select yes or no to tell the controller that an auger is present.

**Device Has Sensor:** select yes or no to tell the controller that an auger sensor is present.

**Minimum Trim PWM:** PWM value at which the auger starts moving. Value determined at “trim” step.

**Minimum Trim PPM:** Pulse per minute value received from sensor running at minimum trim.

**Maximum Trim PWM:** PWM value when auger hits maximum speed. Value determined at “trim” **Maximum Trim**

**PPM:** Pulse per minute value received from sensor when running at maximum trim **Default Pulses Per Pound:**

Default value for each material choice. Set at 5.0

**Default PWM-t Per Pound:** Open loop PWM to pounds conversion ratio. Set at 5.0

**Auger Units:** select granular distribution rate in pounds/mile or pounds/lane-mile.

### Auger Advanced Settings -

**Lock Strength:** (deleted as of v 3.17). Set at 0 and do not adjust.

**Lock Increment:** SpreadSmart Rx PWM response increment. Set at 70 (no units). Increasing value causes spreader to attempt to correct more frequently causing display to be more jumpy.

**Update Laps:** Feedback adjustment response cycle rate. Allows coil to react. Set at 3 cycles. Increasing value makes controller respond more slowly, decreasing makes controller respond more rapidly.

**Unseat Drive Percent:** % of trim signal used to unseat valve at motion startup. Set at 50%

(Used to unseat sticky valves)

**Unseat Time:** Length of time that unseat signal is sent. Set at 10 (1 equals one tenth of second).

### Spinner Settings

**Device Present:** select yes or no to tell the controller that a spinner is present.

**Device Has Sensor:** select yes or no to tell the controller that a spinner sensor is present.

**Minimum Trim PWM:** PWM value where spinner starts spinning. Value determined at “trim” step.

**Minimum Trim PPM:** Pulse per minute value received from sensor running at minimum trim.

**Maximum Trim PWM:** PWM value when spinner hits max speed. Value determined at “trim”

**Maximum Trim PPM:** Pulse per minute value received from sensor when running at maximum trim.

**Zero velocity:** yes or no tells the controller is zero velocity spinner is present (closed loop system only).

**1 Lane Normal PWM:** PWM Value when spinner delivers 1-lane width pattern, normally a 12 ft wide pattern. Value determined at “trim” step and actual 1-lane disbursement width can be adjusted to end-user preference.

**1 Lane Normal PPM:** Pulse per minute value received from spinner sensor when running at “1 lane wide” trim.

**1 Lane Blast PWM:** Max trim value with 1 lane width spinner. Value determined at “trim” step.  
**1 Lane Blast PPM:** Pulse per minute value received from spinner sensor when running at maximum (blast) trim.  
**3 Lane Normal PWM:** PWM Value when spinner delivers 3-lane width pattern, normally a 36 ft wide pattern. Value determined at “trim” step and actual 3-lane disbursal width can be adjusted to end-user preference.  
**3 Lane Normal PPM:** Pulse per minute value received from spinner sensor when running at “3 lane wide” trim.  
**3 Lane Blast PWM:** Max trim value with 3 lane width spinner. Value determined at “trim” step.  
**3 Lane Blast PPM:** Pulse per minute value received from spinner sensor (if installed) when running at max (blast) trim  
**Spinner Stops With Truck:** optional selection to allow spinner to run when truck stopped while in auto.  
**Spinner Always On (obsolete):** no longer functional, will be removed in future designs.  
**Zero velocity Overdrive:** allows Zero velocity to run slightly slower (neg.) or faster (pos) than truck speed.  
**Zero velocity Pulses Per Revolution:** Sensor signal pulses/rev. Default is 4.0  
**Zero velocity Impeller Diameter:** Unique value for a given Zero velocity system (inches).

#### Spinner Advanced Settings

**Lock Strength:** Set at 0 and do not adjust.  
**Lock Increment:** SpreadSmart Rx PWM response increment. Set at 70 (no units). Increasing value causes spreader to attempt to correct more frequently causing display to be more jumpy.  
**Update Laps:** Feedback adjustment response cycle rate. Allows coil to react. Set at 3 cycles. Increasing value makes controller respond more slowly, decreasing makes controller respond more rapidly.  
**Unseat Drive Percent:** % of trim signal used to unseat valve at motion startup. Set at 50% typically.  
**Unseat Time:** Length of time that unseat signal is sent. Set at 10 (1 equals one tenth of second).

#### Prewet Settings

**Device Present:** select yes or no to tell the controller that an pre-wet pump is present.  
**Device Has Sensor:** select yes or no to tell the controller that a pre-wet sensor is present.  
**Minimum Trim PWM:** PWM value when Prewet pump starts pumping. Value determined at “trim” step.  
**Minimum Trim PPM:** Pulse per minute value received from flow sensor with system running at min. trim.  
**Maximum Trim PWM:** PWM value when pre-wet pump hits max output. Value determined at “trim”  
**Maximum Trim PPM:** Pulse per minute value received from flow sensor when system is running at maximum trim.  
**Pulses Per Gallon:** Input value from the flow meter on the pre-wet system. Key conversion factor.  
**Pump Max. Gallon/Minute:** Input value from the pre-wet pump rating. Limit of open loop output.

#### Pre-Wet Advanced Settings

**Lock Strength:** Set at 0 and do not adjust.  
**Lock Increment:** SpreadSmart Rx PWM response increment. Set at 70 (no units). Increasing value causes spreader to attempt to correct more frequently causing display to be more jumpy.  
**Update Laps:** Feedback adjustment response cycle rate. Allows coil to react. Set at 3 cycles. Increasing value makes controller respond more slowly, decreasing makes controller respond more rapidly.  
**Unseat Drive Percent:** % of trim signal used to unseat valve at startup. Set at 50% (To unseat sticky valves)  
**Unseat Time:** Length of time that unseat signal is sent. Set at 10 (1 equals 0.1 second).

#### Anti-Ice Settings:

**Device Present:** select yes or no to tell the controller that an Anti-Ice pump is present.  
**Device Has Sensor:** select yes or no to tell the controller that an Anti-Ice sensor is present.  
**Minimum Trim PWM:** PWM value when anti-ice pump starts pumping. Value determined at “trim” step  
**Minimum Trim PPM:** Pulse per minute value received from flow sensor when system is running at minimum trim.  
**Maximum Trim PWM:** PWM value at anti-ice pump max output. Value determined at “trim” step.  
**Maximum Trim PPM:** Pulse per minute value received from liquid flow sensor when system is running at max. trim.  
**Pulses Per Gallon:** Input value from the flow meter on the anti-ice system. Key conversion factor.  
**Pump Max. Gallon/Minute:** Input value from the anti-ice pump. Limit of open loop output.  
**Tier 1 Gallon/Minute:** Maximum flow rate of the Tier 1 booms (in gallons per minute)  
**Tier 2 Gallon/Minute:** Maximum flow rate of the Tier 2 booms (in gallons per minute).

#### Anti-Ice Advanced Settings

**Lock Strength:** Set at 0 and do not adjust.  
**Lock Increment:** SpreadSmart Rx PWM response increment. Set at 70 (no units). Increasing value causes spreader to attempt to correct more frequently causing display to be more jumpy.  
**Update Laps:** Feedback adjustment response cycle rate. Allows coil to react. Set at 3 cycles. Increasing value makes controller respond more slowly, decreasing makes controller respond more rapidly.  
**Unseat Drive Percent:** % of trim signal used to unseat valve at motion startup. Set at 50% (to unseat sticky valves);  
**Unseat Time:** Length of time that unseat signal is sent. Set at 10 (1 equals one tenth of second).

**Speedometer Calibration – part of “Trim/Cal Menu”**

**Speedo Setting:** Pulses Per Mile traveled. Value determined during Speedo Trim step.

**Appendix A: System Drawings**

***Appendix B: Spare parts list***

030169	SpreadSmart Rx LCD Display assembly in housing
030192	SpreadSmart Rx VFD Display assembly in housing
0301925	SS Rx 7” Color TFT Display assembly in housing
0301925T	SS Rx 7” Color TFT Touch Version Display assembly in housing
0301928	SS Rx 10” Color TFT Touch Version Display-Dual Camera Ready Assembly
020284	15’ Cable for Mini Tiger TFT Color display (all sizes)
020283	15’ Cable for Mini Tiger LCD display
TS-3001	5v power cable for Drive by Download bridge (truck mount)
030193	SpreadSmart Rx Mini CPU in Red Housing (Xtec box)
022054	SpreadSmart Rx Mini Switch Panel (stand alone - no housing)
0205086	Switch panel cable (10 foot length) M12 to M12
000453	Replacement 3 volt battery
10117	On / Off Switch - solder attachment only
10118	Toggle Switch - solder attachment only
MK-1003	Main Power Cable
TS-2004	Speedo and Remote Blast/Pass (Pause) Cable
TS-2004E	Speedo Enclosure Series Cable (12ft)

***Appendix D – Typical Frequency Settings by Valve Mfg***

Brand Valve (prewet systems)	100 Hz
Husco – Section Valves –	100 Hz
<b>HydraForce (Cirrus manifold)-</b>	<b>220 Hz</b>
Parker -	60 Hz
Rexroth (MP18)	180 Hz
<b>Sauer Dan Foss - PVG32</b>	<b>80 Hz</b>



## Appendix E – Anti-Ice Flow and Boom Arrangement

### Flow Rates and Volume Dispensed with various booms

Rev C 12/09

**Gallon per Mile (Gal/Mi)**

(also applies to Metric Units)

Flow rate multiplied by # of booms turned on

**3 Booms arranged to cover 3 lanes**

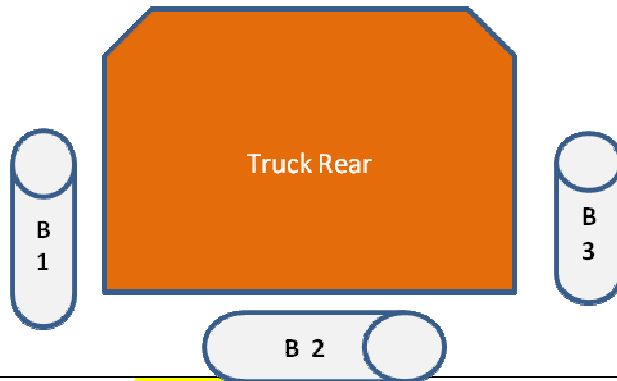

# of Booms On	Rate in Gal. per mile	Miles Driven	Total Gallons Spread	Gallons Per lane mile	Gallons per boom per mile
1	10	1	10	10	10
2			20	10	10
3			30	10	10

**3 Booms inside truck body - 3 booms spread within one lane width**

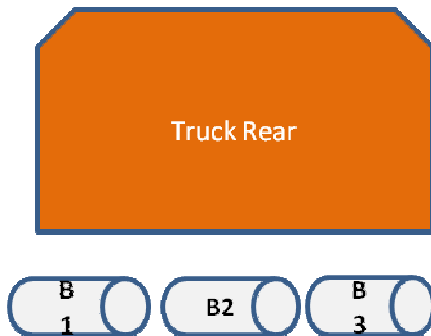

# of Booms On	Rate in Gal. per mile	Miles Driven	Total Gallons Spread	Gallons Per lane mile	Gallons per boom per mile
1	10	1	10	10	10
2			20	20	10
3			30	30	10



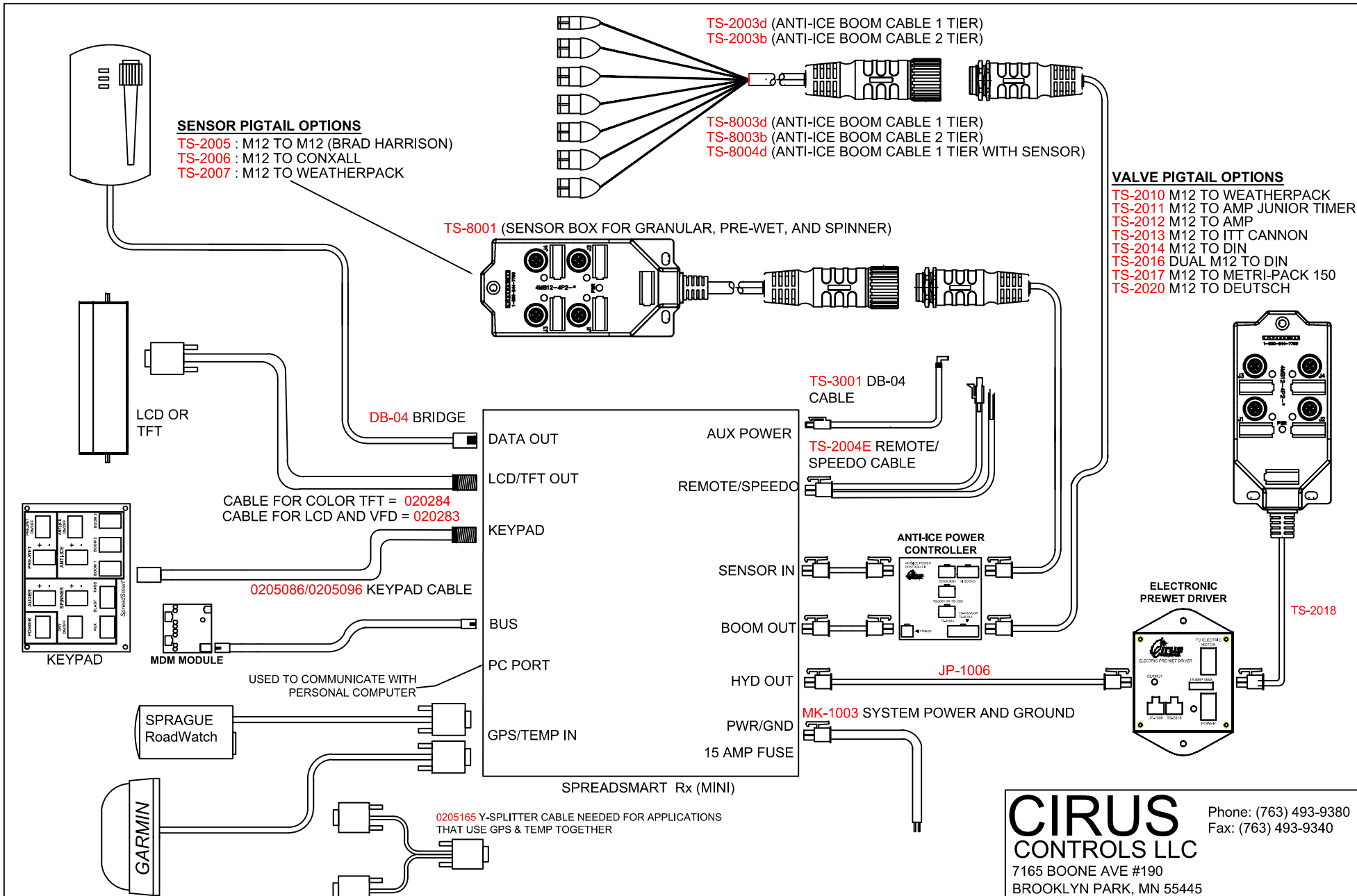

**SENSOR PIGTAIL OPTIONS**  
 TS-2005 : M12 TO M12 (BRAD HARRISON)  
 TS-2006 : M12 TO CONXALL  
 TS-2007 : M12 TO WEATHERPACK

TS-2003d (ANTI-ICE BOOM CABLE 1 TIER)  
 TS-2003b (ANTI-ICE BOOM CABLE 2 TIER)

TS-8003d (ANTI-ICE BOOM CABLE 1 TIER)  
 TS-8003b (ANTI-ICE BOOM CABLE 2 TIER)  
 TS-8004d (ANTI-ICE BOOM CABLE 1 TIER WITH SENSOR)

**VALVE PIGTAIL OPTIONS**  
 TS-2010 M12 TO WEATHERPACK  
 TS-2011 M12 TO AMP JUNIOR TIMER  
 TS-2012 M12 TO AMP  
 TS-2013 M12 TO ITT CANNON  
 TS-2014 M12 TO DIN  
 TS-2016 DUAL M12 TO DIN  
 TS-2017 M12 TO METRI-PACK 150  
 TS-2020 M12 TO DEUTSCH

TS-8001 (SENSOR BOX FOR GRANULAR, PRE-WET, AND SPINNER)

DB-04 BRIDGE

TS-3001 DB-04 CABLE

TS-2004E REMOTE/SPEEDO CABLE

CABLE FOR COLOR TFT = 020284  
 CABLE FOR LCD AND VFD = 020283

0205086/0205096 KEYPAD CABLE

ANTH-ICE POWER CONTROLLER

ELECTRONIC PREWET DRIVER

JP-1006

MK-1003 SYSTEM POWER AND GROUND

TS-2018

USED TO COMMUNICATE WITH PERSONAL COMPUTER

SPREADSMART Rx (MINI)

0205165 Y-SPLITTER CABLE NEEDED FOR APPLICATIONS THAT USE GPS & TEMP TOGETHER

**CIRUS CONTROLS LLC**  
 7165 BOONE AVE #190  
 BROOKLYN PARK, MN 55445

Phone: (763) 493-9380  
 Fax: (763) 493-9340

SPREAD SMART RX (MINI)

CABLE OVERVIEW

THIS DRAWING IS THE PROPERTY OF CIRUS CONTROLS. THIS IS TO BE CONSIDERED CONFIDENTIAL AND PROPRIETARY NO REPRODUCTION IN WHOLE OR PART WITH OUT PERMISSION IS ALLOWED.

REV	DATE	DESCRIPTION
A	5-11-12	UPDATED PARTS AND REALIGNED (RG)
B	8-20-12	ADDED MDM, EPWD, AND AI PWR CNTRLR
C	-	-
D	-	-
E	-	-

DESIGN: JTM	DRAWN: JTM	AS BUILT: -
-------------	------------	-------------

PROJECT NUMBER: TSCOM-OV	SCALE: NONE	DATE: 8-20-12	REV. B
		SHT 1 OF 1	

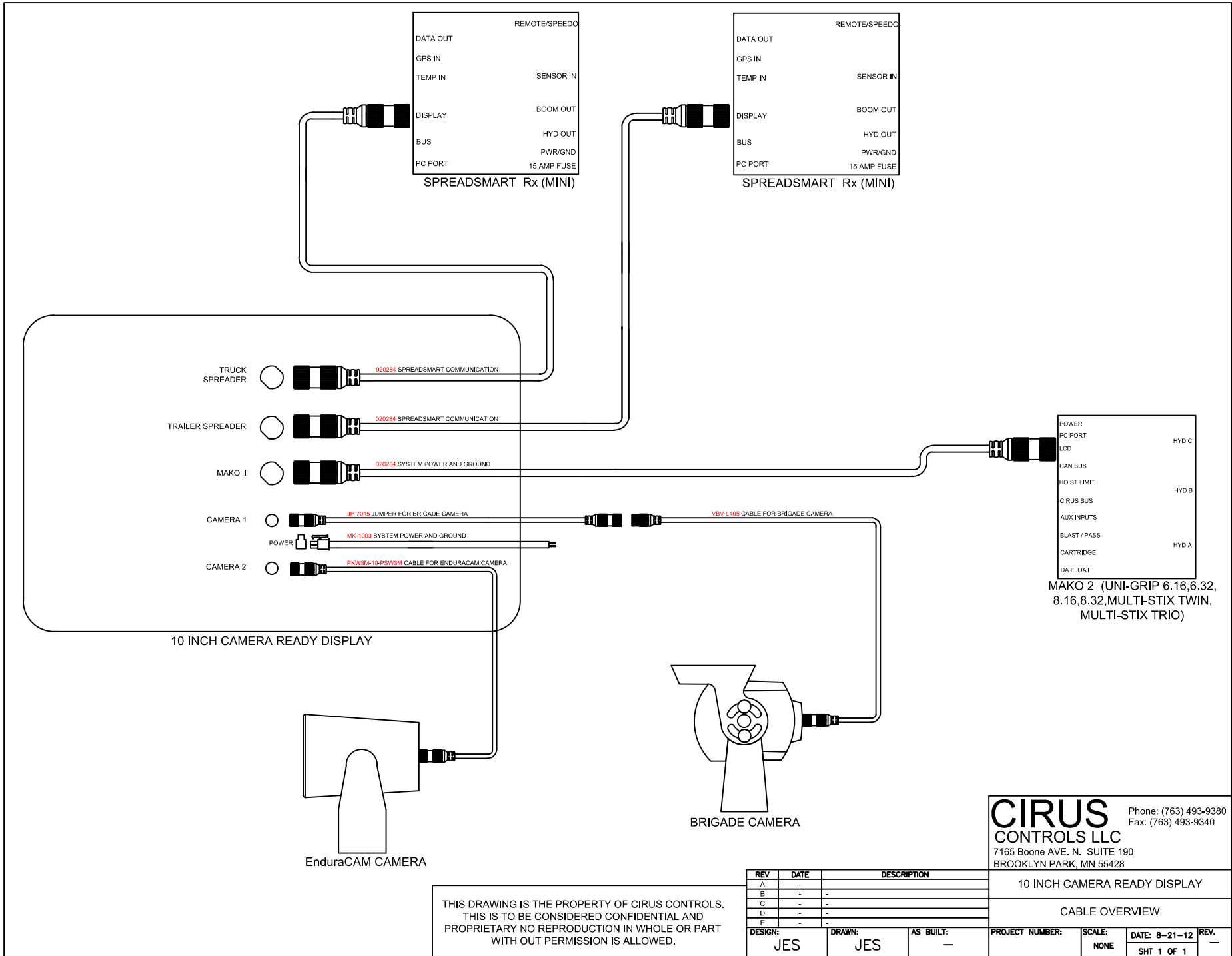

THIS DRAWING IS THE PROPERTY OF CIRUS CONTROLS.  
 THIS IS TO BE CONSIDERED CONFIDENTIAL AND  
 PROPRIETARY NO REPRODUCTION IN WHOLE OR PART  
 WITH OUT PERMISSION IS ALLOWED.

REV	DATE	DESCRIPTION
A	-	
B	-	
C	-	
D	-	
E	-	

DESIGN:	DRAWN:	AS BUILT:	PROJECT NUMBER:	SCALE:	DATE:	REV.
JES	JES	-		NONE	8-21-12	-
					SHT 1 OF 1	

**CIRUS**  
 CONTROLS LLC  
 7165 Boone AVE. N. SUITE 190  
 BROOKLYN PARK, MN 55428  
 Phone: (763) 493-9380  
 Fax: (763) 493-9340

10 INCH CAMERA READY DISPLAY

CABLE OVERVIEW

### Cable Applications

Proper management of cabling systems can mean the difference between a dependable and smooth operating installation and costly reoccurring down time. The suggestions outlined below illustrate some of the common sources of problems and provide simple and effective solutions.

### Proper Bend Radius for Fixed and Moving Applications

Providing sufficient bend radius will allow the cable to absorb the energy of bending over a greater portion of its length, increasing its effective working life. Small increases in the radius of the bend can produce substantial increases in cable life.

Fixed Applications:  
Minimum bend radius 5x cable diameter

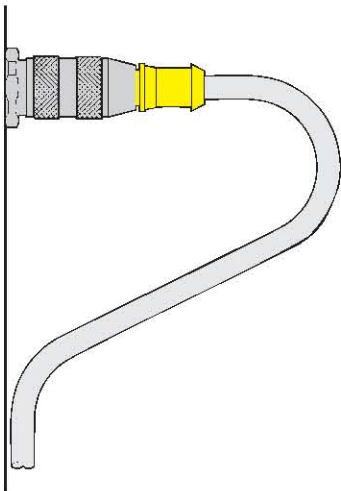

Moving Applications:  
Minimum bend radius 10x cable diameter

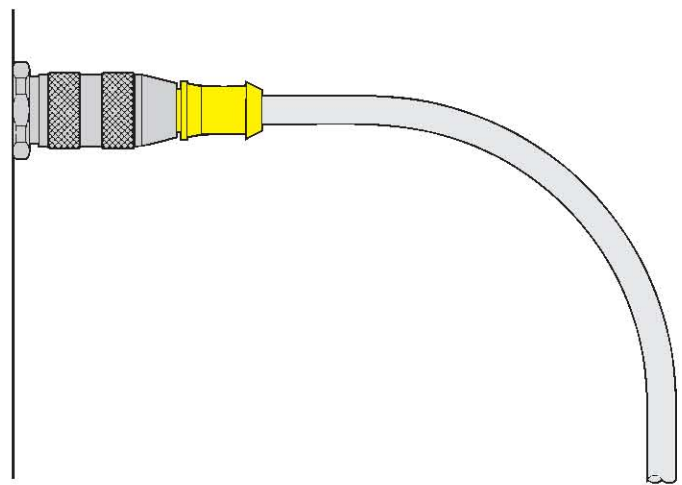

### Eliminating Stress Points in Cable Dress

Installing cables to allow for adequate stress loops and freedom of motion increase the life of the cables. **TURCK** cordsets incorporate molded strain reliefs that will assist in preventing stress.

Tie Down Loops

Correct

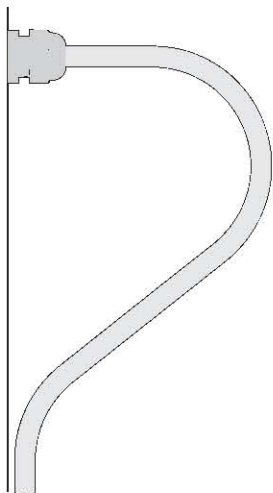

Incorrect

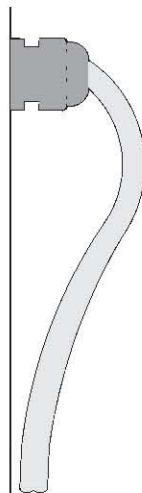

Strain Relief

Correct

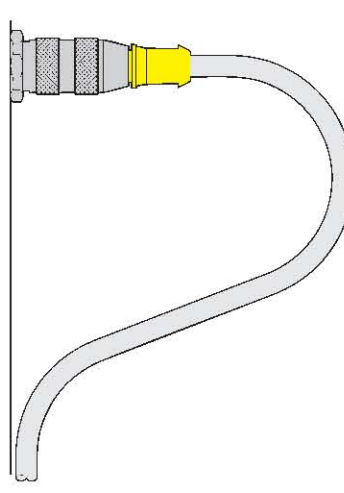

Incorrect

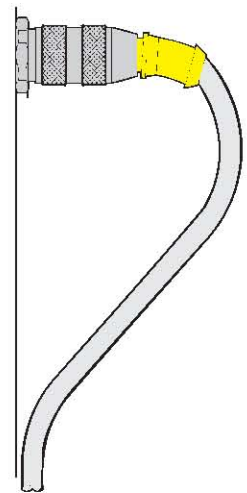

## Cable Bundling Techniques

When bundling several cables together, always keep the bundle loose enough to move within itself. Tightly tied bundles create both compression and tension stresses when the bundle is moved.

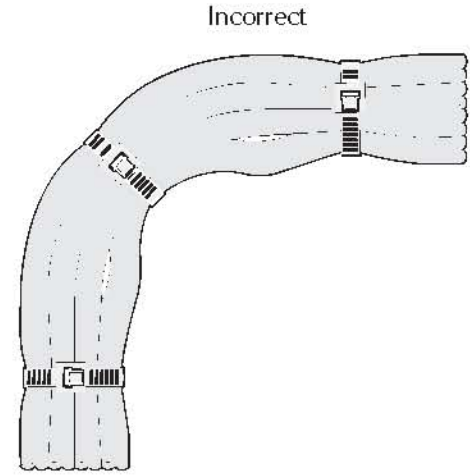
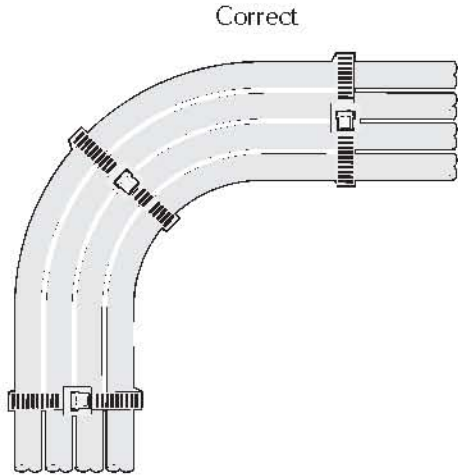

## Cabling for Motion Applications

Where cabling is subjected to linear, angular or rotational motion between two points, always allow adequate cable length to absorb the energy imparted by the motion. Use of coiled cords, mechanical support mechanisms, or large, well supported cable loops will maximize cable life.

Coil Cord



"C" Track

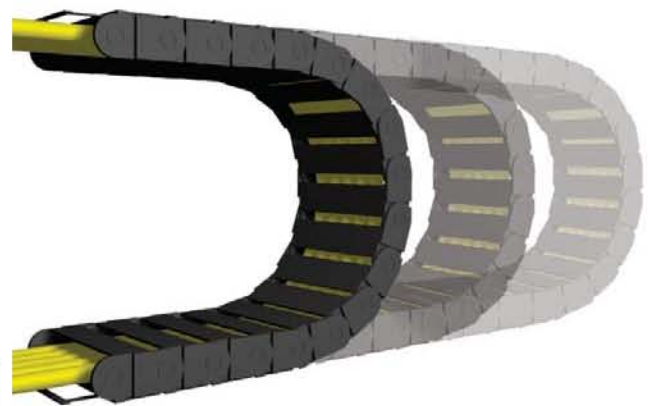

Cable Loop

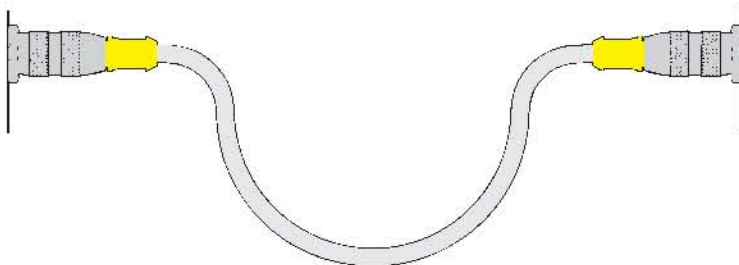

## Tying Cables with Cable Ties

When tying cable with self locking cable ties, always leave the ties loose enough for the cables to slide freely under the tie. Over tightening will create stress concentrations that can cause the conductors to fail prematurely. Never tighten the tie to the point where the cable jacket becomes deformed or pinched.

Correct

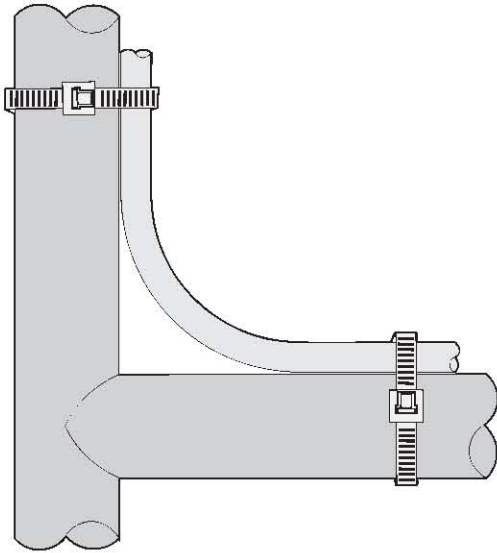

Incorrect

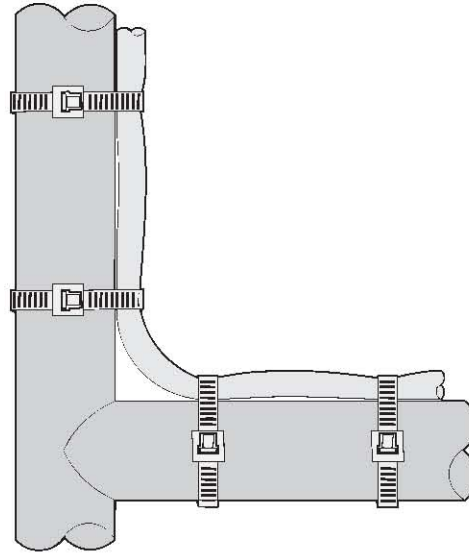

**Note:** Do not use tools to tighten coupling nut. Hand-tighten only!!

# B.O.M.

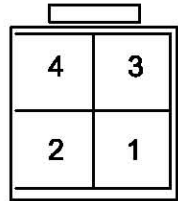

**BACK VIEW  
(SIDE PINS ARE INSERTED FROM)**

MOLEX PIN#	SIGNAL
1	GROUND : WHITE (18AWG)
2	+12 VDC : RED (18AWG)
3	GROUND : WHITE (18AWG)
4	+12 VDC : RED (18AWG)

QTY	PART NUMBER	DESCRIPTION
1	39-01-2040 (Digi-Key WM3701-ND)	MOLEX RECEPTACLE 4 PIN
4	39-00-0039 (Digi-Key WM2501-ND)	MOLEX TERMINALS FEMALE 18-24 AWG
15 FT	LCP-250	.250" SPLIT LOOM

**NOTES:**

1. LABEL WIRES WITH SIGNAL EVERY 12 INCHES
2. TAPE SPLIT LOOM EVERY 12 INCHES

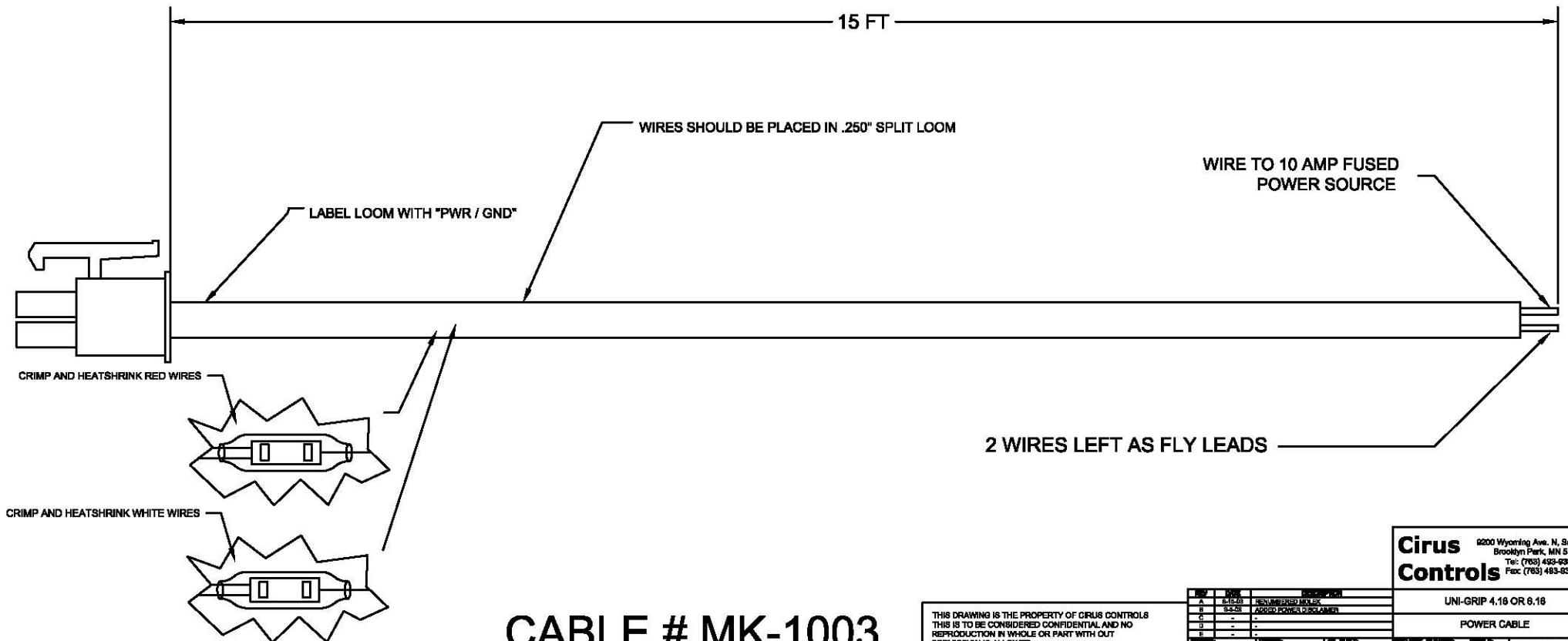

**CABLE # MK-1003**

THIS DRAWING IS THE PROPERTY OF CIRUS CONTROLS  
THIS IS TO BE CONSIDERED CONFIDENTIAL AND NO  
REPRODUCTION IN WHOLE OR PART WITH OUT  
PERMISSION IS ALLOWED.

REV	DATE	DESCRIPTION	CIRUS CONTROLS		
A	8-16-03	RENUMBERED MOLEX	UNI-GRIP 4,16 OR 6,18		
B	8-28-03	ADD'D POWER DISCLAIMER	POWER CABLE		
C	-	-	DESIGN	DATE	REV
D	-	-	JTM	7-7-03	1
E	-	-	JTM	WORK	B
PROJECT NUMBER			SHEET 1 OF 1		
MK-1003			8/1		

**Cirus Controls**  
9200 Wyoming Ave. N. Suite 320  
Brooklyn Park, MN 55445  
Tel: (763) 493-8990  
Fax: (763) 493-8940



**NOTES:**

- 1) EACH CABLE TO BE BAGGED IN LABELLED BAG MARKED "TS-3001"
- 2) LABEL CABLE AS INDICATED
- 3) ADDITIONAL INSTRUCTIONS CABLE GUAGES FOR CIRUS INTERNAL USE ONLY

**B.O.M.**

<u>ITEM</u>	<u>QTY</u>	<u>PART NUMBER</u>	<u>DESCRIPTION</u>
1	1	39-01-4030	3 PIN MOLEX MINI-FIT JR. PLUG
2	2	39-00-0039	MINI-FIT JR. PLUG SOCKET
3	1	CUI - CA-2198	RIGHT ANGLE DC POWER PLUG 1.7/4.0mm

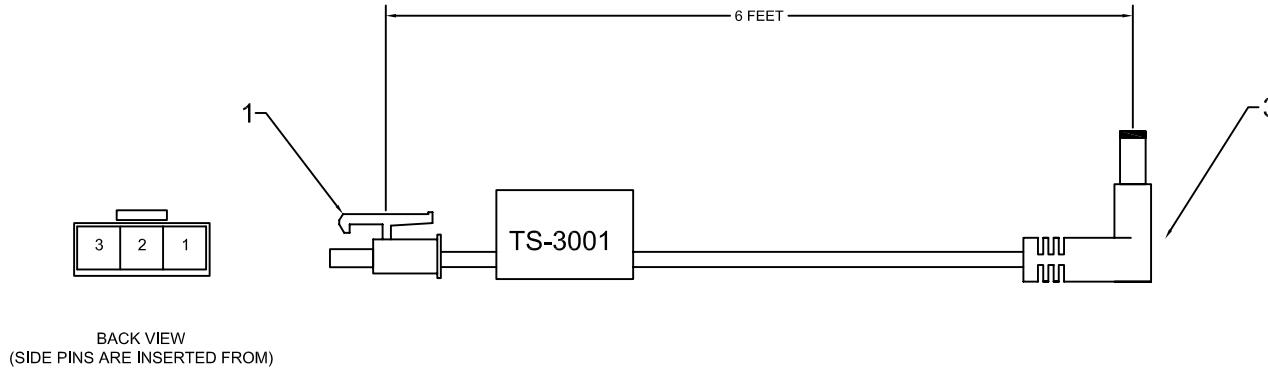

<u>SOCKET NO</u>	<u>COLOR</u>	<u>SIGNAL NAME</u>	<u>GAUGE</u>	<u>PIN NO</u>
1	BLACK	GROUND	18	BARREL
2	BLK/WHT	+5V DC	18	PIN

DUE TO VARIOUS WALL WART CABLES WITH THE DWL-G820 BRIDGE "CIRUS PERSONAL" FOLLOW THE BELOW WIRING SCHEME

THINNER GUAGE WIRE (20 AWG OR 22AWG)	THICKER GUAGE WIRE (16 AWG OR 18AWG)
ALL BLACK WIRE MOUNT INTO PIN-1	ALL BLACK WIRE MOUNT INTO PIN-1
WHITE TEXTED WIRE MOUNT INTO PIN-2	WHITE TEXTED WIRE MOUNT INTO PIN-2

CABLE #TS-3001

THIS DRAWING IS THE PROPERTY OF CIRUS CONTROLS. THIS IS TO BE CONSIDERED CONFIDENTIAL AND PROPRIETARY NO REPRODUCTION IN WHOLE OR PART WITH OUT PERMISSION IS ALLOWED.

**CIRUS** Phone: (763) 493-9380  
**CONTROLS LLC** Fax: (763) 493-9340  
 9210 WYOMING AVE. N. SUITE 200  
 BROOKLYN PARK, MN 55445

REV	DATE	DESCRIPTION	PROJECT NUMBER:	SCALE:	DATE:	REV.
A	11-01-07	INHUSE WIRING INSTRUCTIONS RG	TS-3001	NONE	5-19-09	B
B	5-19-09	-change to small dia power plug (old is ca-2191) RG				
C	-	-				
D	-	-				
E	-	-				
DESIGN: MVM      DRAWN: MVM      AS BUILT: -			TS-3001	NONE	5-19-09	B
					SHT 1 OF 1	

SPREADER CABLE SYSTEM

BRIDGE POWER CABLE

# CABLE # MK-3002

# B.O.M.

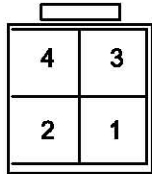

MOLEX PIN#	SIGNAL
1	GROUND : WHITE (18AWG)
2	+12 VDC : RED (18AWG)
3	GROUND : WHITE (18AWG)
4	+12 VDC : RED (18AWG)

QTY	PART NUMBER	DESCRIPTION
2	39-01-2040 (Digi-Key WM3701-ND)	MOLEX RECEPTACLE 4 PIN
8	39-00-0039 (Digi-Key WM2501-ND)	MOLEX TERMINALS FEMALE 18-24 AWG
15-1/2 FT	LCP-250	.250" SPLIT LOOM

BACK VIEW  
(SIDE PINS ARE INSERTED FROM)

**NOTES:**

1. LABEL WIRES WITH SIGNAL EVERY 12 INCHES
2. TAPE SPLIT LOOM EVERY 12 INCHES

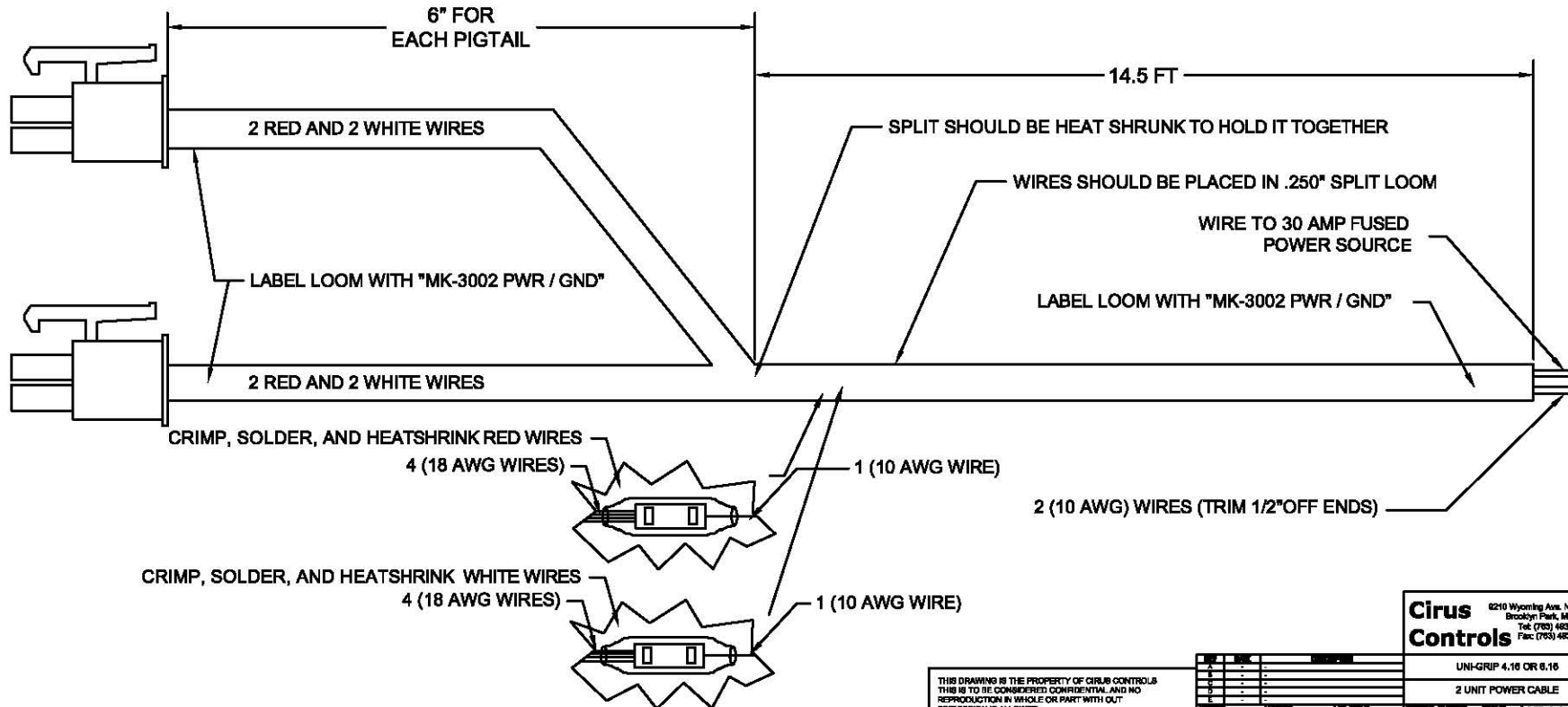

**Cirus Controls**  
 6210 Wyoming Ave., N. Suite 200  
 Brooklyn Park, MN 55446  
 Tel: (763) 483-9350  
 Fax: (763) 483-9340

THIS DRAWING IS THE PROPERTY OF CIRUS CONTROLS  
 THIS IS TO BE CONSIDERED CONFIDENTIAL AND NO  
 REPRODUCTION IN WHOLE OR PART WITH OUT  
 PERMISSION IS ALLOWED.

REV	DATE	BY	CHKD	DESCRIPTION
1		JTM	JTM	UNI-GRIP 4,16 OR 6,16
2				2 UNIT POWER CABLE
3				
4				
5				
6				
7				
8				
9				
10				

**Notes:**

1) Each cable to be bagged and labelled.

**BILL OF MATERIALS**

OUR #	PART #	QTY	DESCRIPTION
-	RSC 4.5T-5/CS...	1	5 PIN MALE M12 18 AWG CORDSET-5M
000361	DE08PDUCD1	1	DB9 MALE SOLDERABLE
000360	NORCOMP 993-009-010R031	1	DB9 BACKSHELL w/THUMBSCREWS

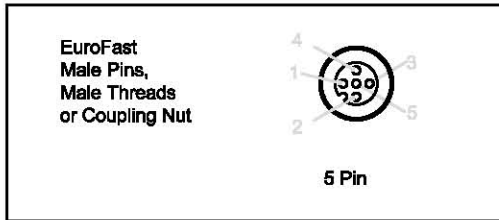

M12 PIN	COLOR	SIGNAL NAME	DB9 PIN
1	RED	GROUND	5
2	RED/WHITE	12V POWER	4
3	RED/BLACK	5V POWER	9
4	RED/YELLOW	TX	3
5	GREEN	RX	2

DB9 MALE END



Label each cable

**Cable #020283 (C1001-LCD)**

Label each cable

THIS DRAWING IS THE PROPERTY OF CIRUS CONTROLS. THIS IS TO BE CONSIDERED CONFIDENTIAL AND PROPRIETARY. NO REPRODUCTION IN WHOLE OR PART WITH OUT PERMISSION IS ALLOWED.

REV	DATE	DESCRIPTION
A	02-21-08	Updated colors for custom wire
B	7-16-08	added label for both sides
C	-	-
D	-	-
E	-	-
F	-	-
G	-	-
H	-	-
-	-	-
-	-	-

DESIGN: MVM	DRAWN: MVM	AS BUILT: -
-------------	------------	-------------

**CIRUS CONTROLS LLC**  
 Phone: (763) 493-9380  
 Fax: (763) 493-9340  
 9200 WYOMING AVE. N. SUITE 370  
 BROOKLYN PARK, MN 55445

**MINI TIGER SHARK**

LCD/WFD CABLE FOR DISPLAY

PROJECT NUMBER: C1001-LCD	SCALE: NONE	DATE: 07-16-08	REV: B
		SHT 1 OF 1	

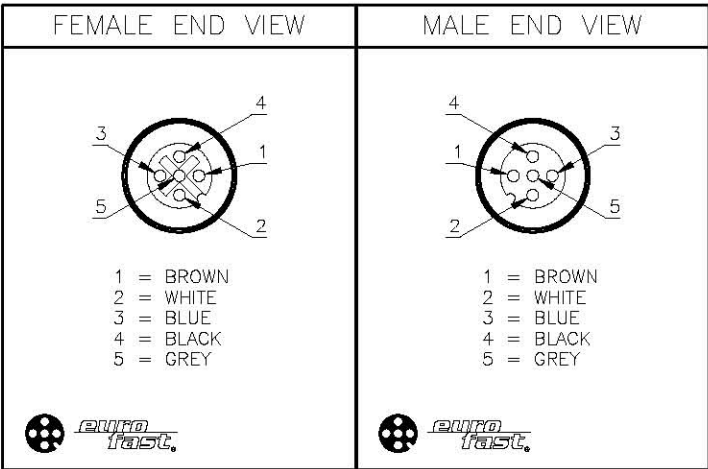

SPECIFICATIONS	
CONTACT CARRIER MATERIAL	NYLON or PUR
MOLDED HEAD MATERIAL/COLOR	THERMOPLASTIC PUR/YELLOW
CONTACT MATERIAL/PLATING	BRASS/GOLD
COUPLING NUT MATERIAL/PLATING	BRASS/NICKEL
RATED CURRENT [A]	4.0 A
RATED VOLTAGE [V]	250 V
OUTER JACKET MATERIAL/COLOR	PVC/GREY
CONDUCTOR INSULATION MATERIAL	PVC
NUMBER OF CONDUCTORS [AWG]	5x22 AWG
TEMPERATURE RANGE	-40°C to +105°C (-40°F to +221°F)
PROTECTION CLASS	MEETS NEMA 1,3,4,6P AND IEC IP68

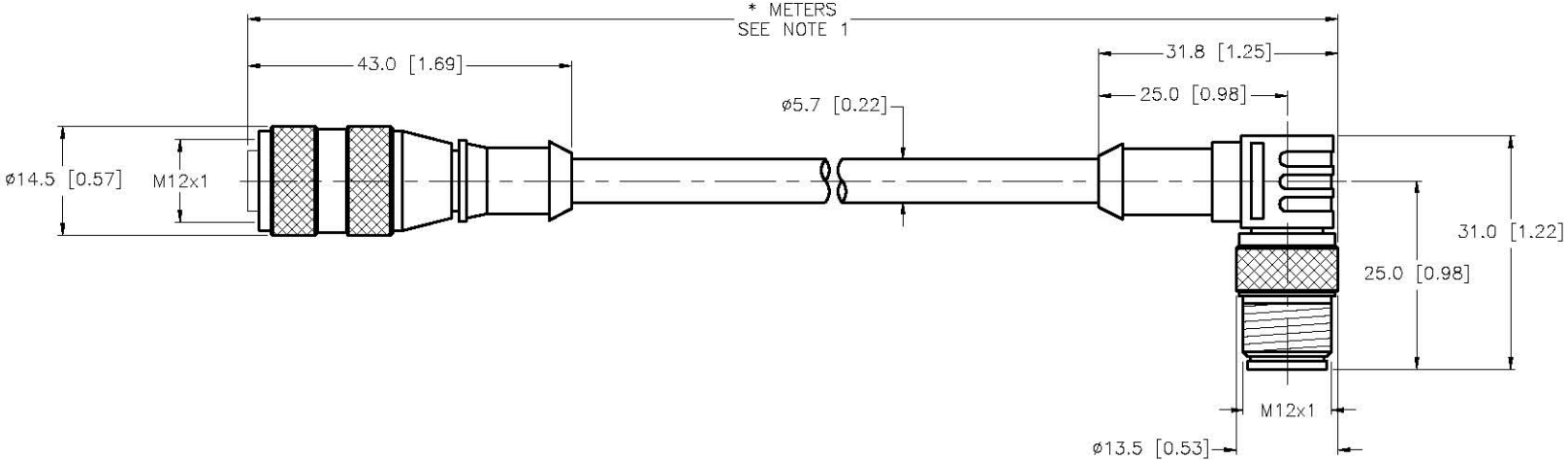

CABLE LENGTH	TOLERANCE
ALL LENGTHS	+ 4% (OR 50mm) OF LENGTH - 0% (OR 0mm) OF LENGTH WHICHEVER IS GREATER
STRIP LENGTH	TOLERANCE
0-7mm	±0.5mm
8-29mm	±1.0mm
30-49mm	±2.0mm
50-69mm	±3.0mm
70-100mm	±4.0mm
OVER 100mm	±5.0mm

SOURCE DRAWING - FOR REFERENCE ONLY

NOTES:  
1. "\*" INDICATES CABLE LENGTH IN METERS. CONTACT TURCK TO ORDER SPECIFIC LENGTHS.

RELATED DOCUMENTS	3RD ANGLE PROJECTION	THIS DRAWING IS PROPERTY OF TURCK INC. USE OF THIS DOCUMENT WITHOUT WRITTEN PERMISSION IS PROHIBITED.	<b>TURCK INC</b> High Technology Sensors and Automation Controls 3000 CAMPUS DRIVE MINNEAPOLIS, MN 55441 1-800-544-7789 (763) 553-7300 (763) 553-0708 fax turck.com	
1.		DRFT	DATE 09/06/00	DESCRIPTION RK 4.5T-*--WS 4.5T
2.		JB	SCALE 1=1	
3.	TOLERANCES UNLESS OTHERWISE SPECIFIED 0.5 TO 6 ±0.1 6 TO 30 ±0.2 30 TO 200 ±0.3 OVER 200 ±0.4 ANGLES ±1° ALL INCH DIMENSIONS ARE REFERENCE ONLY	DSGN	UNIT OF MEASUREMENT <b>MLLIMETER [ INCH ]</b>	IDENTIFICATION NO.
4.		SEE SPECIFICATIONS	DO NOT SCALE THIS DRAWING	REV C
MATERIAL	SEE SPECIFICATIONS	FILE: EURO-C/777000631	SHEET 1 OF 1	
FINISH	SEE SPECIFICATIONS			

**B.O.M.**

**NOTES:**

1. PLUGS FOR UNUSED PORTS:  
PN# VZ-3
2. TIE GROUND AND COMMON TOGETHER AT LEAST  
2 INCHES FROM CONNECTOR

ITEM	QTY	PART NUMBER	DESCRIPTION
1	1	4MB12-4P2-12	VALVE BOX W/ CABLE (TURCK)
2	1	39-01-2060	MOLEX 6 PIN
3	6	39-00-0039	MOLEX TERMINALS 18-24 AWG

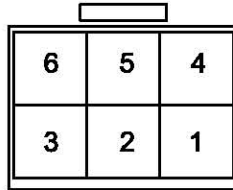

**BACK VIEW**  
(SIDE PINS ARE INSERTED FROM)

**MOLEX PIN# SIGNAL**

- 1 GROUND : GREEN/YELLOW
- 2 ANTI-ICE SENSOR : GRAY
- 3 SPINNER SENSOR : GREEN
- 4 POWER (5 VDC OR 12 VDC) : BROWN
- 5 PRE-WET SENSOR : YELLOW
- 6 AUGER SENSOR : WHITE

COM: BLUE (NOTE 3)

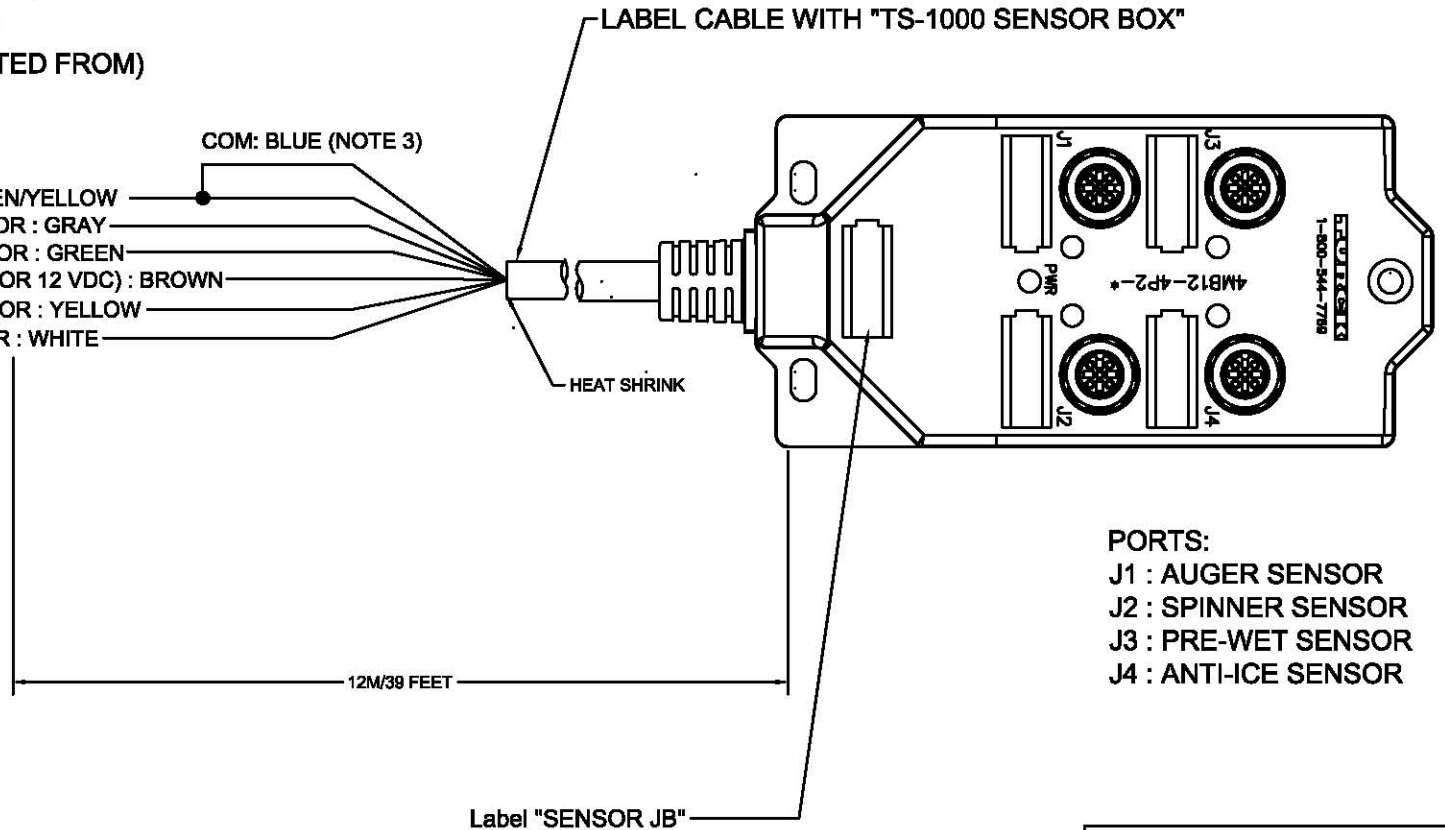

- PORTS:**
- J1 : AUGER SENSOR
  - J2 : SPINNER SENSOR
  - J3 : PRE-WET SENSOR
  - J4 : ANTI-ICE SENSOR

**CIRUS** Phone: (763) 493-9380  
**CONTROLS LLC** Fax: (763) 493-9340  
 9210 WYOMING AVE. N. SUITE 200  
 BROOKLYN PARK, MN 55445

THIS DRAWING IS THE PROPERTY OF CIRUS CONTROLS.  
 THIS IS TO BE CONSIDERED CONFIDENTIAL AND  
 PROPRIETARY NO REPRODUCTION IN WHOLE OR PART  
 WITH OUT PERMISSION IS ALLOWED.

REV	DATE	DESCRIPTION
A	-	-
B	-	-
C	-	-
D	-	-
E	-	-

DESIGN: MVM DRAWN: MVM AS BUILT: -

SPREADER CABLE SYSTEM			
SENSOR BOX			
PROJECT NUMBER:	SCALE:	DATE:	REV:
TS-1000	NONE	7-28-08	-
SHT 1 OF 1			

# B.O.M.

## NOTES:

- PLUGS FOR UNUSED PORTS:  
PN# VZ-3
- TIE GROUND AND COMMON TOGETHER AT LEAST  
2 INCHES FROM CONNECTOR

ITEM	QTY	PART NUMBER	DESCRIPTION
1	1	4MB12-4P2-5	VALVE BOX W/ CABLE (TURCK)
2	1	39-01-2060	MOLEX 6 PIN
3	6	39-00-0039	MOLEX TERMINALS 18-24 AWG

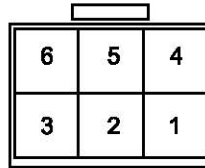

BACK VIEW  
(SIDE PINS ARE INSERTED FROM)

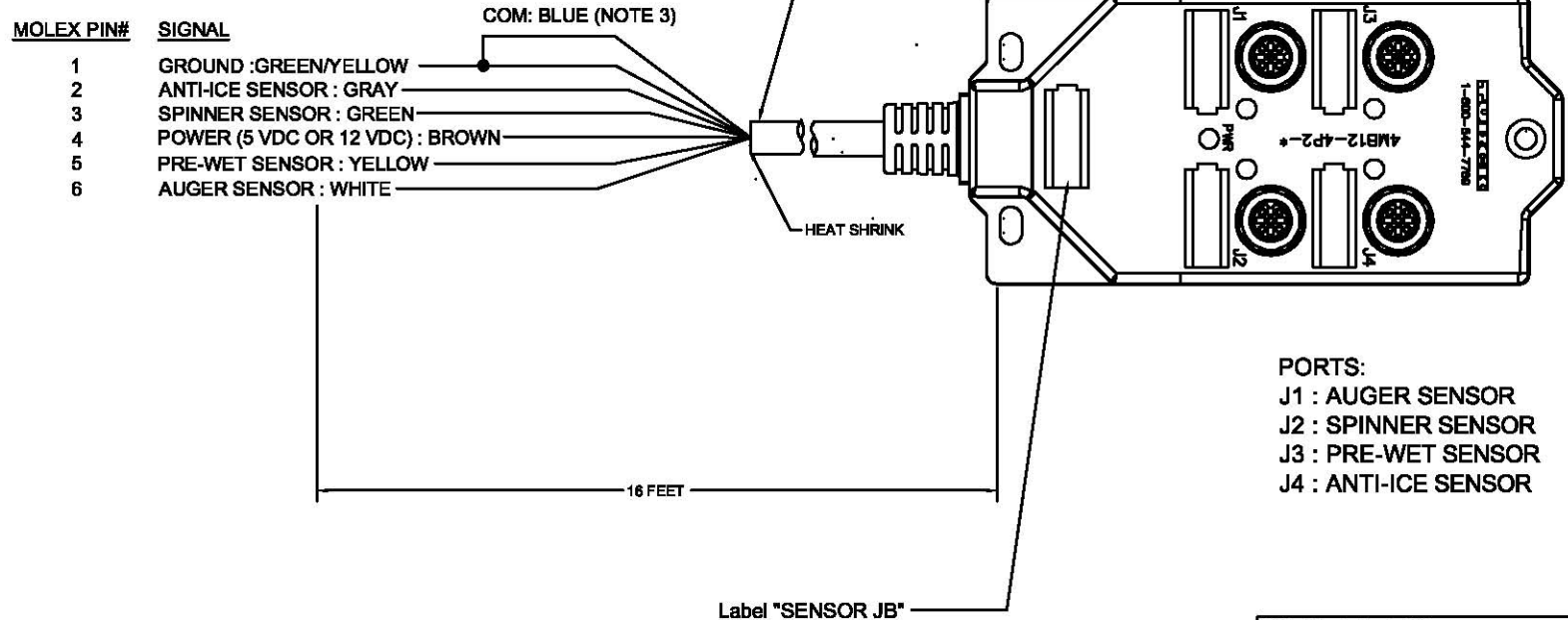

**CIRUS**  
**CONTROLS LLC**  
 9210 WYOMING AVE. N. SUITE 200  
 BROOKLYN PARK, MN 55445  
 Phone: (763) 493-9380  
 Fax: (763) 493-8340

THIS DRAWING IS THE PROPERTY OF CIRUS CONTROLS.  
 THIS IS TO BE CONSIDERED CONFIDENTIAL AND  
 PROPRIETARY NO REPRODUCTION IN WHOLE OR PART  
 WITH OUT PERMISSION IS ALLOWED.

REV	DATE	DESCRIPTION	DESIGN	DRAWING	AS BUILT	PROJECT NUMBER	SCALE	DATE	REV.
A	-	-	MVM	MVM	-	TS-1000-M5	NONE	12-22-08	-
B	-	-							
C	-	-							
D	-	-							
E	-	-							

SPREADER CABLE SYSTEM

SENSOR BOX

SHT 1 OF 1

# B.O.M.

## NOTES:

1. CABLE TO BE BAGGED AND THE BAG LABELED WITH "TS-2004"

QTY	PART NUMBER	DESCRIPTION
1	39-01-2040 (Digi-Key WM3701-ND)	MOLEX RECEPTACLE 4 PIN
4	39-00-0039 (Digi-Key WM2501-ND)	MOLEX TERMINALS FEMALE 18-24 AWG
12 FT	AUTOMOTIVE GRADE	2 CONDUCTOR 18 AWG CABLE
1	12010973	2-PIN WEATHER PACK (SHROUD)
2	12089040	PINS FOR WEATHER PACK
2	12015323	SEAL FOR WEATHER PACK

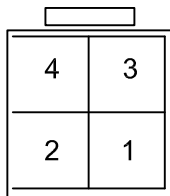
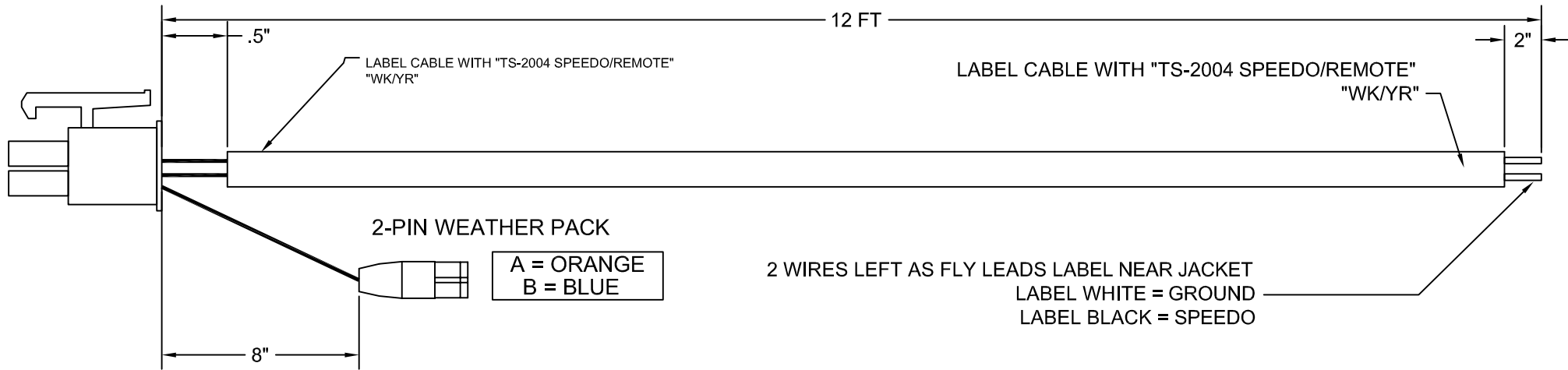

MOLEX PIN#	SIGNAL
1	GROUND : WHITE (18AWG)
2	REMOTE PASS (PAUSE) : BLUE
3	SPEEDO : GREEN OR BLACK
4	REMOTE BLAST (MORAY = REMOTE TRIGGER) : ORANGE

BACK VIEW  
(SIDE PINS ARE INSERTED FROM)

THIS DRAWING IS THE PROPERTY OF CIRUS CONTROLS  
THIS IS TO BE CONSIDERED CONFIDENTIAL AND NO  
REPRODUCTION IN WHOLE OR PART WITH OUT  
PERMISSION IS ALLOWED.

REV	DATE	DESCRIPTION
A	4-20-07	LABELLED OTHER END OF CABLE
B	4-26-07	CHANGES TO CABLE
C	12-8-09	ADDED MORAY TRIGGER
D	10-2-10	ADDED THE WORD 'PAUSE' AFTER 'PASS'
E	-	-

DESIGN: JTM	DRAWN: JTM	AS BUILT: -	PROJECT NUMBER: TS-2004	SCALE: NONE	DATE: 12-8-09	REV. C
			SHT 1 OF 1			

**Cirrus Controls**  
9200 Wyoming Ave. N. Suite 320  
Brooklyn Park, MN 55445  
Tel: (763) 493-9380  
Fax: (763) 493-9340

SPREADER CABLE SYSTEM  
SPEEDO AND REMOTE BLAST/PASS

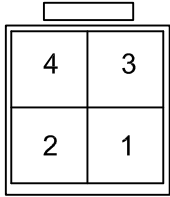

BACK VIEW  
(SIDE PINS ARE INSERTED FROM)

MOLEX PIN#	SIGNAL
1	GROUND : WHITE (18AWG)
2	REMOTE PASS (PAUSE) : BLUE
3	SPEEDO : BLACK
4	REMOTE BLAST (MORAY = REMOTE TRIGGER) : ORANGE

# B.O.M.

QTY	PART NUMBER	DESCRIPTION
1	39-01-2040 (Digi-Key WM3701-ND)	MOLEX RECEPTACLE 4 PIN
2	39-00-0039 (Digi-Key WM2501-ND)	MOLEX TERMINALS FEMALE 18-24 AWG
12 FT	AUTOMOTIVE GRADE	2 CONDUCTOR 18 AWG CABLE

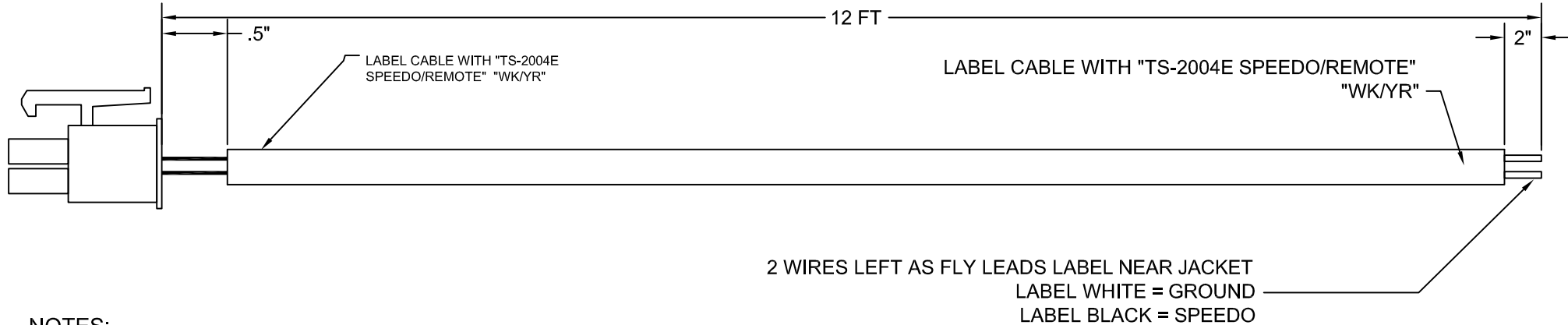

- NOTES:**
1. MOLEX PINS 2 AND 4 ARE POPULATED AT CIRUS (IF USED WITH A PLOW CONTROLLER)

## CABLE # TS-2004E

THIS DRAWING IS THE PROPERTY OF CIRUS CONTROLS  
THIS IS TO BE CONSIDERED CONFIDENTIAL AND NO  
REPRODUCTION IN WHOLE OR PART WITH OUT  
PERMISSION IS ALLOWED.

REV	DATE	DESCRIPTION	SPREADER CABLE SYSTEM		
A	5-10-10	ADDED THE WORD 'PAUSE' AFTER 'PASS'	SPEEDO WITH REMOTE BLAST/PASS INPUT		
B	-	-			
C	-	-			
D	-	-			
E	-	-			
DESIGN:	RLG	DRAWN:	RLG	AS BUILT:	-
PROJECT NUMBER		TS-2004E	SCALE	NONE	DATE: 5-3-11
REV.		-	SHT 1 OF 1		-

**Cirus Controls**  
7165 Boone Ave. N, Suite 190  
Brooklyn Park, MN 55445  
Tel: (763) 493-9380  
Fax: (763) 493-9340



EuroFast  
Female Pins,  
Female Threads  
or Coupling Nut



4-pin



5-pin

EuroFast  
Male Pins,  
Male Threads  
or Coupling Nut



4-pin



5-pin

# B.O.M.

ITEM	QTY	PART NUMBER	DESCRIPTION
1	1	WK 4.5T-1.3-WS 4.5T/S653	M12 90 DEGREE TO M12 90 DEGREE

**NOTES:**

- To specify nylon coupling nut, add "K" to part number.  
For example: WK(S)...to WK(S)K...
- To specify stainless steel coupling nut, add a "V" to part number.  
For example: WK(S)...to WK(S)V...

CABLE (Ø5.2 mm)

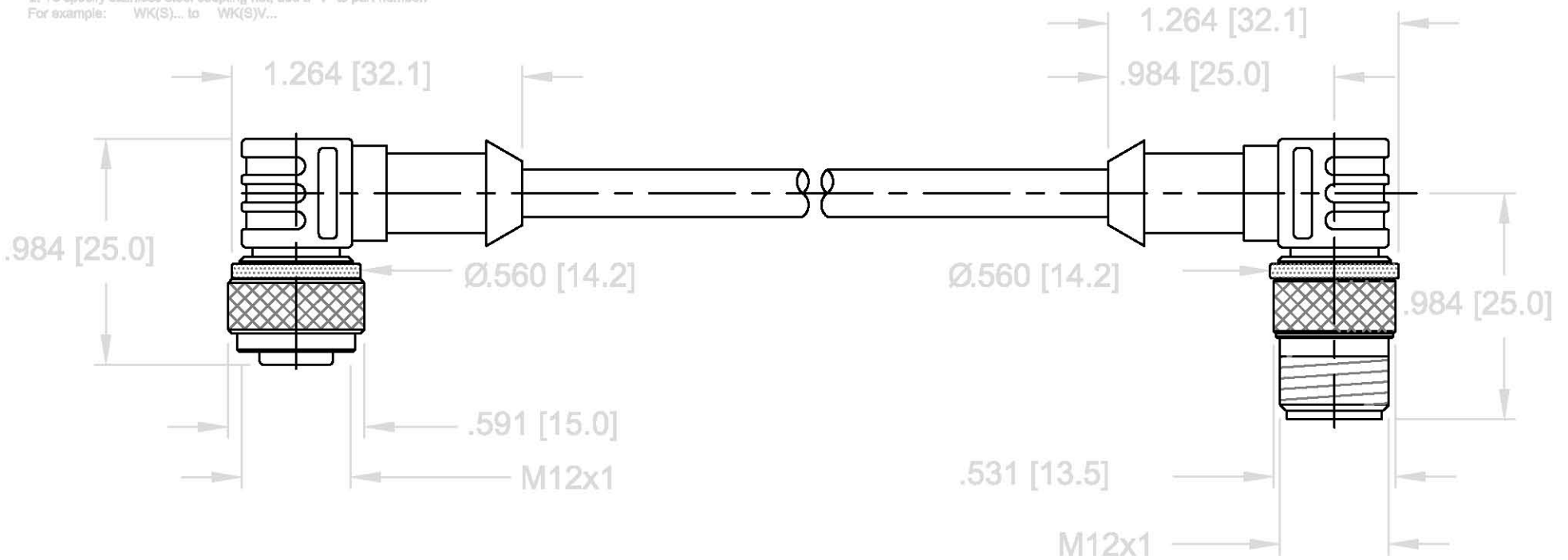

**CIRUS**  
CONTROLS LLC  
9200 WYOMING AVE. N. SUITE 320  
BROOKLYN PARK, MN 55445  
Phone: (763) 493-9380  
Fax: (763) 493-9340

THIS DRAWING IS THE PROPERTY OF CIRUS CONTROLS.  
THIS IS TO BE CONSIDERED CONFIDENTIAL AND  
PROPRIETARY NO REPRODUCTION IN WHOLE OR PART  
WITH OUT PERMISSION IS ALLOWED.

REV	DATE	DESCRIPTION			
A	9-9-03	-	SPREADER CABLE SYSTEM		
B	-	-	M12 TO M12		
C	-	-	DESIGN:	DRAWN:	AS BUILT:
D	-	-	JTM	JTM	-
E	-	-	PROJECT NUMBER:	SCALE:	DATE: 3-30-04
			TS-2005	NONE	SHT 1 OF 1

# B.O.M.

<u>ITEM</u>	<u>QTY</u>	<u>PART NUMBER</u>	<u>CIRUS PN</u>	<u>DESCRIPTION</u>
1	1	????	????	M12 90 degree connector and cable
2	1	3182-3SG-3DC	000624	CONXALL CONNECTOR - 3 SOCKET FEMALE (SHELL & TERMINALS)

<u>M12</u>	<u>GAUGE</u>	<u>LENGTH</u>	<u>SIGNAL</u>	<u>WIRE COLOR</u>	<u>CRIMP END</u>	<u>J3</u>
4	20 AWG	48"	SENSOR SIGNAL	BLACK	INCLUDED	6 O'CLOCK (3)
1	20 AWG	48"	+5 VOLTS FOR SENSOR	BROWN	INCLUDED	10 O'CLOCK (2)
3	20 AWG	48"	GROUND / SHIELD FOR SENSOR	BLUE & CABLE SHIELD	INCLUDED	2 O'CLOCK (1)

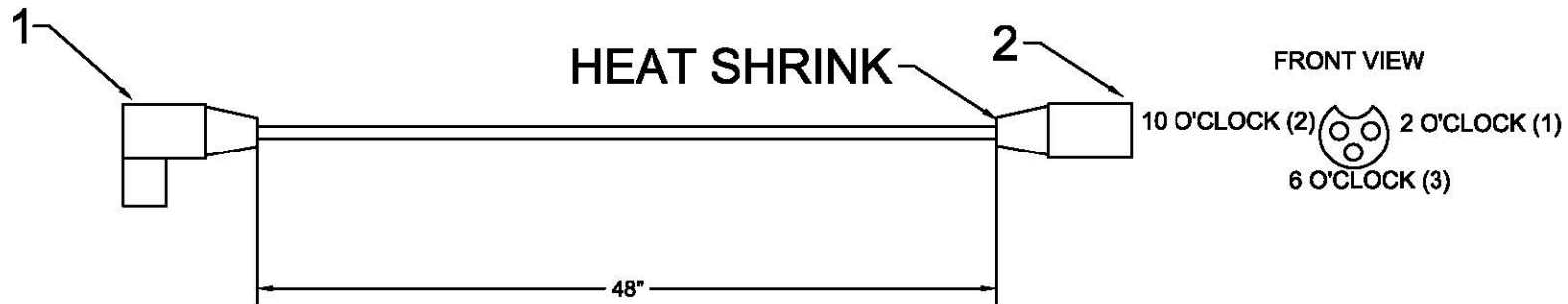

**CIRUS**  
CONTROLS LLC  
9200 WYOMING AVE. N. SUITE 320  
BROOKLYN PARK, MN 55445  
Phone: (763) 493-9380  
Fax: (763) 493-9340

THIS DRAWING IS THE PROPERTY OF CIRUS CONTROLS.  
THIS IS TO BE CONSIDERED CONFIDENTIAL AND  
PROPRIETARY NO REPRODUCTION IN WHOLE OR PART  
WITH OUT PERMISSION IS ALLOWED.

REV	DATE	DESCRIPTION				
A	9-9-03	-	SPREADER CABLE SYSTEM			
B	-	-				
C	-	-				
D	-	-				
E	-	-	M12 TO CONXALL			
DESIGN:	DRAWN:	AS BUILT:	PROJECT NUMBER:	SCALE:	DATE:	REV.
JTM	JTM	-	TS-2006	NONE	3-11-04	-
			SHT 1 OF 1			

EuroFast  
Female Pins,  
Female Threads  
or Coupling Nut



4-pin



5-pin

EuroFast  
Male Pins,  
Male Threads  
or Coupling Nut



4-pin



5-pin

## B.O.M.

ITEM	QTY	PART NUMBER	DESCRIPTION
1	1	WAYTEK 38044	3 PIN WEATERPACK (SHROUD HALF)
2	1	WS 4.4T-2/S653	M12 90 DEGREE AND CABLE
3	3	WAYTEK 30034	PINS WEATHER PACK
4	3	WAYTEK 39000	SEAL FOR WEATHER PACK

**NOTES:**

1. To specify nylon coupling nut, add "K" to part number.  
For example: WK(S)...to WK(S)K...
2. To specify stainless steel coupling nut, add a "V" to part number.  
For example: WK(S)...to WK(S)V...

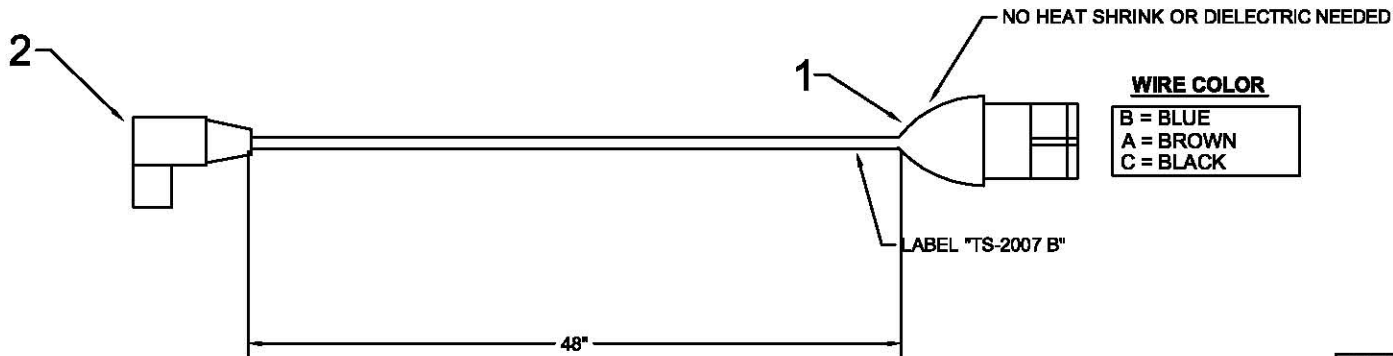
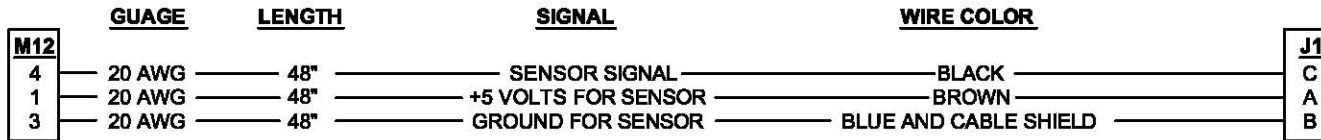

**CIRUS CONTROLS LLC**  
 9200 WYOMING AVE. N. SUITE 320  
 BROOKLYN PARK, MN 55445  
 Phone: (763) 493-9380  
 Fax: (763) 493-9340

THIS DRAWING IS THE PROPERTY OF CIRUS CONTROLS.  
 THIS IS TO BE CONSIDERED CONFIDENTIAL AND  
 PROPRIETARY NO REPRODUCTION IN WHOLE OR PART  
 WITH OUT PERMISSION IS ALLOWED.

REV	DATE	DESCRIPTION
A	3-16-05	CHANGED HEAT SHRINK NOTE
B	1-23-07	CHANGED PINOUT OF WEATHER PACK
C	-	-
D	-	-
E	-	-

DESIGN: JTM	DRAWN: JTM	AS BUILT: -	PROJECT NUMBER: TS-2007B	SCALE: NONE	DATE: 1-23-07	REV: B
			SHEET 1 OF 1			

SPREADER CABLE SYSTEM

M12 TO WEATHER PACK

**WIRING DIAGRAM**

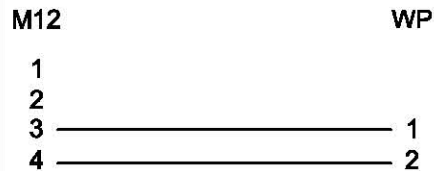

**B.O.M.**

ITEM	QTY	PART NUMBER	DESCRIPTION
1	1	WS 4T - .5	M12 90 degree connector and cable
2	1	38043 (waytek)	weatherpack 2 pin (tower half)
3	2	30035 (waytek)	tower terminals 20- 18 awg
4	2	39000 (waytek)	weatherpack seals

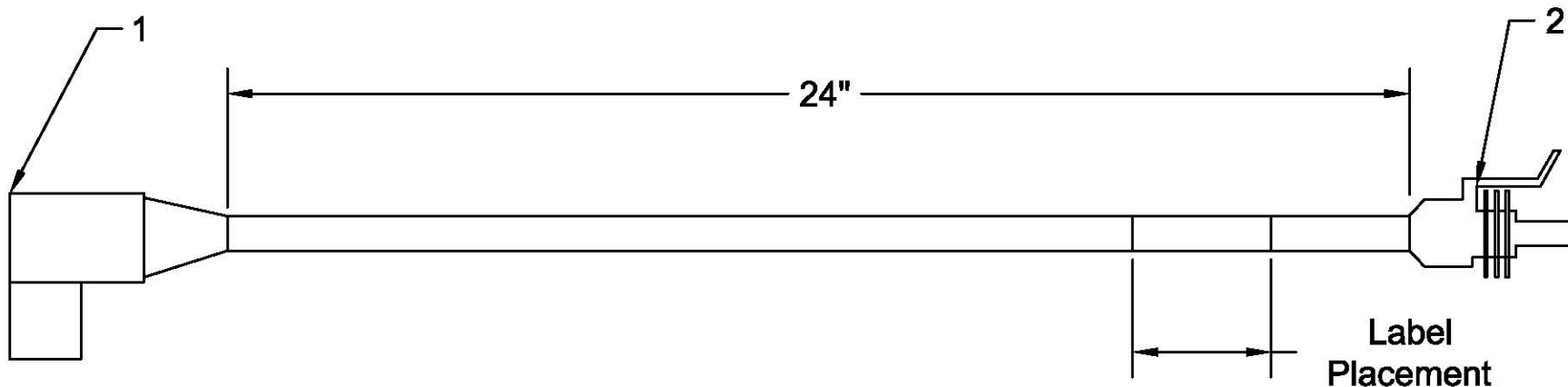

**Notes:**

- 18 AWG, 2 Conductor cable
- Label to be white w/ black printing and located on cable per drawing. (mylar w/ clear cover, all caps, 15pt font)
- M12 MATES TO SENSOR BOX 4MB12-4P2

**Cirus Controls** 9200 Wyoming Ave. N, Suite 320  
 Brooklyn Park, MN 55445  
 Tel: (763) 493-9380  
 Fax: (763) 493-9340

THIS DRAWING IS THE PROPERTY OF CIRUS CONTROLS  
 THIS IS TO BE CONSIDERED CONFIDENTIAL AND NO  
 REPRODUCTION IN WHOLE OR PART WITH OUT  
 PERMISSION IS ALLOWED.

REV	DATE	DESCRIPTION
A	2-28-05	changed amp to WP
B	-	-
C	-	-
D	-	-
E	-	-

DESIGN: JTM DRAWN: JTM AS BUILT: -

SPREADER CABLE SYSTEM			
M12 TO WEATHERPACK			
PROJECT NUMBER:	SCALE:	DATE:	REV:
TS-2010	NONE	2-28-05	A
SHT 1 OF 1			

**WIRING DIAGRAM**

M12	AMP
1	
2	
3	1
4	2

**B.O.M.**

ITEM	QTY	PART NUMBER	DESCRIPTION
1	1	????	M12 90 degree connector and cable
2	1	282189 - 1	AMP Junior Timer RECEPTACLE
3	2	929930 - 3	FEMALE TERMINAL for AMP Junior Timer
4	2	828905 - 1	18 AWG SEAL for AMP Junior Timer

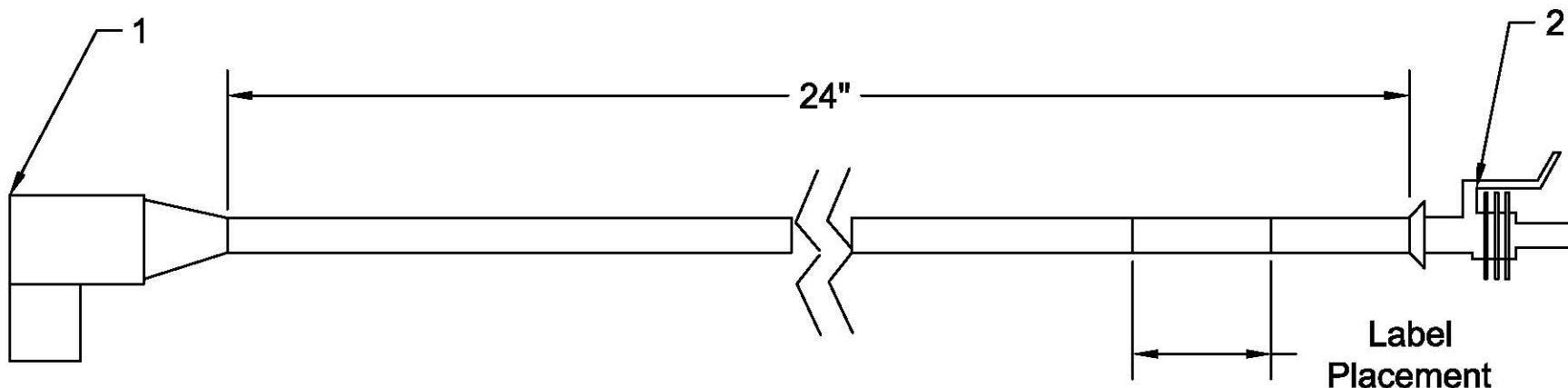

**Notes:**

- 18 AWG, 2 Conductor cable
- Label to be white w/ black printing and located on cable per drawing. (mylar w/ clear cover, all caps, 15pt font)
- M12 MATES TO SENSOR BOX 4MB12-4P2

**Cirus Controls** 9200 Wyoming Ave. N, Suite 320  
 Brooklyn Park, MN 55445  
 Tel: (763) 493-9380  
 Fax: (763) 493-9340

THIS DRAWING IS THE PROPERTY OF CIRUS CONTROLS  
 THIS IS TO BE CONSIDERED CONFIDENTIAL AND NO  
 REPRODUCTION IN WHOLE OR PART WITH OUT  
 PERMISSION IS ALLOWED.

REV	DATE	DESCRIPTION
A	-	-
B	-	-
C	-	-
D	-	-
E	-	-

DESIGN: JTM		DRAWN: JTM		AS BUILT: -		PROJECT NUMBER: TS-2011		SCALE: NONE		DATE: 9-27-04		REV: -	
SPREADER CABLE SYSTEM													
M12 TO AMP JR Timer													
SHT 1 OF 1													

# B.O.M.

ITEM	QTY	PART NUMBER	DESCRIPTION
1	1	????	M12 connector and cable
2	1	282080-1	AMP Superseal 1.5 RECEPTACLE
3	2	183025-1	FEMALE TERMINAL for Superseal 1.5
4	2	281934-2	18 AWG SEAL for Superseal 1.5

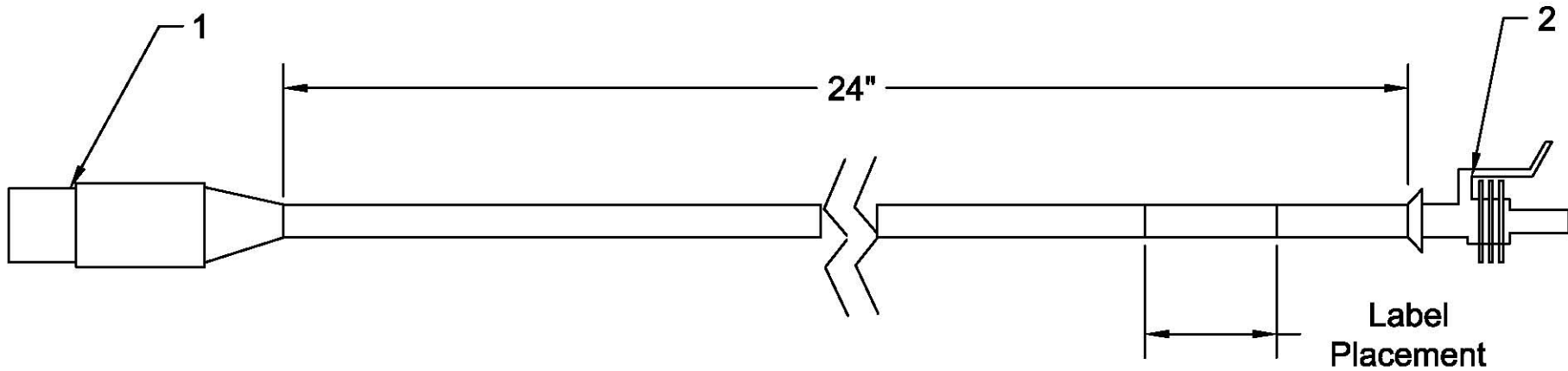

**Notes:**

- 18 AWG, 2 Conductor cable
- Label to be white w/ black printing and located on cable per drawing. (mylar w/ clear cover, all caps, 15pt font)
- M12 MATES TO SENSOR BOX 4MB12-4P2

**Cirus Controls** 9200 Wyoming Ave. N, Suite 320  
 Brooklyn Park, MN 55445  
 Tel: (763) 493-9380  
 Fax: (763) 493-9340

THIS DRAWING IS THE PROPERTY OF CIRUS CONTROLS  
 THIS IS TO BE CONSIDERED CONFIDENTIAL AND NO  
 REPRODUCTION IN WHOLE OR PART WITH OUT  
 PERMISSION IS ALLOWED.

REV	DATE	DESCRIPTION
A	-	-
B	-	-
C	-	-
D	-	-
E	-	-

<b>SPREADER CABLE SYSTEM</b>			
<b>M12 TO AMP PLUG</b>			
DESIGN: JTM	DRAWN: JTM	AS BUILT: -	PROJECT NUMBER: TS-2012
SCALE: NONE		DATE: 3-29-04	REV: -
			SHT 1 OF 1

# B.O.M.

<u>ITEM</u>	<u>QTY</u>	<u>PART NUMBER</u>	<u>DESCRIPTION</u>
1	1	????	M12 connector and cable
2	1	317-1398-000	SURESEAL BOOT
3	1	120-1804-000	SURESEAL RECEPTACLE
4	1	031-1267-001	SURESEAL TIN SOCKET
5	1	030-2196-001	SURESEAL TIN PIN

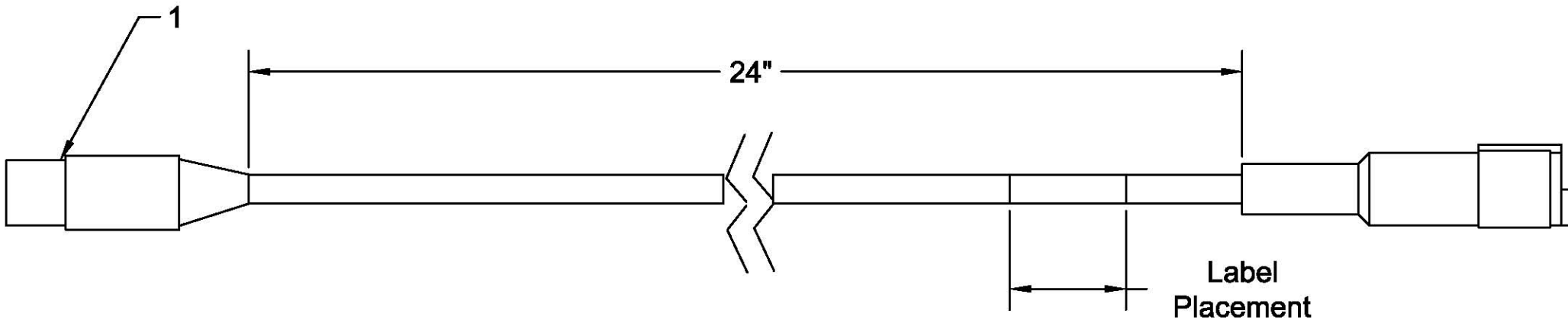



**Notes:**

- 18 AWG, 2 Conductor cable
- Label to be white w/ black printing and located on cable per drawing. (mylar w/ clear cover, all caps, 15pt font)
- M12 MATES TO SENSOR BOX 4MB12-4P2

**Cirus Controls** 9200 Wyoming Ave. N, Suite 320  
 Brooklyn Park, MN 55445  
 Tel: (763) 493-9380  
 Fax: (763) 493-9340

THIS DRAWING IS THE PROPERTY OF CIRUS CONTROLS  
 THIS IS TO BE CONSIDERED CONFIDENTIAL AND NO  
 REPRODUCTION IN WHOLE OR PART WITH OUT  
 PERMISSION IS ALLOWED.

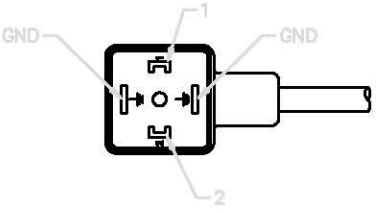
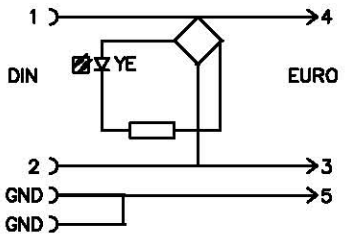
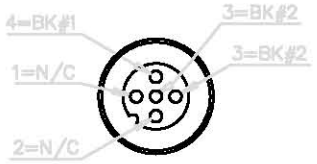
REV	DATE	DESCRIPTION											
A	-	-	SPREADER CABLE SYSTEM										
B	-	-											
C	-	-											
D	-	-											
E	-	-											
M12 TO ITT CANNON PLUG													
DESIGN:	JTM	DRAWN:	JTM	AS BUILT:	-	PROJECT NUMBER:	TS-2013	SCALE:	NONE	DATE:	3-29-04	REV.	-
											SHT 1 OF 1		

DIN 43650 (FEMALE)	WIRING DIAGRAM	MALE END VIEW	SPECIFICATIONS																									
		 	<table border="1"> <tr><td>CONTACT CARRIER MATERIAL</td><td>NYLON OR PUR</td></tr> <tr><td>CONTACT MATERIAL/PLATING (VALVE)</td><td>SILVER-PLATED BRASS</td></tr> <tr><td>CONTACT MATERIAL/PLATING (EUROFAST)</td><td>GOLD-PLATED BRASS</td></tr> <tr><td>MOLDED HEAD MATERIAL</td><td>POLYURETHANE</td></tr> <tr><td>COUPLING NUT MATERIAL</td><td>NICKEL-PLATED BRASS</td></tr> <tr><td>RATED CURRENT</td><td>4.0 A</td></tr> <tr><td>RATED VOLTAGE</td><td>24-48 VAC/DC</td></tr> <tr><td>OUTER JACKET MATERIAL/COLOR</td><td>PUR/GREY</td></tr> <tr><td>NUMBER OF CONDUCTORS</td><td>3x18 AWG</td></tr> <tr><td>CONDUCTOR INSULATION</td><td>PVC</td></tr> <tr><td>TEMPERATURE RATING</td><td>-40°C to +105°C (-40°F to +221°F)</td></tr> <tr><td>PROTECTION CLASS</td><td>MEETS NEMA 1,3,4,6P AND IEC IP67</td></tr> </table>	CONTACT CARRIER MATERIAL	NYLON OR PUR	CONTACT MATERIAL/PLATING (VALVE)	SILVER-PLATED BRASS	CONTACT MATERIAL/PLATING (EUROFAST)	GOLD-PLATED BRASS	MOLDED HEAD MATERIAL	POLYURETHANE	COUPLING NUT MATERIAL	NICKEL-PLATED BRASS	RATED CURRENT	4.0 A	RATED VOLTAGE	24-48 VAC/DC	OUTER JACKET MATERIAL/COLOR	PUR/GREY	NUMBER OF CONDUCTORS	3x18 AWG	CONDUCTOR INSULATION	PVC	TEMPERATURE RATING	-40°C to +105°C (-40°F to +221°F)	PROTECTION CLASS	MEETS NEMA 1,3,4,6P AND IEC IP67	
CONTACT CARRIER MATERIAL	NYLON OR PUR																											
CONTACT MATERIAL/PLATING (VALVE)	SILVER-PLATED BRASS																											
CONTACT MATERIAL/PLATING (EUROFAST)	GOLD-PLATED BRASS																											
MOLDED HEAD MATERIAL	POLYURETHANE																											
COUPLING NUT MATERIAL	NICKEL-PLATED BRASS																											
RATED CURRENT	4.0 A																											
RATED VOLTAGE	24-48 VAC/DC																											
OUTER JACKET MATERIAL/COLOR	PUR/GREY																											
NUMBER OF CONDUCTORS	3x18 AWG																											
CONDUCTOR INSULATION	PVC																											
TEMPERATURE RATING	-40°C to +105°C (-40°F to +221°F)																											
PROTECTION CLASS	MEETS NEMA 1,3,4,6P AND IEC IP67																											

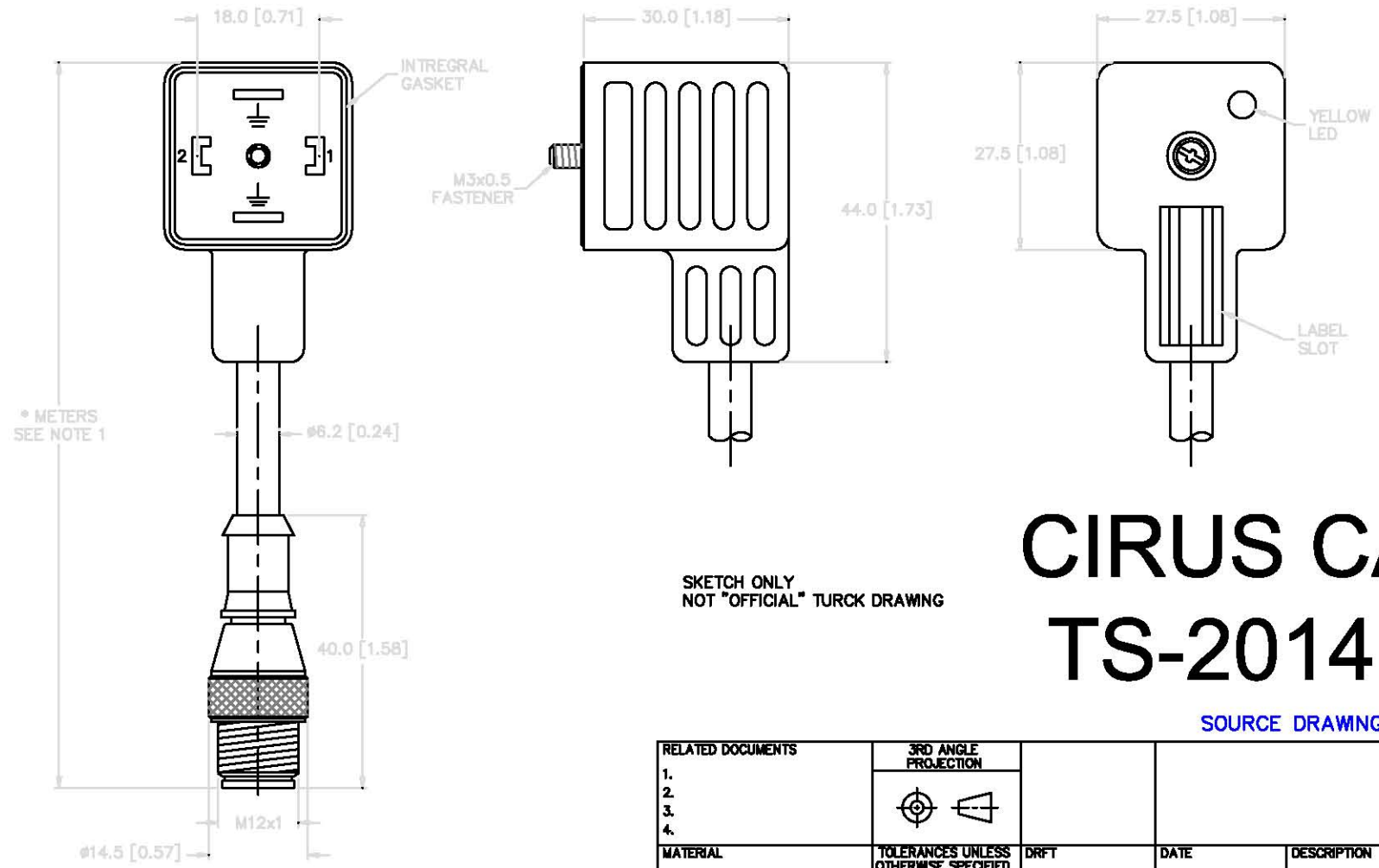

SKETCH ONLY  
NOT "OFFICIAL" TURCK DRAWING

# CIRUS CABLE # TS-2014

SOURCE DRAWING - FOR REFERENCE ONLY

NOTES:  
1. "\*" INDICATES CABLE LENGTH IN METERS. CONTACT TURCK TO ORDER SPECIFIC LENGTHS.

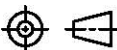
RELATED DOCUMENTS 1. 2. 3. 4.		3RD ANGLE PROJECTION 															
MATERIAL  FINISH		TOLERANCES UNLESS OTHERWISE SPECIFIED		DRFT DSGN DATE SCALE		DESCRIPTION VAS 22-B653-0.6M-RS 5.3T											
				UNIT OF MEASUREMENT  DO NOT SCALE THIS DRAWING		IDENTIFICATION NO. <b>TS-2014</b> REV											
<table border="1"> <tr><td>REV</td><td>DESCRIPTION</td></tr> <tr><td>A</td><td>DRAWING RELEASE</td></tr> </table>	REV	DESCRIPTION	A	DRAWING RELEASE	<table border="1"> <tr><td>BY</td><td>DATE</td></tr> <tr><td>JB</td><td>02/11/03</td></tr> </table>	BY	DATE	JB	02/11/03	<table border="1"> <tr><td>ECO NO.</td></tr> <tr><td></td></tr> </table>	ECO NO.					FILE:	SHEET OF
REV	DESCRIPTION																
A	DRAWING RELEASE																
BY	DATE																
JB	02/11/03																
ECO NO.																	



# LOOKING IN AT M12 PINS

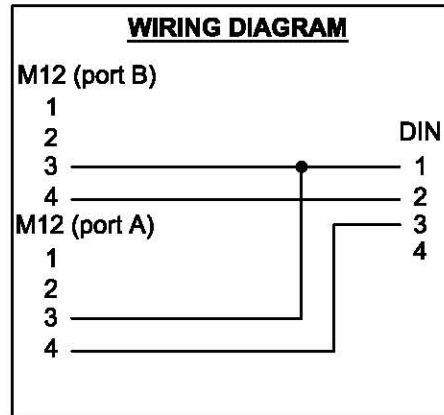
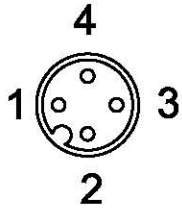

## B.O.M.

ITEM	QTY	PART NUMBER	DESCRIPTION
1	2	WSC 4.4T - .5	M12 90 degree connector and cable
2	1	VAS 3-AW	Field wireable DIN connector

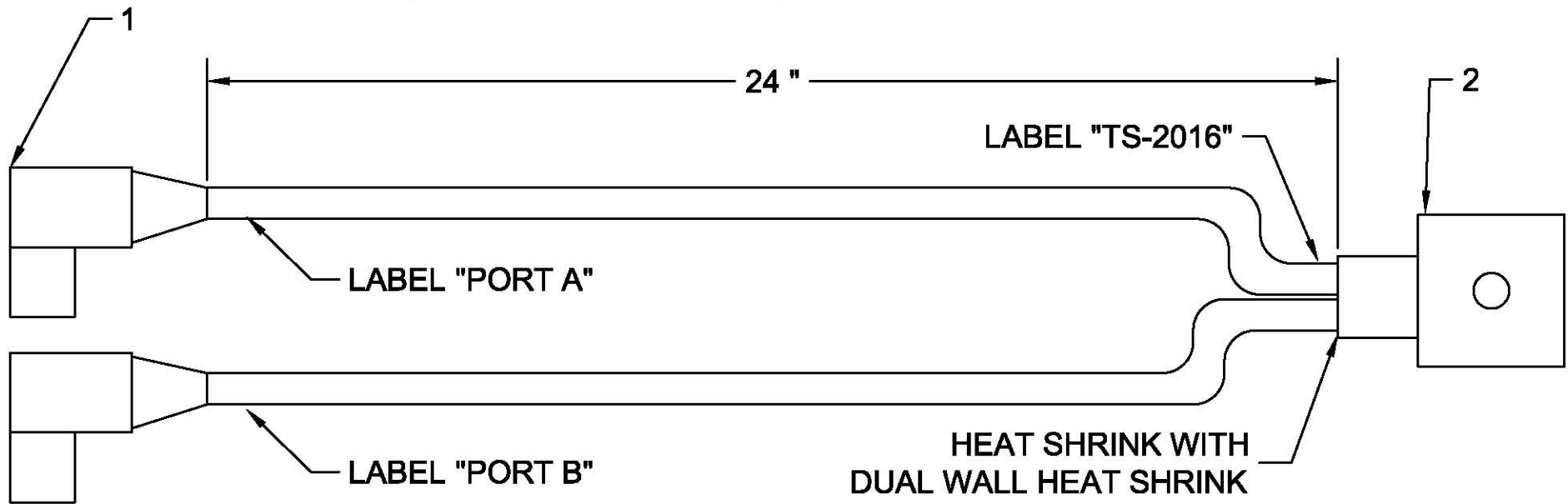

**Notes:**

- 18 AWG, 3 Conductor cable
- Label to be white w/ black printing and located on cable per drawing. (mylar w/ clear cover, all caps, 15pt font)
- M12 MATES TO SENSOR BOX 4MB12-4P2
- CABLE SHOULD BE INDIVIDUALLY BAGGED AND LABELED.

**Cirus Controls**  
 9200 Wyoming Ave. N, Suite 320  
 Brooklyn Park, MN 55445  
 Tel: (763) 483-9380  
 Fax: (763) 483-9340

THIS DRAWING IS THE PROPERTY OF CIRUS CONTROLS  
 THIS IS TO BE CONSIDERED CONFIDENTIAL AND NO  
 REPRODUCTION IN WHOLE OR PART WITH OUT  
 PERMISSION IS ALLOWED.

REV	DATE	DESCRIPTION	SPREADER CABLE SYSTEM		
A	-	-	2 M12 TO DIN (WALVOIL VALVE)		
B	-	-	PROJECT NUMBER:	SCALE:	DATE: 9-8-08
C	-	-	TS-2016	NONE	REV. -
D	-	-			SHT 1 OF 1
E	-	-			

**WIRING DIAGRAM**

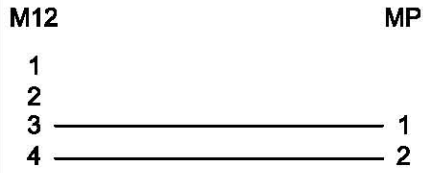

**B.O.M.**

ITEM	QTY	PART NUMBER	DESCRIPTION
1	1	WS 4T - .5	M12 90 degree connector and cable
2	1	38201 (waytek)	FEMALE METRI-PACK 150 2 pin
3	2	31077 (waytek)	FEMALE TERMINALS 16-18 AWG
4	2	38202 (waytek)	TPA LOCK
4	2	39006 (waytek)	CABLE SEALS

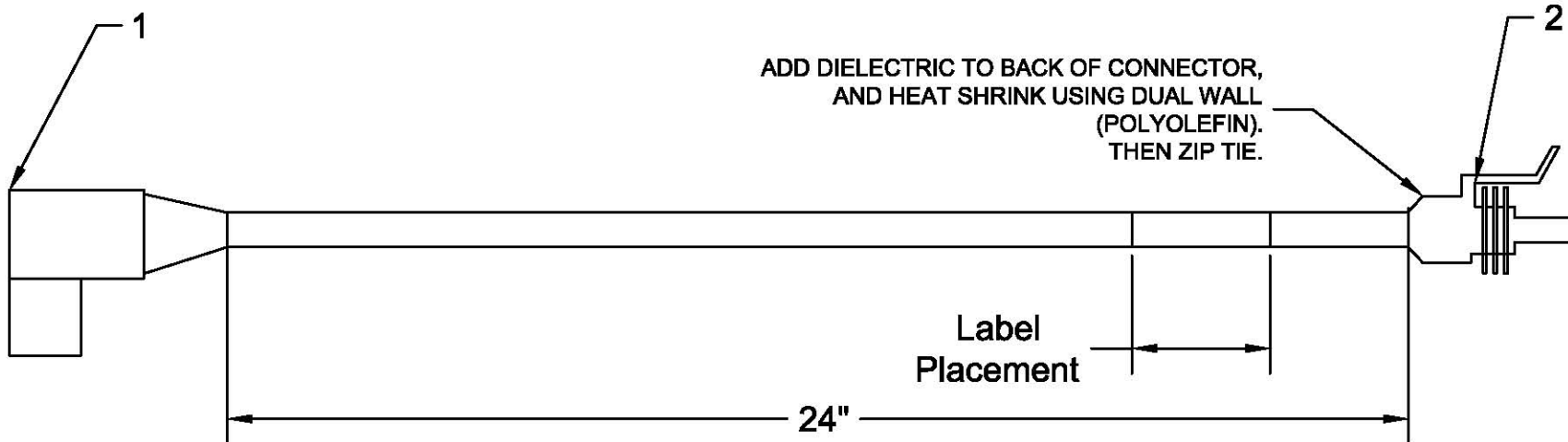

**Notes:**

- 18 AWG, 2 Conductor cable
- Label to be white w/ black printing and located on cable per drawing. (mylar w/ clear cover, all caps, 15pt font)
- M12 MATES TO SENSOR BOX 4MB12-4P2

**Cirus Controls**  
 9200 Wyoming Ave. N, Suite 320  
 Brooklyn Park, MN 55445  
 Tel: (763) 493-9380  
 Fax: (763) 493-9340

#TS-2017

THIS DRAWING IS THE PROPERTY OF CIRUS CONTROLS  
 THIS IS TO BE CONSIDERED CONFIDENTIAL AND NO  
 REPRODUCTION IN WHOLE OR PART WITH OUT  
 PERMISSION IS ALLOWED.

REV	DATE	DESCRIPTION				
A	-	-	SPREADER CABLE SYSTEM			
B	-	-				
C	-	-				
D	-	-				
E	-	-				
DESIGN:	DRAWN:	AS BUILT:	PROJECT NUMBER:	SCALE:	DATE:	REV:
JTM	JTM	-	TS-2017	NONE	6-2-08	-
			SHT 1 OF 1			

# B.O.M.

**NOTES:**

1. AVAILABLE CABLES FOR DIFFERENT VALVE TYPES  
(ORDER INDIVIDUALLY):  
PN# VAS 22-B653-.6M-WS 5.3T (DIN VALVE)
2. PLUG FOR PORTS NOT USED:  
PN# VZ-3

ITEM	QTY	PART NUMBER	DESCRIPTION
1	1	4MB12 - 4P2	HYDRAULIC TRUNK AND BOX (TURCK)
2	1	39-01-2060 (Digi-Key #WM3702-ND)	MOLEX 6 PIN
3	6	39-00-0039 (Digi-Key #WM2501-ND)	MOLEX TERMINALS 18-24 AWG
4	1	WAYTEK 30513	.250 FEMALE SPADE
5	1	WAYTEK 30512	.250 MALE SPADE

LABEL CABLE WITH  
"TS-2018 HYD OUT"

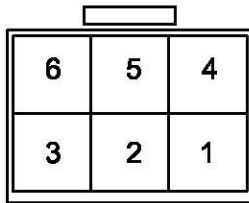
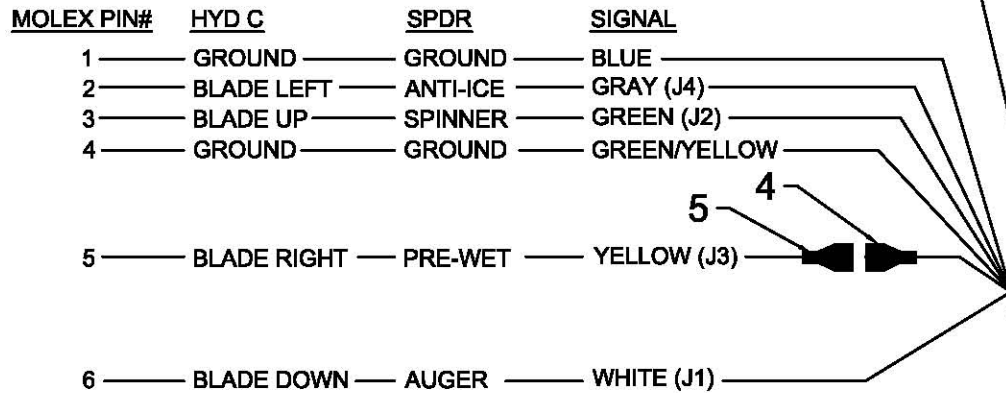

**BACK VIEW**  
(SIDE PINS ARE INSERTED FROM)

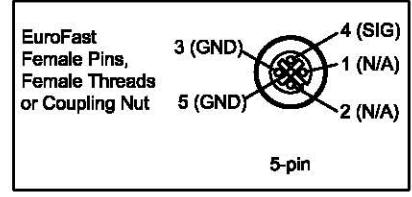
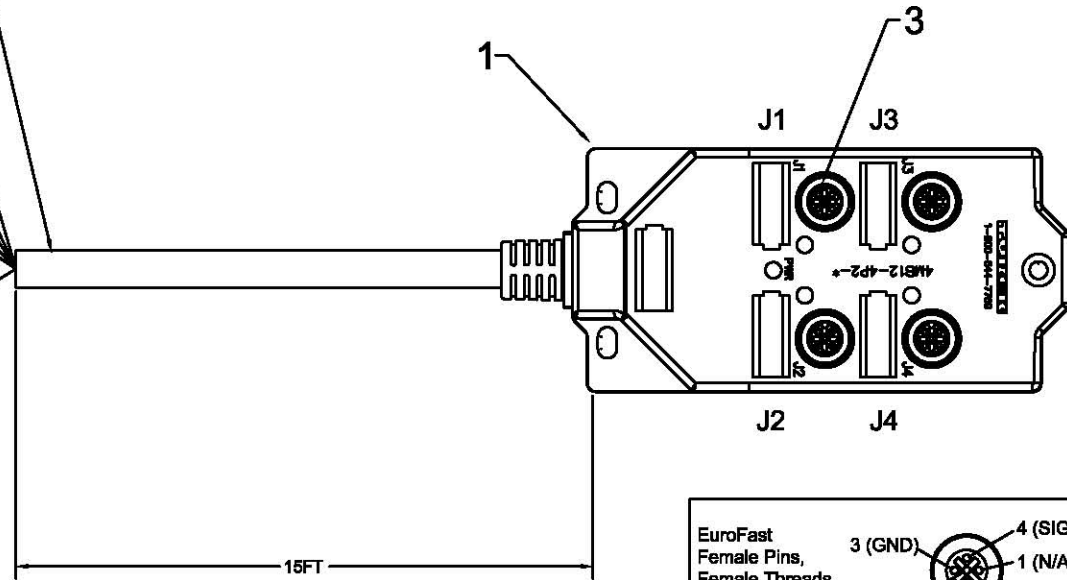

THIS DRAWING IS THE PROPERTY OF CIRUS CONTROLS. THIS IS TO BE CONSIDERED CONFIDENTIAL AND PROPRIETARY. NO REPRODUCTION IN WHOLE OR PART WITH OUT PERMISSION IS ALLOWED.

REV	DATE	DESCRIPTION
A	11-18-04	ADDED HYD C FUNCTIONS
B	-	-
C	-	-
D	-	-
E	-	-

DESIGN: JTM      DRAWN: JTM      AS BUILT: -

**CIRUS CONTROLS LLC**  
9200 WYOMING AVE. N. SUITE 320  
BROOKLYN PARK, MN 55445  
Phone: (763) 493-9380  
Fax: (763) 493-9340

SPREADER CABLE SYSTEM			
HYDRAULIC CABLE			
PROJECT NUMBER:	SCALE:	DATE:	REV:
TS-2018	NONE	11-18-04	A
			SHT 1 OF 1

**WIRING DIAGRAM**

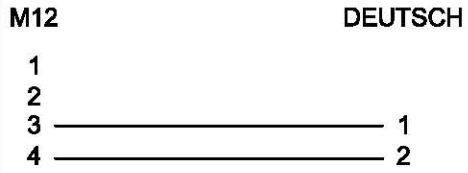

**B.O.M.**

ITEM	QTY	PART NUMBER	DESCRIPTION
1	1	WS 4T - .5	M12 90 degree connector and cable
2	1	DT06-2S (LADD)	DEUTSCH PLUG
3	2	0462-201-16141 (LADD)	FEMALE TERMINALS 16-18 AWG
4	1	W2S (LADD)	DEUTSCH WEDGE LOCK

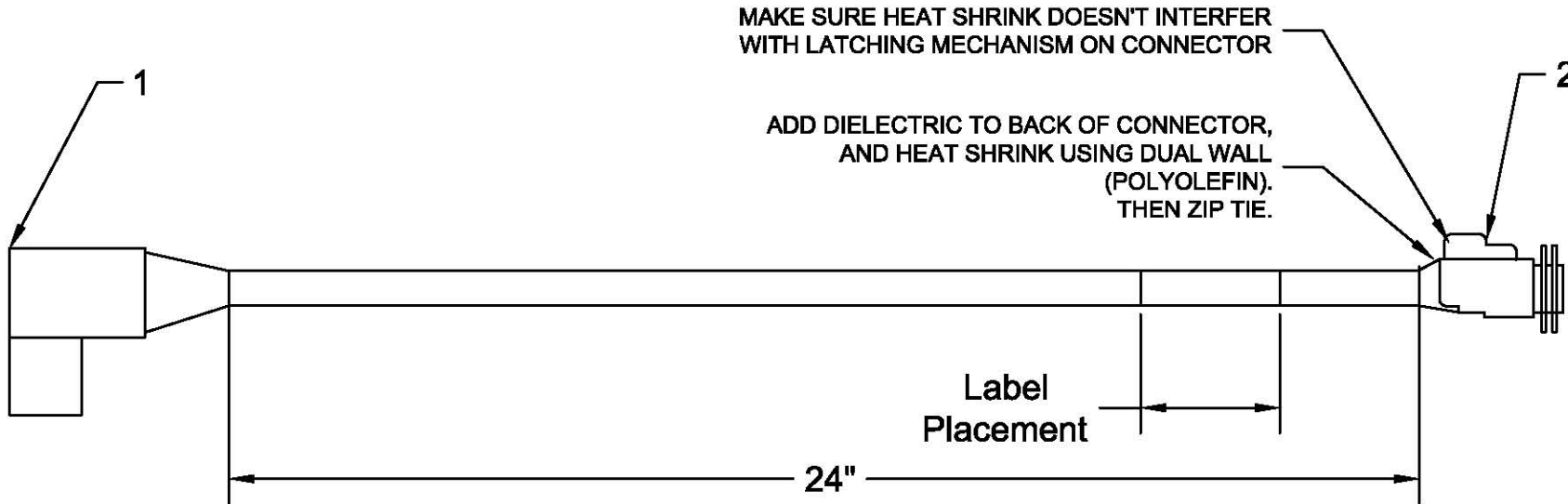

**Notes:**

- 18 AWG, 2 Conductor cable
- Label to be white w/ black printing and located on cable per drawing. (mylar w/ clear cover, all caps, 15pt font)
- M12 MATES TO SENSOR BOX 4MB12-4P2

**Cirus Controls**  
 9200 Wyoming Ave. N, Suite 320  
 Brooklyn Park, MN 55445  
 Tel: (763) 493-9380  
 Fax: (763) 493-9340

#TS-2020

THIS DRAWING IS THE PROPERTY OF CIRUS CONTROLS  
 THIS IS TO BE CONSIDERED CONFIDENTIAL AND NO  
 REPRODUCTION IN WHOLE OR PART WITH OUT  
 PERMISSION IS ALLOWED.

REV	DATE	DESCRIPTION			
A	-	-	SPREADER CABLE SYSTEM		
B	2-21-07	ADDED HEAT SHRINK NOTE			
C	-	-			
D	-	-			
E	-	-			
M12 TO DEUTSCH DT06-2S			PROJECT NUMBER	SCALE	DATE
DESIGN:	DRAWN:	AS BUILT:	TS-2020	NONE	11-28-06
JTM	JTM	-			SHT 1 OF 1
					REV. B

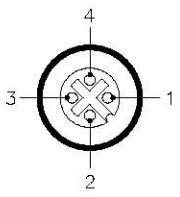
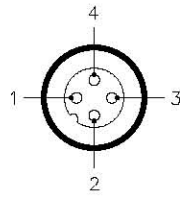
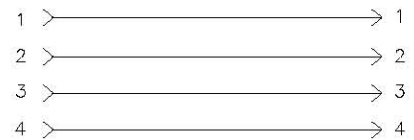
FEMALE END VIEW	MALE END VIEW	WIRING DIAGRAM	SPECIFICATIONS	
			CONTACT CARRIER MATERIAL	POLYURETHANE
			CONTACT MATERIAL/PLATING	GOLD-PLATED BRASS
			COUPLING NUT	NICKEL-PLATED BRASS
			RATED CURRENT [A]	4.0 A
			RATED VOLTAGE [V]	250 VAC/300 VDC
			OUTER JACKET MATERIAL/COLOR	PVC, GRAY
			CONDUCTOR INSULATION MATERIAL	PVC
			NUMBER OF CONDUCTORS [AWG]	4x22 AWG
			DRAIN/SHIELD	22 AWG DRAIN/FOIL SHIELD
			TEMPERATURE RATING	-40°C to +105°C (-40°F to +221°F)
			PROTECTION CLASS	MEETS NEMA 1,3,4,6,13 AND IEC IP67

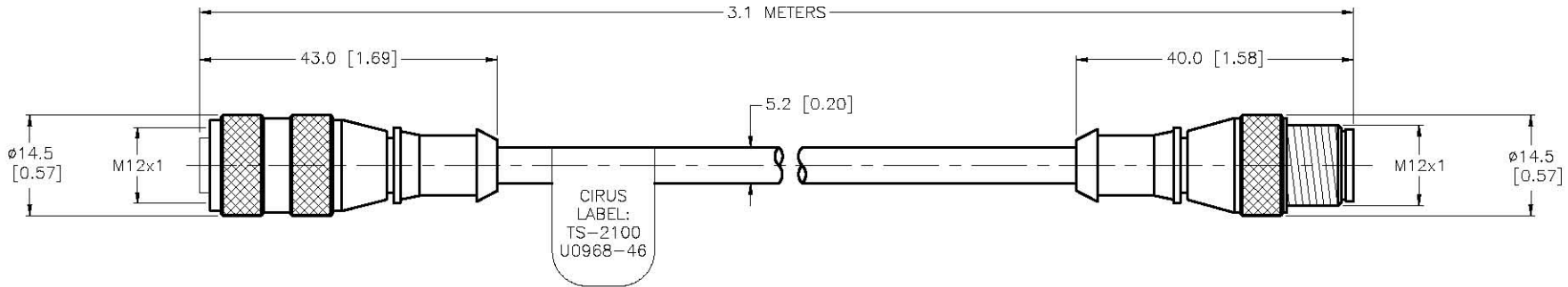

CABLE LENGTH	TOLERANCE
ALL LENGTHS	+ 4% (OR 50mm) OF LENGTH - 0% (OR 0mm) OF LENGTH WHICHEVER IS GREATER
STRIP LENGTH	TOLERANCE
0-7mm	±0.5mm
8-29mm	±1.0mm
30-49mm	±2.0mm
50-69mm	±3.0mm
70-100mm	±4.0mm
OVER 100mm	±5.0mm

SOURCE DRAWING - FOR REFERENCE ONLY

RELATED DOCUMENTS	3RD ANGLE PROJECTION	THIS DOCUMENT IS PROPERTY OF TURCK INC. USE OF THIS DOCUMENT WITHOUT WRITTEN PERMISSION IS PROHIBITED.		3000 CAMPUS DRIVE MINNEAPOLIS, MN 55441 1-800-544-7789 (763) 553-7300 (763) 553-0708 fax turck.com	
1.		DRFT	JBJ	DATE	04/29/04
2.		DSGN		SCALE	1=1.0
3.	TOLERANCES UNLESS OTHERWISE SPECIFIED	UNIT OF MEASUREMENT		DESCRIPTION	
4.	0.5 TO 6 ±0.1 6 TO 30 ±0.2 30 TO 200 ±0.3 OVER 200 ±0.4 ANGLES ±1° ALL INCH DIMENSIONS ARE REFERENCE ONLY	MILLIMETER [ INCH ]		TS-2100	
MATERIAL	SEE SPECIFICATIONS	DO NOT SCALE THIS DRAWING		IDENTIFICATION NO.	U0968-46
FINISH	SEE SPECIFICATIONS			REV	A
				FILE:	CIRUS\U0968-46
				SHEET	1 OF 1

A	DRAWING RELEASE	PJ	07/14/04	
REV	DESCRIPTION	BY	DATE	ECO NO.

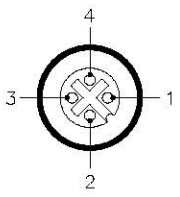
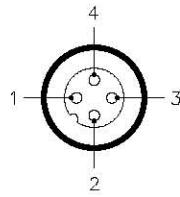
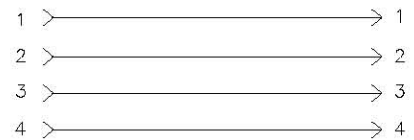
FEMALE END VIEW	MALE END VIEW	WIRING DIAGRAM	SPECIFICATIONS	
			CONTACT CARRIER MATERIAL	POLYURETHANE
			CONTACT MATERIAL/PLATING	GOLD-PLATED BRASS
			COUPLING NUT	NICKEL-PLATED BRASS
			RATED CURRENT [A]	4.0 A
			RATED VOLTAGE [V]	250 VAC/300 VDC
			OUTER JACKET MATERIAL/COLOR	PVC, GRAY
			CONDUCTOR INSULATION MATERIAL	PVC
			NUMBER OF CONDUCTORS [AWG]	4x22 AWG
			DRAIN/SHIELD	22 AWG DRAIN/FOIL SHIELD
			TEMPERATURE RATING	-40°C to +105°C (-40°F to +221°F)
			PROTECTION CLASS	MEETS NEMA 1,3,4,6,13 AND IEC IP67

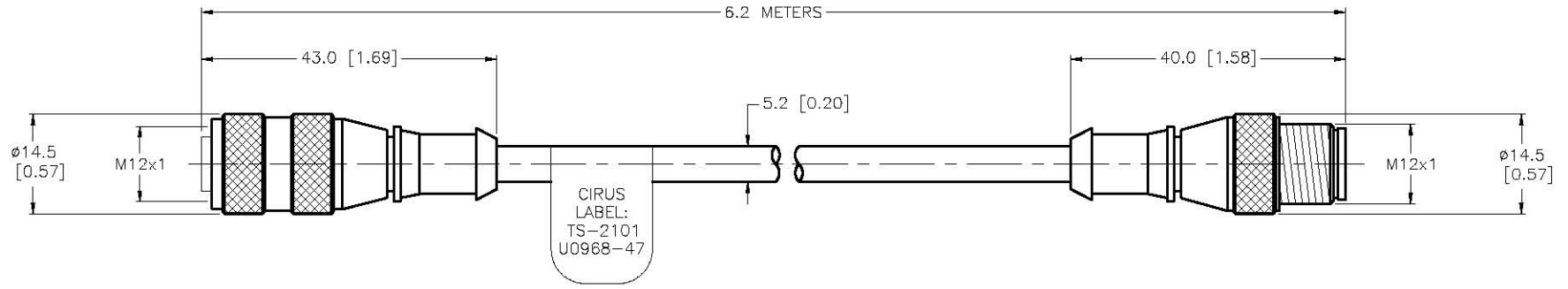

CABLE LENGTH	TOLERANCE
ALL LENGTHS	+ 4% (OR 50mm) OF LENGTH - 0% (OR 0mm) OF LENGTH WHICHEVER IS GREATER
STRIP LENGTH	TOLERANCE
0-7mm	±0.5mm
8-29mm	±1.0mm
30-49mm	±2.0mm
50-69mm	±3.0mm
70-100mm	±4.0mm
OVER 100mm	±5.0mm

SOURCE DRAWING - FOR REFERENCE ONLY

RELATED DOCUMENTS	3RD ANGLE PROJECTION	THIS DOCUMENT IS PROPERTY OF TURCK INC. USE OF THIS DOCUMENT WITHOUT WRITTEN PERMISSION IS PROHIBITED.		3000 CAMPUS DRIVE MINNEAPOLIS, MN 55441 1-800-544-7789 (763) 553-7300 (763) 553-0708 fax turck.com	
1.		DRFT	JBJ	DATE	04/29/04
2.		DSGN		SCALE	1=1.0
3.		UNIT OF MEASUREMENT		DESCRIPTION	
4.		MILLIMETER [ INCH ]		TS-2101	
MATERIAL	TOLERANCES UNLESS OTHERWISE SPECIFIED	DO NOT SCALE THIS DRAWING		IDENTIFICATION NO.	
SEE SPECIFICATIONS	0.5 TO 6 ±0.1 6 TO 30 ±0.2 30 TO 200 ±0.3 OVER 200 ±0.4 ANGLES ±1° ALL INCH DIMENSIONS ARE REFERENCE ONLY			O0968-47	
FINISH	SEE SPECIFICATIONS			REV	
				A	
				FILE: CIRUS\U0968-47	
				SHEET 1 OF 1	

A	DRAWING RELEASE	PJ	07/14/04	
REV	DESCRIPTION	BY	DATE	ECO NO.

**B.O.M.**

ITEM	QTY	PART NUMBER	DESCRIPTION
1	1	RSM 96-10M/S90	MAIN SENSOR TRUNK (TURCK)
2	1	RKMC-CC	CAP FOR MAIN TRUNK
3	1	39-01-2060 (Digi-Key #WM3702-ND)	MOLEX 6 PIN
4	6	39-00-0039 (Digi-Key # WM2501-ND)	MOLEX TERMINALS 18-24 AWG

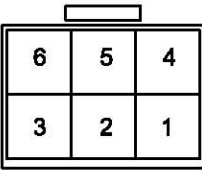

BACK VIEW  
(SIDE PINS ARE INSERTED FROM)

MOLEX PIN#	SIGNAL
1	GROUND :GREEN/YELLOW
2	ANTI-ICE SENSOR : GRAY
3	SPINNER SENSOR : GREEN
4	POWER (5 VDC OR 12 VDC) : BROWN
5	PRE-WET SENSOR : YELLOW
6	AUGER SENSOR : WHITE

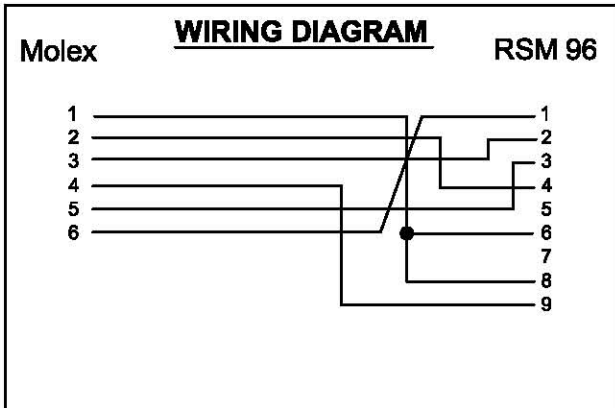
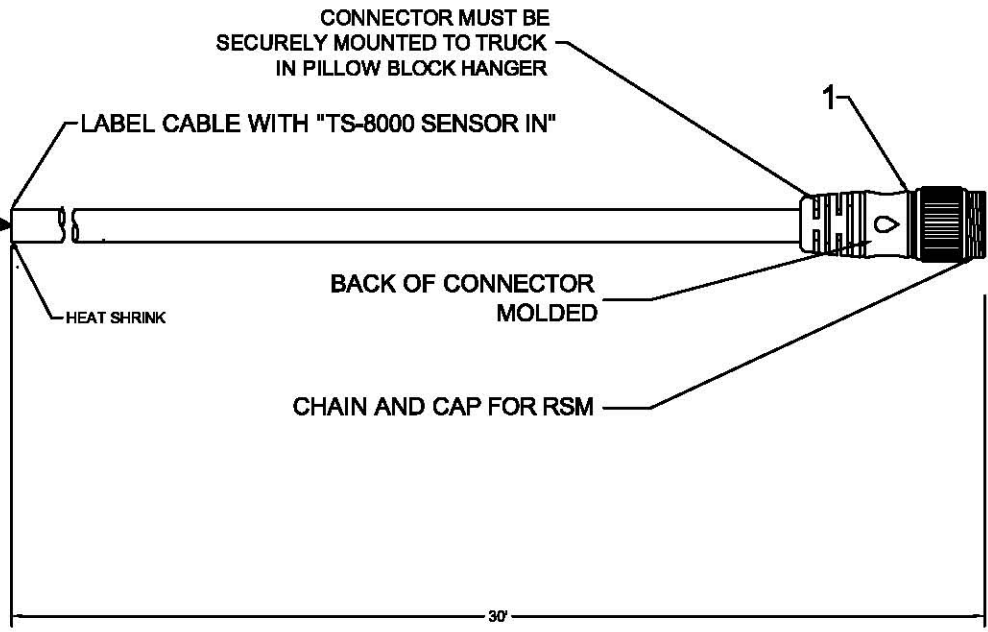

#TS-8000

THIS DRAWING IS THE PROPERTY OF CIRUS CONTROLS. THIS IS TO BE CONSIDERED CONFIDENTIAL AND PROPRIETARY NO REPRODUCTION IN WHOLE OR PART WITH OUT PERMISSION IS ALLOWED.

NOTE: THIS CABLE MATES TO TS-8001

**CIRUS CONTROLS LLC**  
 9210 WYOMING AVE. N. SUITE 200  
 BROOKLYN PARK, MN 55445  
 Phone: (763) 493-9380  
 Fax: (763) 493-9340

REV	DATE	DESCRIPTION
A	-	-
B	-	-
C	-	-
D	-	-
E	-	-

DESIGN: JTM	DRAWN: JTM	AS BUILT: -	PROJECT NUMBER: TS-8000	SCALE: NONE	DATE: 9-8-08	REV: -
			SPREADER CABLE SYSTEM			
			SENSOR CABLE			
			SHT 1 OF 1			

**B.O.M.**

**NOTES:**

1. NEEDS CABLE TS-8000 TO BE COMPLETE
2. AVAILABLE JUMPER CABLES FOR SENSORS (ORDERED INDIVIDUALLY):  
PN# WK 4.5-1.3-WS 4.5T/S653 (WHITE MOTOR)
3. PLUGS FOR UNUSED PORTS:  
PN# VZ-3

ITEM	QTY	PART NUMBER	DESCRIPTION
1	1	4MB12-4P2-2-RKM 96	VALVE BOX W/ CABLE (TURCK)
2	1 TO 3	VARIES	JUMPER CABLE TO SENSOR
3	1	RSMC-CC	CAP FOR CABLE TO BODY

PIN	SIGNAL
1	AUGER SIGNAL
2	SPINNER SIGNAL
3	PREWET SIGNAL
4	ANTI-ICE SIGNAL
6,8	GROUND
9	POWER

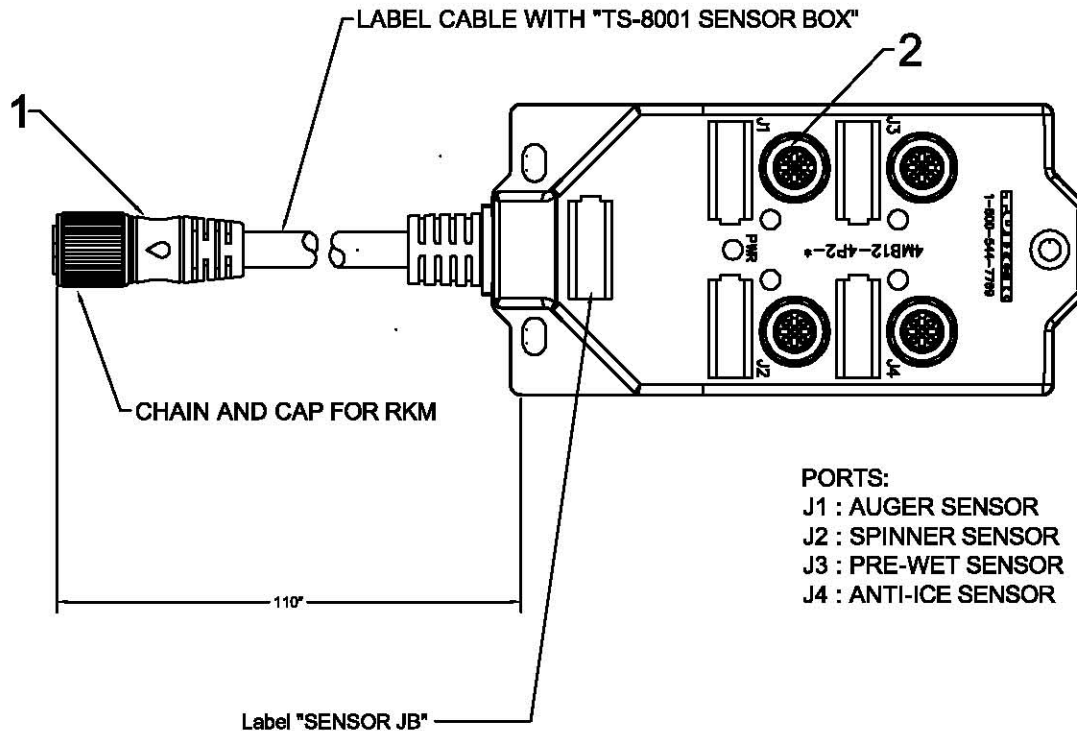

PORTS:  
 J1 : AUGER SENSOR  
 J2 : SPINNER SENSOR  
 J3 : PRE-WET SENSOR  
 J4 : ANTI-ICE SENSOR

**CIRUS**  
**CONTROLS LLC**  
 9210 WYOMING AVE. N. SUITE 200  
 BROOKLYN PARK, MN 55445  
 Phone: (763) 493-9380  
 Fax: (763) 493-9340

THIS DRAWING IS THE PROPERTY OF CIRUS CONTROLS.  
 THIS IS TO BE CONSIDERED CONFIDENTIAL AND  
 PROPRIETARY NO REPRODUCTION IN WHOLE OR PART  
 WITH OUT PERMISSION IS ALLOWED.

REV	DATE	DESCRIPTION	DESIGNER	DRAWN	AS BUILT	PROJECT NUMBER	SCALE	DATE	REV.
A	-	-	JTM	JTM	-	TS-8001	NONE	9-5-08	-
B	-	-							
C	-	-							
D	-	-							
E	-	-							

SPREADER CABLE SYSTEM

SENSOR BOX

SHT 1 OF 1





**B.O.M.**

ITEM	QTY	PART NUMBER	DESCRIPTION
2	1	RSM 126-10M/S90	MAIN ANTI-ICE BOOM TRUNK (TURCK)
3	1	RKMC-CC	CAP FOR MAIN TRUNK
5	1	39-01-2080 (DK#WM3703-ND)	MOLEX 8 PIN
6	8	39-00-0039 (DK#WM2501-ND)	MOLEX TERMINALS
7	1	WAYTEK 46025	10 AMP IN LINE FUSE HOLDER
8	1	WAYTEK 46026	10 AMP IN LINE FUSE HOLDER COVER
9	1	WAYTEK 46256	10 AMP FUSE

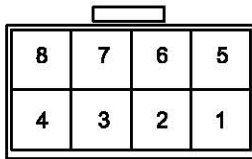

6 INCH LEADS TO CONNECTORS

BACK VIEW  
(SIDE PINS ARE INSERTED FROM)

MOLEX PIN# SIGNAL

- 1 REMOTE VALVE GROUND : PINK
- 2 LEFT LANE TIER 1 : BROWN
- 3 CENTER LANE TIER 1 : WHITE
- 4 RIGHT LANE TIER 1 : ORANGE
- 5 ANTI-ICE REMOTE VALVE : GRAY
- 6 LEFT LANE TIER 2 : BLUE
- 7 CENTER LANE TIER 2 : GREEN/YELLOW
- 8 RIGHT LANE TIER 2 : YELLOW
- +12 VDC RED
- +12 VDC BROWN/WHITE
- GROUND BLUE/WHITE
- GROUND GREEN/WHITE

LABEL CABLE WITH "TS-8003a ANTI-ICE BOOMS" HEAT SHRINK

ATTACH TO A 10 AMP IGNITION HOT SOURCE

7,8,9

FLY LEADS

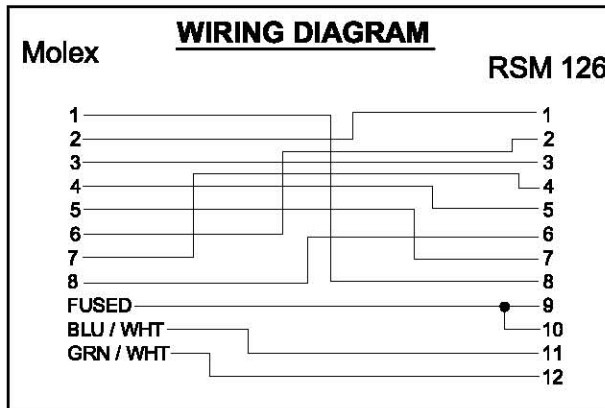
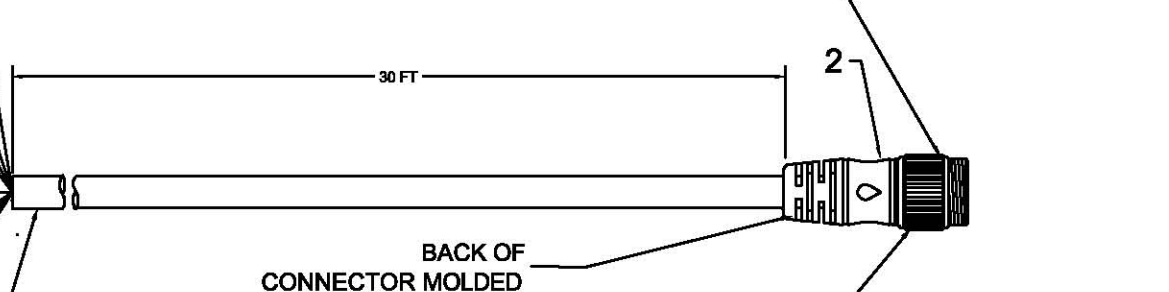

THIS DRAWING IS THE PROPERTY OF CIRUS CONTROLS. THIS IS TO BE CONSIDERED CONFIDENTIAL AND PROPRIETARY NO REPRODUCTION IN WHOLE OR PART WITH OUT PERMISSION IS ALLOWED.

**CIRUS CONTROLS LLC**  
 9210 WYOMING AVE. N. SUITE 200  
 BROOKLYN PARK, MN 55445  
 Phone: (763) 493-9380  
 Fax: (763) 493-9340

REV	DATE	DESCRIPTION
A	-	-
B	-	-
C	-	-
D	-	-
E	-	-

DESIGN: JTM	DRAWN: JTM	AS BUILT: -	PROJECT NUMBER: TS-8003A	SCALE: NONE	DATE: 9-8-08	REV: -
-------------	------------	-------------	--------------------------	-------------	--------------	--------

SPREADER CABLE SYSTEM

ANTI-ICE BOOM CABLE

**B.O.M.**

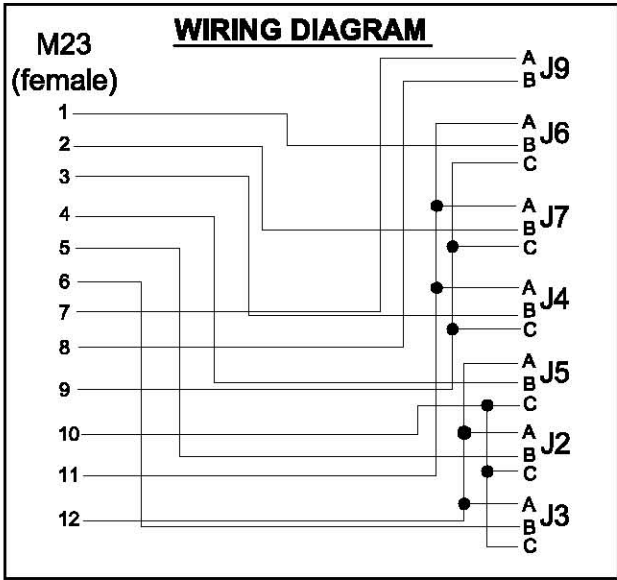

ITEM	QTY	PART NUMBER	DESCRIPTION
1	1	RKM 126-3.3/S90	CABLE OUT TO BOOM VALVES
4	1	RSMC-CC	CAP FOR CABLE TO BODY
10	6	12010717 / WAYTEK 38044	3-PIN WEATHER PACK (SHROUD)
11	1	12010973 / WAYTEK 38042	2-PIN WEATHER PACK (SHROUD)
12	20	12124582 / WAYTEK 30034	PINS WEATHER PACK
13	20	12015289 / WAYTEK 39000	SEAL FOR WEATHER PACK
14	140"	WAYTEK LCN-250	CORRUGATED LOOM .250

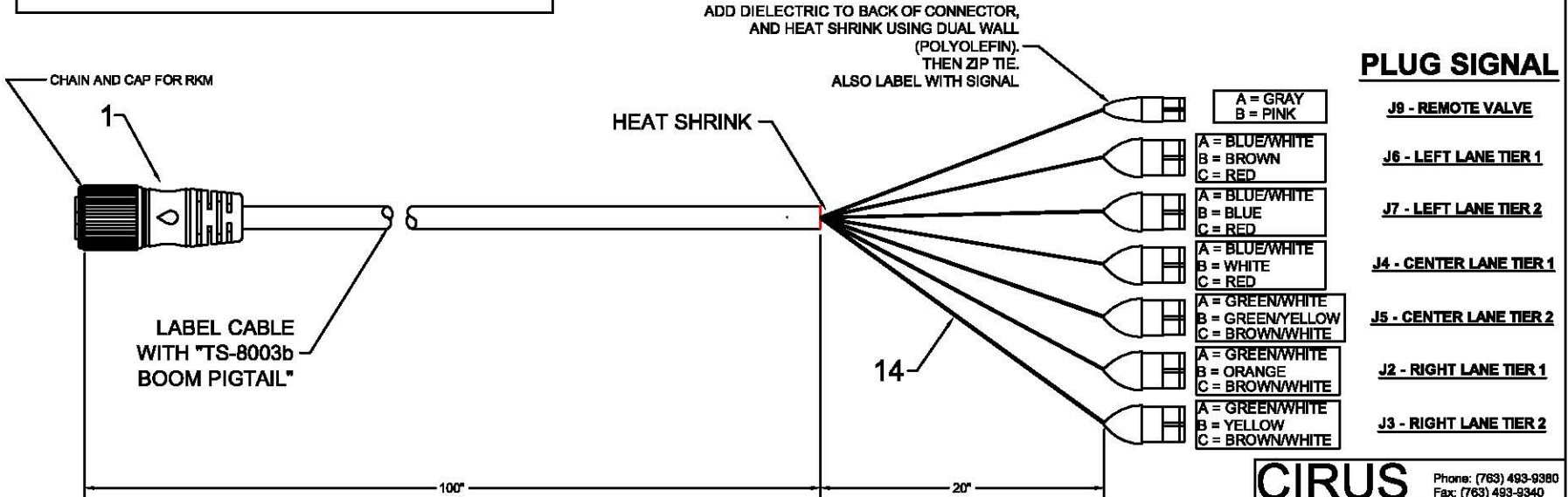

**PLUG SIGNAL**

A = GRAY B = PINK	<b>J9 - REMOTE VALVE</b>
A = BLUE/WHITE B = BROWN C = RED	<b>J6 - LEFT LANE TIER 1</b>
A = BLUE/WHITE B = BLUE C = RED	<b>J7 - LEFT LANE TIER 2</b>
A = BLUE/WHITE B = WHITE C = RED	<b>J4 - CENTER LANE TIER 1</b>
A = GREEN/WHITE B = GREEN/YELLOW C = BROWN/WHITE	<b>J5 - CENTER LANE TIER 2</b>
A = GREEN/WHITE B = ORANGE C = BROWN/WHITE	<b>J2 - RIGHT LANE TIER 1</b>
A = GREEN/WHITE B = YELLOW C = BROWN/WHITE	<b>J3 - RIGHT LANE TIER 2</b>

**CIRUS CONTROLS LLC**  
 9210 WYOMING AVE. N. SUITE 200  
 BROOKLYN PARK, MN 55445  
 Phone: (763) 493-9380  
 Fax: (763) 493-9340

THIS DRAWING IS THE PROPERTY OF CIRUS CONTROLS. THIS IS TO BE CONSIDERED CONFIDENTIAL AND PROPRIETARY NO REPRODUCTION IN WHOLE OR PART WITH OUT PERMISSION IS ALLOWED.

REV	DATE	DESCRIPTION	DESIGNER	DRAWN	AS BUILT	PROJECT NUMBER	SCALE	DATE	REV.
A	-	-	JTM	JTM	-	TS-8003B	NONE	9-8-08	-
B	-	-							
C	-	-							
D	-	-							
E	-	-							

SPREADER CABLE SYSTEM

ANTI-ICE BOOM CABLE

SHT 1 OF 1

**B.O.M.**

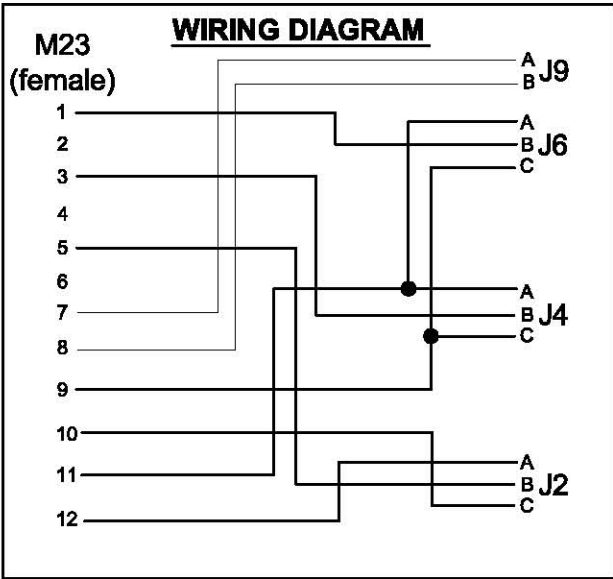

ITEM	QTY	PART NUMBER	DESCRIPTION
1	1	RKM 126-3.3M/S90	CABLE OUT TO BOOM VALVES
4	1	RSMC-CC	CAP FOR CABLE TO BODY
10	3	12010717 / WAYTEK 38044	3-PIN WEATHER PACK (SHROUD)
12	11	12124582 / WAYTEK 30034	PINS WEATHER PACK
13	11	12015289 / WAYTEK 39000	SEAL FOR WEATHER PACK
14	60"	WAYTEK LCN-250	CORRUGATED LOOM .250
11	1	12010973 / WAYTEK 38042	2-PIN WEATHER PACK (SHROUD)

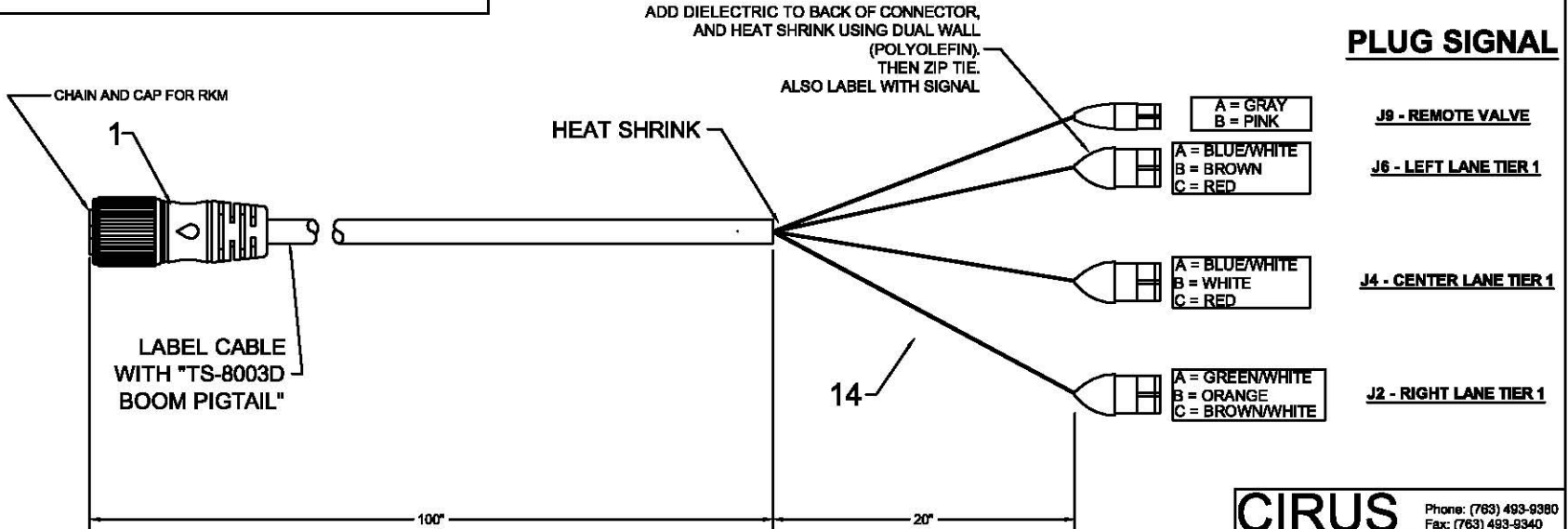

**CIRUS CONTROLS LLC**  
 9210 WYOMING AVE. N. SUITE 200  
 BROOKLYN PARK, MN 55445  
 Phone: (763) 493-9380  
 Fax: (763) 493-9340

THIS DRAWING IS THE PROPERTY OF CIRUS CONTROLS.  
 THIS IS TO BE CONSIDERED CONFIDENTIAL AND  
 PROPRIETARY NO REPRODUCTION IN WHOLE OR PART  
 WITH OUT PERMISSION IS ALLOWED.

REV	DATE	DESCRIPTION
A	-	-
B	-	-
C	-	-
D	-	-
E	-	-

DESIGN: JTM	DRAWN: JTM	AS BUILT: -	PROJECT NUMBER: TS-8003D	SCALE: NONE	DATE: 9-5-08	REV: -
			SPREADER CABLE SYSTEM			
			ANTI-ICE BOOM CABLE			
			SHT 1 OF 1			

# B.O.M.

ITEM	QTY	PART NUMBER	DESCRIPTION
2	1	RSM 126-10M/S90	MAIN ANTI-ICE BOOM TRUNK (TURCK)
3	1	RKMC-CC	CAP FOR MAIN TRUNK
5	1	39-01-2080 (DK#WM3703-ND)	MOLEX 8 PIN
6	11	39-00-0039 (DK#WM2501-ND)	MOLEX TERMINALS
7	1	WAYTEK 46025	15 AMP IN LINE FUSE HOLDER
8	1	WAYTEK 46026	15 AMP IN LINE FUSE HOLDER COVER
9	1	WAYTEK 46256	15 AMP FUSE
10	6	39-00-0041 (WM2500-ND)	MOLEX TERMINALS MALE 18-24 AWG
11	1	39-01-2061 (WM3602-ND)	6 PIN MOLEX PLUG
12	1	39-01-2060 (WM3702-ND)	6 PIN MOLEX RECEPTACLE

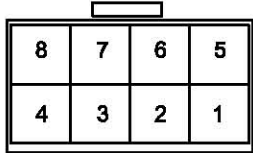

BACK VIEW  
(SIDE PINS ARE INSERTED FROM)

MOLEX 1 (8 PIN)	SIGNAL
1	REMOTE VALVE GROUND : PINK
2	LEFT LANE TIER 1 : BROWN
3	CENTER LANE TIER 1 : WHITE
4	RIGHT LANE TIER 1 : ORANGE
5	ANTHICE REMOTE VALVE : GRAY

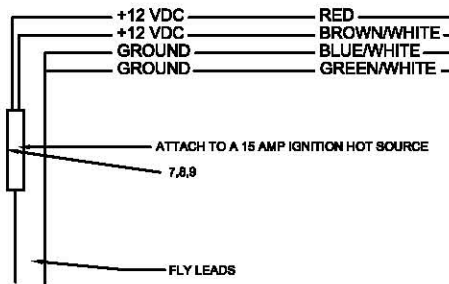

MOLEX 2 (6 PIN) THESE LINES TAP INTO JUMPER BELOW

2	ANTI-ICE SENSOR : BLUE
1	GROUND : GREEN/YELLOW
4	SENSOR POWER(5/12) : YELLOW



MOLEX FEMALE PIN#



Label "Sensor In"

SOLDER AND HEAT SHRINK CONNECTIONS

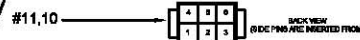

MOLEX MALE PIN#



5 INCHES BETWEEN CONNECTORS

Label "TS-1000 or TS-8000 Sensor Main Trunk Plug In"

THIS DRAWING IS THE PROPERTY OF CIRUS CONTROLS. THIS IS TO BE CONSIDERED CONFIDENTIAL AND PROPRIETARY NO REPRODUCTION IN WHOLE OR PART WITH OUT PERMISSION IS ALLOWED.

30 FT

LABEL CABLE WITH "TS-8004A ANTI-ICE BOOMS" HEAT SHRINK

CHAIN AND CAP FOR RSM

CONNECTOR MUST BE SECURELY MOUNTED TO TRUCK IN PILLLOW BLOCK HANGER

## WIRING DIAGRAM

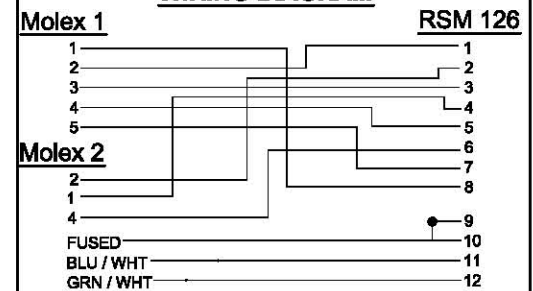

**CIRUS CONTROLS LLC**  
9210 WYOMING AVE. N. SUITE 200  
BROOKLYN PARK, MN 55445  
Phone: (763) 493-9380  
Fax: (763) 493-9340

REV	DATE	DESCRIPTION
A	9-28-09	Added tag labeling & length change on ends tag
B	-	-
C	-	-
D	-	-
E	-	-

DESIGN: JTM    DRAWING: JTM    AS BUILT: -

PROJECT NUMBER	SCALE	DATE	REV
TS-8004A	NONE	9-28-09	A

SPREADER CABLE SYSTEM

ANTI-ICE TRUNK CABLE WITH SENSOR

SHT 1 OF 1

# B.O.M.

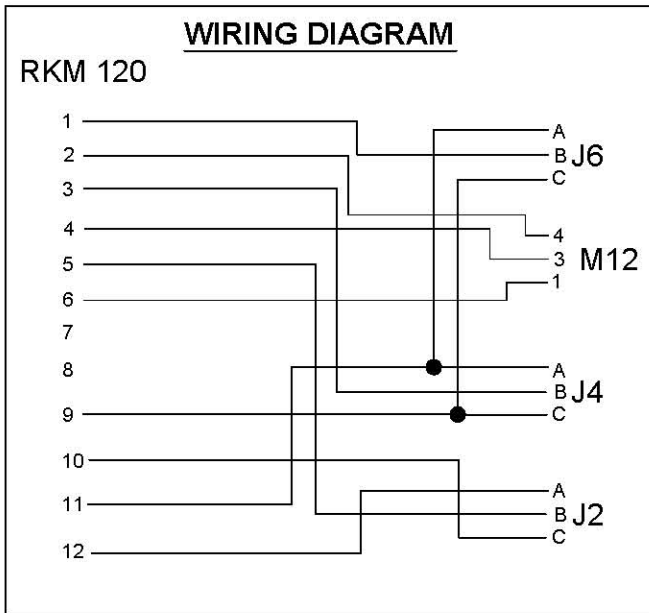

ITEM	QTY	PART NUMBER	DESCRIPTION
1	1	RKM 120-3.3M/S817	CABLE OUT TO BOOM VALVES
4	1	RSMC-CC	CAP FOR CABLE TO BODY
10	3	12010717 / WAYTEK 38044	3-PIN WEATHER PACK (SHROUD)
12	9	12124582 / WAYTEK 30034	PINS WEATHER PACK
13	9	12015289 / WAYTEK 39000	SEAL FOR WEATHER PACK
14	60"	WAYTEK LCN-250	CORRUGATED LOOM .250
	1	RKE 4.5T - .8 - P7X2	FEMALE M12 WITH CABLE

### PLUG SIGNAL

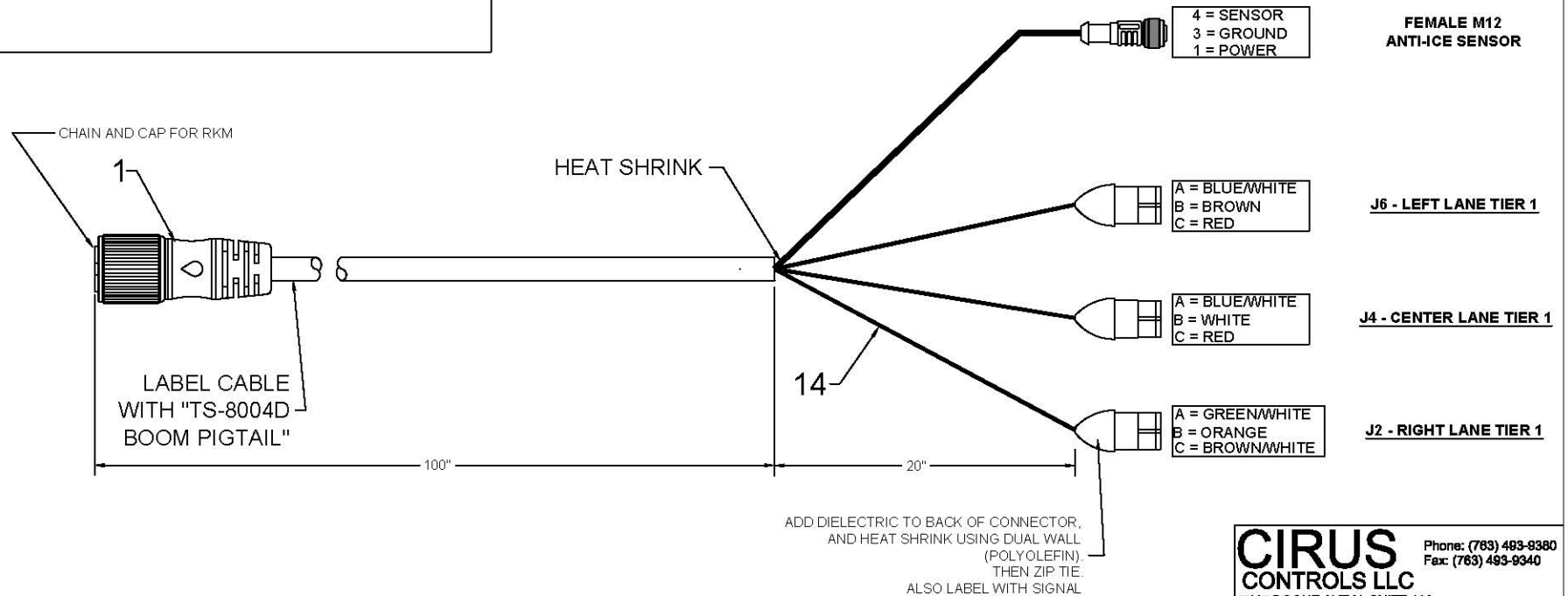

**CIRUS CONTROLS LLC**  
 7165 BOONE AVE N SUITE 190  
 BROOKLYN PARK, MN 55428  
 Phone: (763) 493-9380  
 Fax: (763) 493-9340

THIS DRAWING IS THE PROPERTY OF CIRUS CONTROLS. THIS IS TO BE CONSIDERED CONFIDENTIAL AND PROPRIETARY. NO REPRODUCTION IN WHOLE OR PART WITH OUT PERMISSION IS ALLOWED.

REV	DATE	DESCRIPTION			
A	6-16-10	removed remote valve	SPREADER CABLE SYSTEM ANTHICE BOOM CABLE WITH SENSOR		
B	-	-			
C	-	-			
D	-	-			
E	-	-			
DESIGN:	JTM	DRAWN:	JTM	AS BUILT:	-
PROJECT NUMBER:	TS-8004D	SCALE:	NONE	DATE:	4-29-09
				SHT	1 OF 1
REV.	A				

# B.O.M.

ITEM	QTY	PART NUMBER	DESCRIPTION
1	1	39-01-2060 (Digi-Key #WM3702-ND)	6 PIN MOLEX
2	4	WAYTEK 38045	3 PIN WEATHER PACK (TOWER HALF)
3	6	39-00-0039 (Digi-Key # WM2501-ND)	MOLEX PINS
4	12	WAYTEK 39000	SEAL FOR WEATHER PACK
5	12	WAYTEK 30035	TOWER PINS WEATHER PACK

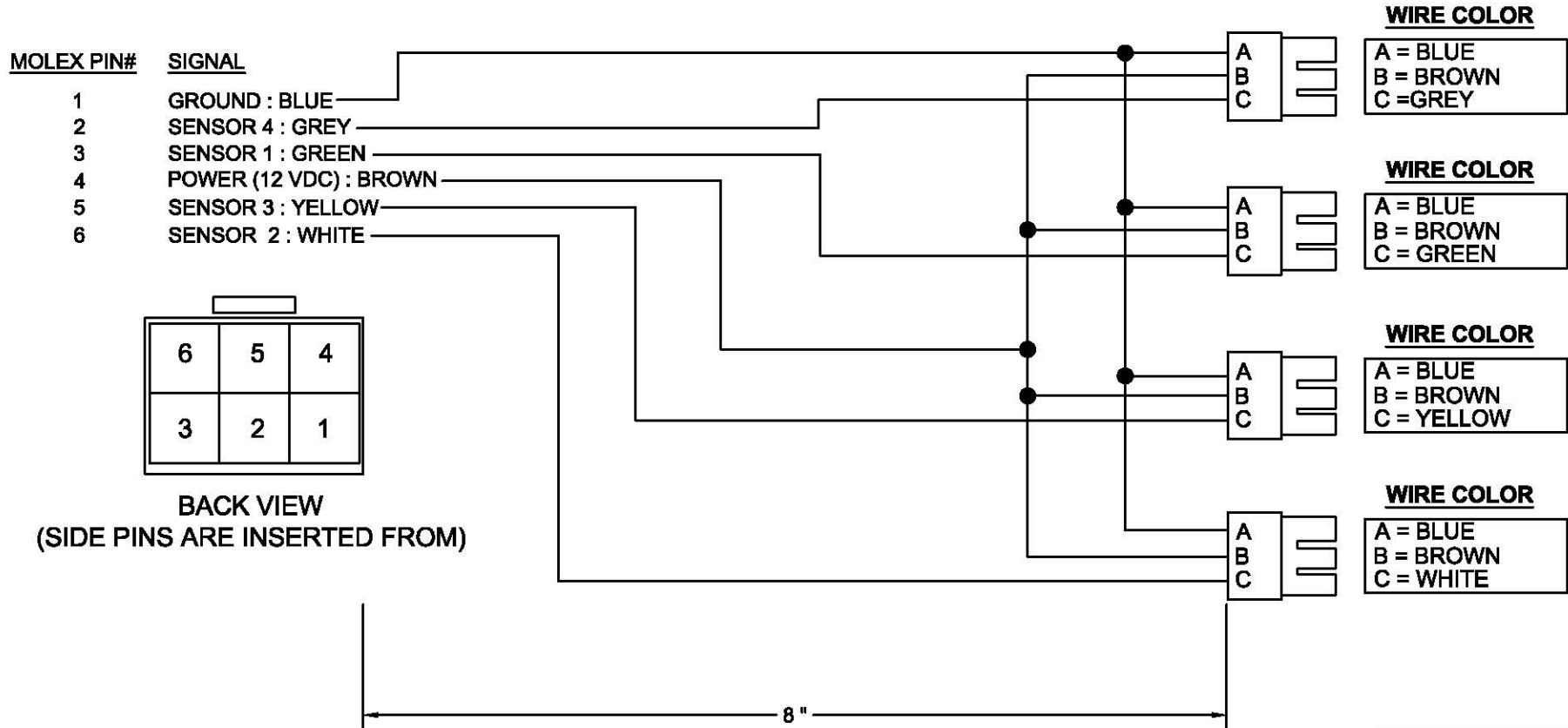

**CIRUS** Phone: (763) 493-9380  
**CONTROLS LLC** Fax: (763) 493-9340  
 9200 WYOMING AVE. N. SUITE 320  
 BROOKLYN PARK, MN 55445

REV	DATE	DESCRIPTION
A	-	-
B	-	-
C	-	-
D	-	-
E	-	-

DESIGN: JTM    DRAWN: JTM    AS BUILT: -

DATA COLLECTION SERIES			
MOLEX TO WEATHER PACK			
PROJECT NUMBER:	SCALE:	DATE:	REV.
DC-1000	NONE	10-18-04	-
SHT 1 OF 1			

THIS DRAWING IS THE PROPERTY OF CIRUS CONTROLS.  
 THIS IS TO BE CONSIDERED CONFIDENTIAL AND  
 PROPRIETARY NO REPRODUCTION IN WHOLE OR PART  
 WITH OUT PERMISSION IS ALLOWED.

# B.O.M.

<u>ITEM</u>	<u>QTY</u>	<u>PART NUMBER</u>	<u>DESCRIPTION</u>
1	1	WAYTEK 38044	3 PIN WEATERPACK (SHROUD HALF)
2	1	WK 4T - 10	FEMALE M12 90 DEGREE AND CABLE (TURCK)
3	3	WAYTEK 30034	SHROUD PINS WEATHER PACK
4	3	WAYTEK 39000	SEAL FOR WEATHER PACK

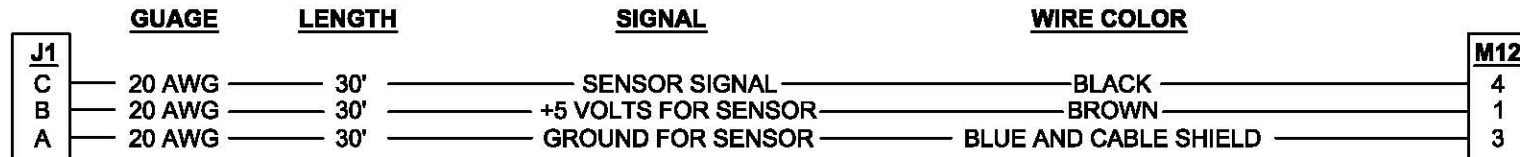

**CIRUS** Phone: (763) 493-9380  
**CONTROLS LLC** Fax: (763) 493-9340  
 9200 WYOMING AVE. N. SUITE 320  
 BROOKLYN PARK, MN 55445

THIS DRAWING IS THE PROPERTY OF CIRUS CONTROLS.  
 THIS IS TO BE CONSIDERED CONFIDENTIAL AND  
 PROPRIETARY NO REPRODUCTION IN WHOLE OR PART  
 WITH OUT PERMISSION IS ALLOWED.

REV	DATE	DESCRIPTION
A	-	-
B	-	-
C	-	-
D	-	-
E	-	-

DESIGN: JTM      DRAWN: JTM      AS BUILT: -

DATA COLLECTION SERIES			
WEATHER PACK TO M12 (90 DEGREES)			
PROJECT NUMBER:	SCALE:	DATE:	REV.
DC-1001	NONE	10-18-04	-
			SHT 1 OF 1



# B.O.M.

<u>ITEM</u>	<u>QTY</u>	<u>PART NUMBER</u>	<u>DESCRIPTION</u>
1	1	WAYTEK 38044	3 PIN WEATERPACK (SHROUD HALF)
2	1	WAYTEK 38045	3 PIN WEATHER PACK (TOWER HALF)
3	3	WAYTEK 30034	SHROUD PINS WEATHER PACK
4	6	WAYTEK 39000	SEAL FOR WEATHER PACK
5	3	WAYTEK 30035	TOWER PINS WEATHER PACK
6	30 FT	ALPHA WIRE 5430/3	3 CONDUCTOR SHIELDED CABLE

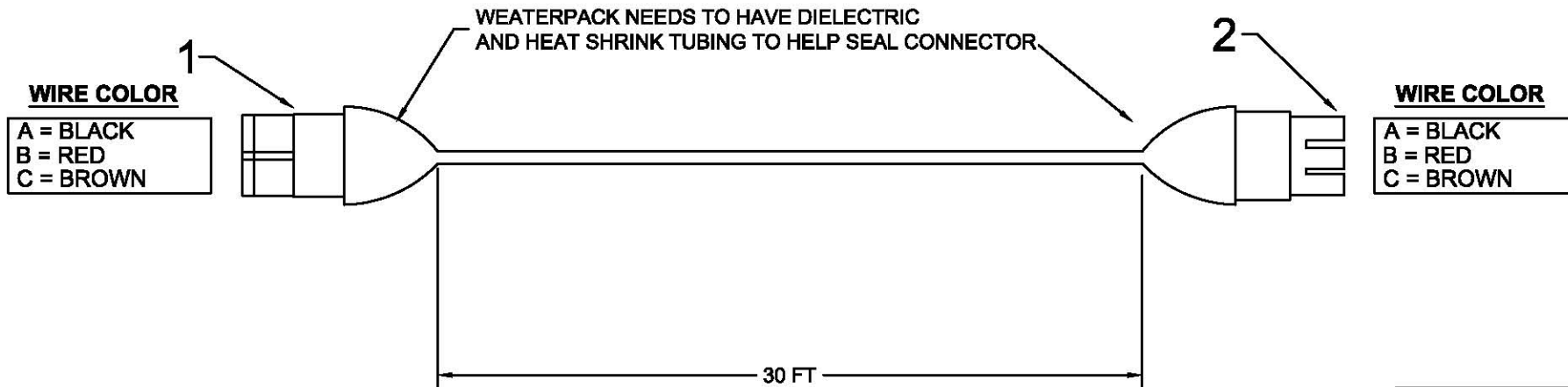
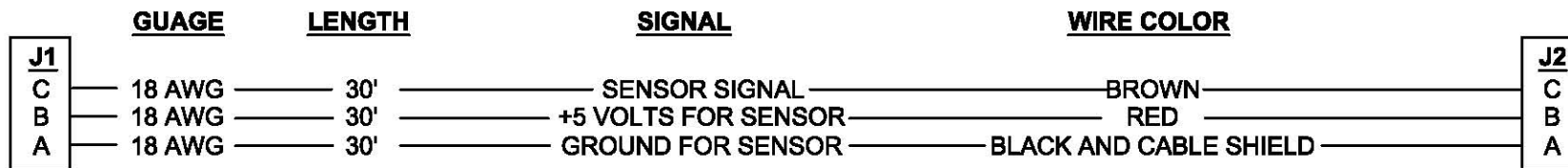

**CIRUS** Phone: (763) 493-9380  
**CONTROLS LLC** Fax: (763) 493-9340  
 9200 WYOMING AVE. N. SUITE 320  
 BROOKLYN PARK, MN 55445

THIS DRAWING IS THE PROPERTY OF CIRUS CONTROLS.  
 THIS IS TO BE CONSIDERED CONFIDENTIAL AND  
 PROPRIETARY NO REPRODUCTION IN WHOLE OR PART  
 WITH OUT PERMISSION IS ALLOWED.

REV	DATE	DESCRIPTION
A	-	-
B	-	-
C	-	-
D	-	-
E	-	-

DESIGN: JTM      DRAWN: JTM      AS BUILT: -

DATA COLLECTION SERIES			
WEATHER PACK TO WEATHER PACK			
PROJECT NUMBER:	SCALE:	DATE:	REV.
DC-1002	NONE	10-18-04	-
SHT 1 OF 1			

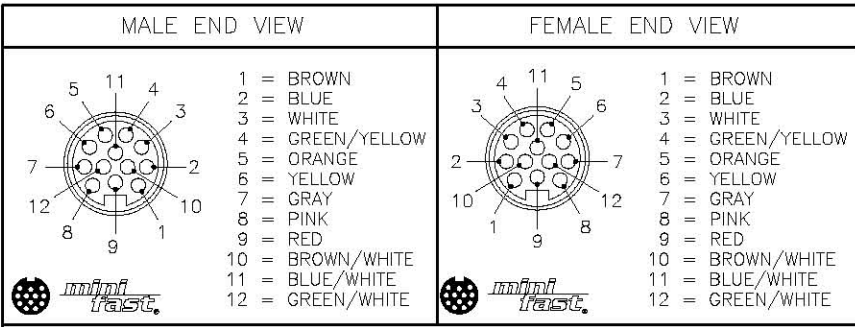

SPECIFICATIONS	
CONTACT CARRIER MATERIAL/COLOR	THERMOPLASTIC PUR/YELLOW
MOLDED HEAD MATERIAL/COLOR	THERMOPLASTIC PUR/YELLOW
CONTACT MATERIAL/PLATING	BRASS/GOLD
COUPLING NUT MATERIAL/PLATING	BRASS/NICKEL
RATED CURRENT [A]	9.0 A
RATED VOLTAGE [V]	300 V
OUTER JACKET MATERIAL/COLOR	PVC/YELLOW
CONDUCTOR INSULATION MATERIAL	PVC
NUMBER OF CONDUCTORS	12x18 AWG
DRAIN/SHIELD	20 AWG/POLYESTER FOIL
TEMPERATURE RATING	-40°C to +105°C (-40°F to +221°F)
PROTECTION CLASS	MEETS NEMA 1,3,4,6P AND IEC IP68

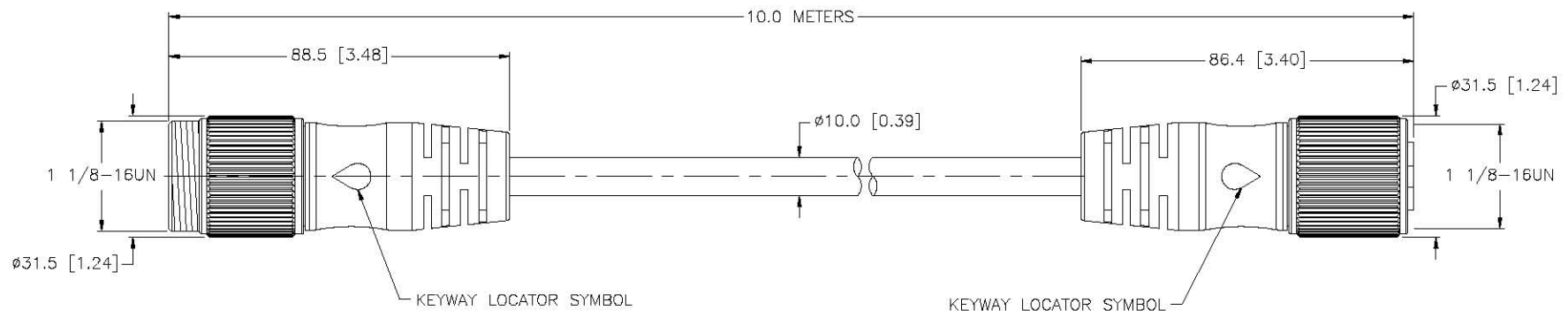

CABLE LENGTH	TOLERANCE
ALL LENGTHS	+ 4% (OR 50mm) OF LENGTH - 0% (OR 0mm) OF LENGTH WHICHEVER IS GREATER
STRIP LENGTH	TOLERANCE
0-7mm	±0.5mm
8-29mm	±1.0mm
30-49mm	±2.0mm
50-89mm	±3.0mm
70-100mm	±4.0mm
OVER 100mm	±5.0mm

NOTES:  
 1. TURCK EQUIVALENT: RSM RKM 120-10M/S817/CS-PVT LABEL  
 2. "/S817" DESIGNATES SPECIAL CABLE WITH CUSTOM WIRING.

SOURCE DRAWING - FOR REFERENCE ONLY

RELATED DOCUMENTS 1. 2. 3. 4.	3RD ANGLE PROJECTION 	THIS DRAWING IS PROPERTY OF TURCK INC. USE OF THIS DOCUMENT WITHOUT WRITTEN PERMISSION IS PROHIBITED.		<b>TURCK INC</b> High Technology Sensors and Automation Controls 3000 CAMPUS DRIVE MINNEAPOLIS, MN 55441 1-800-544-7769 (763) 553-7300 (763) 553-0708 fax turck.com	
	MATERIAL SEE SPECIFICATIONS	TOLERANCES UNLESS OTHERWISE SPECIFIED 0.5 TO 6 ±0.1 6 TO 30 ±0.2 30 TO 200 ±0.3 OVER 200 ±0.4 ANGLES ±1° ALL INCH DIMENSIONS ARE REFERENCE ONLY	DRFT RDS DSGN	DATE 09/28/09 SCALE 1=1.8	DESCRIPTION TS-8103
FINISH SEE SPECIFICATIONS	UNIT OF MEASUREMENT <b>MILLIMETER [ INCH ]</b>	DO NOT SCALE THIS DRAWING		IDENTIFICATION NO. U2-16520	REV A
A DRAWING RELEASE	RDS 09/29/09	BY DATE ECO NO.		FILE: U2-16520	SHEET 1 OF 1

IF A SWITCH IS CONTROLLING DIRECT CAST  
SWITCH # 1026 (511.056)

IF A BLACKTIP IS CONTROLLING DIRECT CAST

OR

IF MAKO JOYSTICK IS CONTROLLING DIRECT CAST

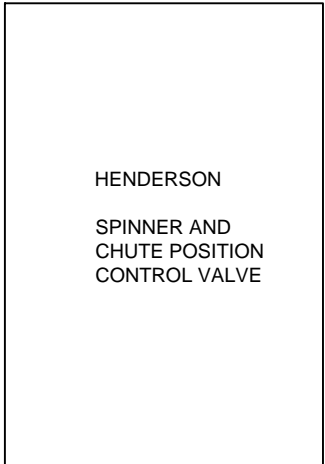
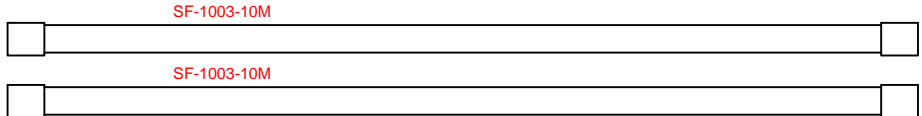

CABLES:  
TS-2100 = 4  
TS-2010 = 3  
SF-1005 = 1  
TS-2005 = 1  
TS-2018 = 1  
DC-1005 = 1

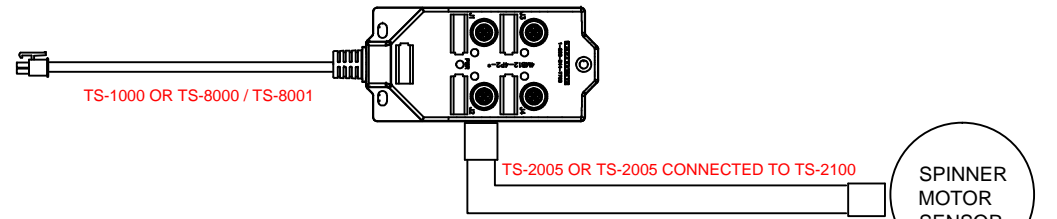
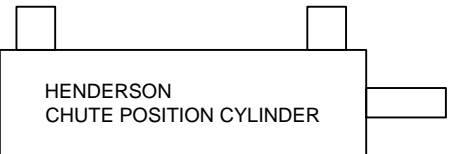
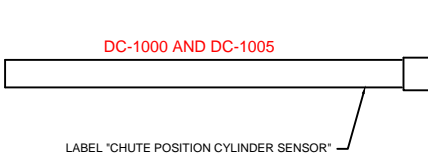
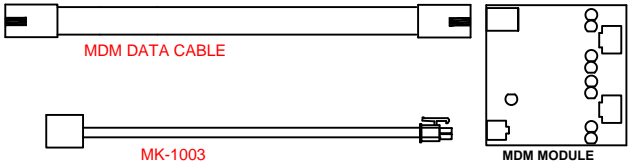
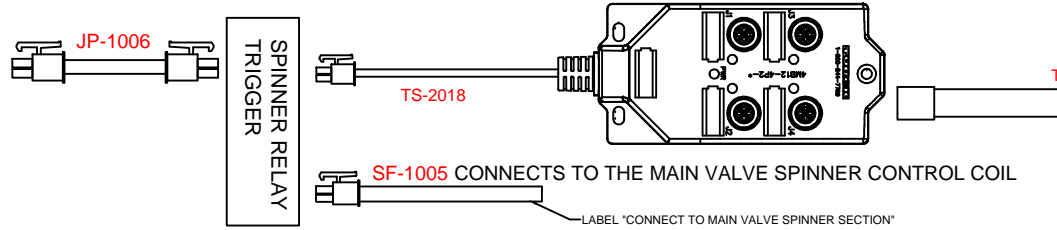
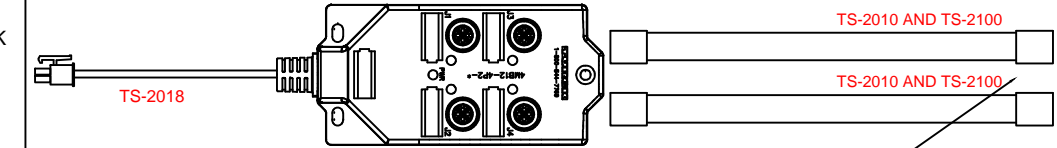

**CIRUS CONTROLS LLC**  
7165 BOONE AVE #190  
BROOKLYN PARK, MN 55445

Phone: (763) 493-9380  
Fax: (763) 493-9340

THIS DRAWING IS THE PROPERTY OF CIRUS CONTROLS. THIS IS TO BE CONSIDERED CONFIDENTIAL AND PROPRIETARY NO REPRODUCTION IN WHOLE OR PART WITH OUT PERMISSION IS ALLOWED.

REV	DATE	DESCRIPTION
A	10-23-12	Added MK-1003 BSS
B	-	-
C	-	-
D	-	-
E	-	-

DESIGN: JTM      DRAWN: JTM      AS BUILT: -

SPREAD SMART RX AND DIRECT CAST			
CABLE OVERVIEW			
PROJECT NUMBER: DIRECT CAST	SCALE: NONE	DATE: 10-12-12 SHT 1 OF 1	REV. A

NOTE: MDM MODULE CAN ACCEPT UP TO 8 SENSORS THROUGH CABLES DC-1001 OR DC-1002.

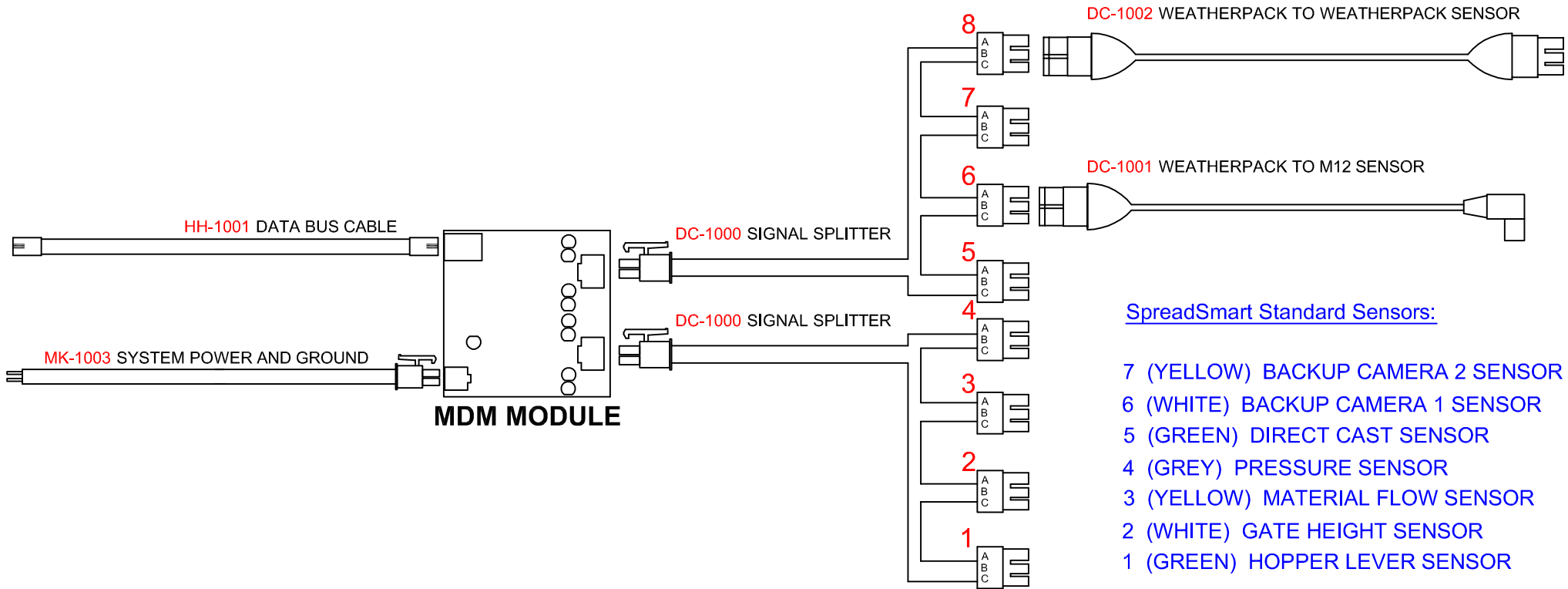

SpreadSmart Standard Sensors:

- 7 (YELLOW) BACKUP CAMERA 2 SENSOR
- 6 (WHITE) BACKUP CAMERA 1 SENSOR
- 5 (GREEN) DIRECT CAST SENSOR
- 4 (GREY) PRESSURE SENSOR
- 3 (YELLOW) MATERIAL FLOW SENSOR
- 2 (WHITE) GATE HEIGHT SENSOR
- 1 (GREEN) HOPPER LEVER SENSOR

**CIRUS** Phone: (763) 493-9380  
**CONTROLS LLC** Fax: (763) 493-9340  
 9200 WYOMING AVE. N. SUITE 320  
 BROOKLYN PARK, MN 55445

THIS DRAWING IS THE PROPERTY OF CIRUS CONTROLS. THIS IS TO BE CONSIDERED CONFIDENTIAL AND PROPRIETARY NO REPRODUCTION IN WHOLE OR PART WITH OUT PERMISSION IS ALLOWED.

REV	DATE	DESCRIPTION
A	11/10/05	Added standard SpreadSmart sensors (MVM)
B	2/21/13	Added Direct Cast and Backup Cameras(BSS)
C	-	-
D	-	-
E	-	-

DESIGN: JTM      DRAWN: JTM      AS BUILT: -

DATA COLLECTION SERIES			
CABLE OVERVIEW			
PROJECT NUMBER: OVERVIEW	SCALE: NONE	DATE: 11-10-05 SHT 1 OF 1	REV. A