



*EZ Spread 2<sup>TM</sup>*

*EZ Spread 3<sup>TM</sup>*

## **Convertible Ground Speed System**

# **Operation Manual**

Limited Warranty.....	2
Revision Log for this Manual .....	4
Package Contents .....	4
Functional Overview – Convertible Capability .....	4
High Current Electric Pre-Wet Systems .....	4
Operating Controls:.....	4
Pre-Delivery System Setup Checklist.....	5
Pre-Delivery .....	5
Step 1 .....	5
Installing the control unit.....	5
Guard Against RF Interference.....	5
Connecting the cabling - Back panel of EZ Spread.....	5
Step 2 – Configure and trim hydraulic channels and “blast”.....	6
Step 3 - Testing the signal outputs.....	8
Trouble Shooting Guide.....	9
Appendix A – Standard System Drawings .....	9
Appendix B – Spare Parts List.....	9
Appendix C – Typical Frequency Settings by Valve Mfg.....	9

## **Limited Warranty**

### **Cirus Controls, LLC.**

#### **What and who is covered?**

This warranty covers all defects in materials or workmanship in your Cirus Controls system under normal use, maintenance and service. This warranty coverage applies only to the original owner and is not transferable.

#### **How long is the warranty period?**

This warranty coverage runs for a period of 1 year from the date of initial installation (or 13 months from date of shipment from Cirus Controls), whichever occurs first. Replacement parts are warranted for the remaining portion of the original warranty period or thirty (30) days from date of shipment from our factory (whichever is greater).

#### **How can you get service?**

Cirus Controls' obligation under this warranty is limited to repairing and/or replacing, at Cirus Controls' option, any part or parts that are determined, by Cirus Controls, to be defective. To be eligible for any claim under this warranty, the owner (or Cirus authorized dealer) must return any defective part(s) to the factory, within the applicable warranty period (as set out above).

#### **What will we do?**

Cirus Controls' may, at its option, elect to grant adjustments in the field through an authorized representative and may thereby elect to waive the requirement that parts be returned to Cirus Controls' factory. The repair or replacement of defective parts under this warranty will be made without charge to the owner except for transportation of the part to our authorized repair location.

#### **What is not covered under this warranty?**

Cirus Controls will not assume any expense or liability for repairs made outside our plant without our prior written consent. We are not responsible for damage to any associated equipment or product and will not be liable for loss of profit or other special damages.

The provisions of this warranty do not apply to any product or parts which have been subject to misuse, negligence or accident, or which have been repaired or altered outside of Cirus Controls' factory in any way (in the judgment of Cirus Controls) so as to affect adversely its performance or reliability. Neither does this warranty apply to normal maintenance service and parts or to normal deterioration due to wear and exposure.

This warranty is expressly in lieu of other warranties, expressed or implied, in fact or by law, including any implied warranty of merchantability of fitness for a particular purpose. The remedies of repair or replacement as set forth are the only remedies under this warranty, Cirus Controls' disclaims any obligations or liability for loss of time, inconvenience, commercial loss or direct consequential, special or incidental damages. This warranty is in lieu of any other obligation or liability of Cirus Controls' of any nature whatsoever by reason of the manufacture, sale, lease or use of such products and Cirus Controls neither assumes, nor authorizes anyone to assume for it, any other obligation or liability in connection with such products.

## Revision Log for this Manual

Rev	Release Date	Description
E	12/30/09	Update Trim Procedure & Frequency settings
F	10/27/10	Spinner trim & jump start;
G	5/14/13	Changed Pass to Pass (Pause)

## Package Contents

A complete *EZ Spread 2 and EZ Spread 3™* control system contains the following items:

- 1) *EZ Spread 2 or EZ Spread 3™* control unit;
- 2) This manual;
- 3) Power cable (MK-1003)
- 4) Remote Blast and Pass (pause) cable (TS 2004)
- 5) Hydraulic control cables (SF-1000) (one each for Auger, Spinner and Aux).

If any of these items are missing, please contact your distributor for replacement parts.

## Functional Overview – Convertible Capability

*EZ Spread 2 and EZ Spread 3™* are manual controllers for hydraulically powered spreading systems, offering independent output control for auger (feed rate), spinner (lane width) and aux (a 3<sup>rd</sup> hydraulic function such as a pre-wet or a cross auger). The EZ Spread “Convertible” can be configured in three ways during set up: a) **Manual only** – no ground speed; b) **Ground speed triggered on/off**; c) **Ground speed oriented on/off**.

## High Current Electric Pre-Wet Systems

The pre-wet channel on *EZ Spread 3™* is rated for a maximum current capacity of 6 amps. If you are using an electric pre-wet pump that is rated for higher source current levels, contact Cirrus Controls for the Electric Pre-Wet Driver accessory module.

## Operating Controls:

**Power On/Off:** turns on power to the complete system (“on” when red is visible on switch).

**Blast /Pass (Pause) Toggle Switch:** this paddle switch allows the operator to turn on the blast or pass (pause) function:

\* “Toggle left” turns blast on. When configured as “on/off,” move toggle left to turn blast off.

When configured as “timed blast,” moving toggle left adds one time increment. “Pass (Pause)” turns blast off.

\* “Toggle right” turns on the “pass (pause)” function and “pauses” the output of all three channels.

**Note: Controller defaults (at power up) with “pass (pause)” function on and pass (pause) indicator light lit.**

**Gnd. Speed On/ Off:** when turned on, the “auger” and the “aux” are normally linked to the motion of the truck. (Spreading will commence when auger &/or Aux dials are set above zero and the truck moves).

**Note:** Proper operation requires the speedometer cable to be hooked up and the “Gnd Speed” switch to be in the “on” position. If the speedometer sensor or cable is not functioning, and the “Gnd Speed” switch is on, the controller receives no signal and the spreader will not output material.

When Gnd Speed switch is in the off position, the ground speed linkage is disabled and the auger, spinner and aux. controls operate without regard for motion of the truck. In the event of a ground speed sensing failure, turning off the “Gnd Speed switch” allows the EZ Spread to be operated manually until the sensor problem is corrected.

**Ground Speed Setup:** *EZ Spread™* controllers include “setup optional” ground speed interaction on the auger and auxiliary output channels. (The spinner channel is not ground speed oriented). No calibration is necessary for the ground speed orientation function. Set up personnel can choose to configure the controller as: a) Manual (no ground speed); b) Ground Speed Triggered on/off: controller actuates when

ground speed switch is “on” and truck is in motion; c) Ground Speed Oriented on/off: controller orients with truck speed when ground speed switch is “on” and truck is in motion; See setup steps for details.

**Feed Rate (Auger) Control:** is a detented trim pot allowing the operator to turn auger off (0 setting) and increase speed to maximum (10 setting). **Caution: auger can operate any time the dial is non-zero.**

**Lane Width (Spinner) Control:** is a detented trim pot allowing the operator to turn the spinner off (0 setting) and/or to uniformly increase its speed to maximum (10 setting). **Caution: the spinner can operate any time the dial is non-zero.**

**Aux Control:** is an optional detented trim pot allowing the operator to turn a third hydraulic function off (0 setting) and/or to uniformly increase its speed to maximum (10 setting). **Caution: the Aux function can operate any time the dial is non-zero.**

**10 Amp Fuse:** a single 10a fuse protects the circuitry and is located in the rear of the unit.

## Pre-Delivery System Setup Checklist

	Description	Completed By/Date
Step 1	Install System and connect cables	
Step 2	Trim hydraulics for all functions	
Step 3	Test the EZ Spread and Outputs	

## Pre-Delivery

### Step 1

To install and run either *EZ Spread™* system, the following steps must be completed.

- 1) Mount the control unit in the truck cab;
- 2) Connect hydraulic control cables, power, remote blast/pass (pause) and any other optional cables;
- 3) Power up the unit, and check functionality of outputs;
- 4) Set the trims;

### Installing the control unit

The control unit of the *EZ Spread™* can be mounted in the flip arm (seat or pedestal mount) or in a stand alone configuration.

### Guard Against RF Interference

Even properly guarded sources of radio frequency (rf) noise can “leak” and interfere with in-cab electronics. Take care when installing radios and radio antenna cable to keep at least 24” spacing between them and any cabling for the *EZ Spread™*.

### Connecting the cabling - Back panel of EZ Spread

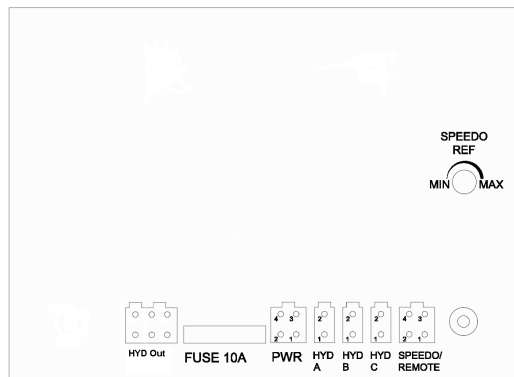

- 1) Connect the SF-1000 hydraulic cables to the labeled ports (Hyd A = Auger, Hyd B = Spinner, Hyd C = Aux). or connect TS-2018 to Hyd Out.
- 2) Connect the TS-2004 speedo cable to the truck to access the speedometer signal. If equipped with a Cirrus Controls plow control, connect remote blast/pass (pause) cable to the Plow control remote blast/pass (pause) cable (optional).
- 3) Finally, connect the MK 1003 power cable to the unit. Check to make sure that the power switch is off before connecting the power leads and then connect power and ground to the cable. **The power cable is normally connected to a 12 volt ignition hot source** or it can be connected to the battery, as the unit is fused, or to a power circuit capable of delivering a minimum of 10 amps.

## Step 2 – Configure and trim hydraulic channels and “blast”

<b>WARNING</b>		<p>Potential for injury due to unexpected startup or movement of mechanical equipment.</p> <p>Unexpected startup or movement of mechanical equipment may cause injury to eyes and extremities.</p> <p>During initial startup and testing, the spreader components may start without warning. Stay clear of the auger, spinner, and liquid nozzles until initial power up and programming are complete.</p>
----------------	---	--

All three hydraulic channels can be trimmed using the controls on the front of the switch panel. **During configuration, the “Ground Speed” function is disabled, so the auger will move while the truck is standing still.** An “ideally trimmed” system will just begin to move at an operating setting of 1 and will reach its maximum speed at a setting of 10. Note that the setting on the dial used during “set up trimming of a function” (below) will not correlate to the settings used during normal operation.

**Note: Changes to configuration are saved when you reach the last step and the blast and pass (pause) LED’s alternately flash. If you terminate your configuration prior to reaching the last step, any and all changes are lost and the controller returns to default settings or to settings saved previously.**

**To enter the configuration mode:** Hold blast switch (left), turn on power, wait for two seconds till blast and pass (pause) LED’s flash, and release Blast. The flashing LED’s show values being set.

a) **Set “Control Frequency” to match the frequency of the coil installed in the truck**

**Indication:** Both blast and pass (pause) LED’s flash slow (2x sec)

**Action:** Set Frequency using auger dial.

(0 = 40, 1 = 60, 2 = 80, 3 = 100, 4 = 120, 5 = 140, 6 = 160, 7=180, 8=220 etc.)

**See Attachment C for frequency by coil manufacturer. Default is set at 120Hz.**

**Accept:** Press **pass (pause)** to confirm chosen value (press **blast** to use previous setting).

b) **Set “Feed Rate” (Auger/Conveyor) Minimum trim level:**

**Indication:** Blast LED will flash slowly (2x sec).

**Action:** Set auger minimum trim using auger dial. Rotate dial until auger just begins to move.

Note: optimal value may be between numbers on the dial.

**Accept:** Press **pass (pause)** to confirm chosen value (press **blast** to use previous setting)

c) **Set “Feed Rate” (Auger/conveyor) Maximum trim level:**

**Indication:** Blast LED will flash quickly (8x sec).

**Action:** Set auger maximum trim using auger dial. Rotate dial until auger speed reaches its maximum. When further rotation of the dial does not change the auger speed, you have reached the maximum speed. Note: optimal value may be between numbers on the dial.

**Accept:** Press **pass (pause)** to confirm chosen value (press **blast** to use previous setting).

**d) Set “Lane Width” (Spinner) Minimum trim level:**

**Indication:** Pass (pause) LED will flash slowly.

**Action:** **Start Auger Moving normally (dial at approximately “4.”)**

Set spinner minimum trim using spinner dial. Rotate dial until spinner moves at “normal rotation speed”.

**Accept:** Press **pass (pause)** to confirm chosen value (press **blast** to use previous setting).

**e) Set “Lane Width” (Spinner) Maximum trim level:**

**Indication:** Pass (pause) LED will flash quickly.

**Action:** **Leave Auger Moving as before**

Set spinner maximum trim using spinner dial. Rotate dial until spinner speed reaches its maximum. When further rotation of the dial does not change the spinner speed, you have reached the maximum speed possible. Note: optimal value may be between numbers on the dial.

**Accept:** Press **pass (pause)** to confirm chosen value (press **blast** to use previous setting).

**\*\*\*\* Return Auger Dial to “0” \*\*\*\***

**Note: on systems equipped with three dials, set min and max trims for the aux channel. On two dial systems, the system automatically goes to step (h).**

**f) Set “Aux” Minimum trim level:**

**Indication:** Aux LED will flash slowly.

**Action:** Set aux min trim using aux dial. Rotate dial until aux just begins to move. Note: optimal value may be between numbers on the dial.

**Accept:** Press **pass (pause)** to confirm chosen value (press **blast** to use previous setting).

**g) Set “Aux” Maximum trim level:**

**Indication:** Aux LED will flash quickly.

**Action:** Set aux max trim using aux dial. Rotate dial until aux speed reaches its maximum. When further rotation of the dial does not change the aux speed, you have reached the maximum speed possible. Note: optimal value may be between numbers on the dial.

**Accept:** Press **pass (pause)** to confirm chosen value (press **blast** to use previous setting).

**h) Set Blast timer (or on/off):**

**Indication:** Blast and Pass (Pause) flash quickly.

**Action:** Set blast using auger dial (each mark = 2 sec, **0=on/off**, 2 = 4 sec, 4 = 8 sec, 8=16 sec, etc.)

**Note: to configure Blast as “on/off” set dial at zero during this step.**

**Accept:** Press **pass (pause)** to confirm chosen value (press **blast** to use previous setting).

**i) Set “Ground Speed Mode”**

**Indication:** Blast, Pass (Pause) (& Aux) “blip”.

**Action:** Set ground speed mode using spinner dial ( **0=manual only** - Gnd Speed switch disabled; **5 = Ground Speed Triggered** (on/off with switch); **10 = Ground speed oriented** (on/off with switch).

**Accept:** Press **pass (pause)** to confirm chosen value (press **blast** to use previous setting).

**j) Configuration is complete**

**Indication:** Blast and Pass (Pause) will flash in an alternate sequence (left, right etc).

**Accept:** Cycle power to start spreader in normal mode.

### Step 3 - Testing the signal outputs

<b>WARNING</b>	 <p>Potential for injury due to unexpected startup or movement of mechanical equipment.</p> <p>Unexpected startup or movement of mechanical equipment may cause injury to eyes and extremities.</p> <p>During initial startup and testing, the spreader components may start without warning. Stay clear of the auger, spinner, and liquid nozzles until initial power up and programming are complete.</p>
----------------	--

- 1) Turn on the system with the truck running.
- 2) Turn “off” the ground speed trigger switch and set the auger dial to any “non-zero” setting. The auger will engage and the LED on the valve junction box will light.
- 3) Turn “on” the “Gnd Speed” switch, the auger will stop running and the VJB LED will turn off.
- 4) Drive truck slowly forward. Verify that auger starts turning when truck runs above 2 mph. If not, adjust speedo reference trim pot (back panel) until auger responds to truck motion.
- 5) Final trimming of auger motion can be accomplished after ground speed signal is validated.
- 6) To adjust one or more trim settings, hold blast, turn on power, wait for two seconds, then release blast. The spreader will now enter configuration mode as before. When entering the configuration mode, the spreader retains the settings made in step 2. You can change only the settings you wish to change, by pressing blast to retain old settings. To accept new settings, press “pass (pause)” after making adjustments.



## Trouble Shooting Guide

Complaint	Cause (s)	Correction (s)
<b>Set Up Issues</b>		
Power Isn't On	a) Master Power Off; b) Fuse is blown; c) Bad Power or Ground connection;	a) Turn on power; b) Replace Fuse c) Verify power/ground connections.
EZ Spread cuts out or acts strange;	Low power supply voltage from truck battery/alternator;	Minimum truck voltage must be > 12.0 volts;
Auger or Spinner Doesn't Move (truck is stationary)	a) PTO not engaged; b) Hydraulics not functioning;  c) Electrical connection failure;  d) EZ Spread power off; e) "Pass (Pause)" is engaged and LED lit	a) Engage PTO; b) Verify Hydraulics: actuate plow or hoist; manually operate using manual over-ride on valve;  c) Check LED at coil connection and at valve junction box; Repair cable connections; d) Check wiring connections; e) Select "pass (pause)" switch to begin spreading;
Auger doesn't move when truck starts;	a) Ground speed trigger not on; b) Ground Speed signal not received by controller due to reference error;	a) Turn on ground speed trigger; b) Adjust Speedo reference trim pot on rear of controller until signal is functioning normally.
Spinner slows down or stops	Minimum trim for spinner too low; Hydraulic pressure in spinner circuit is below pressure compensator;	a) Re-trim spinner to a higher minimum trim level. b) Increase pressure in spinner circuit; Use spool with lower flow rating;

## Appendix A – Standard System Drawings

## Appendix B – Spare Parts List

Part #	Description
021007.2	EZ 2 knob spreader control unit without enclosure;
021007.3	EZ 3 knob spreader control unit without enclosure;
MK 1003	12V power cable;
TS 2004	Speedometer signal and remote blast and pass (pause) cable;
SF 1000	Hydraulic cable; used for Hyd A, B and C outputs;
000203	10amp 32v fuse.

## Appendix C – Typical Frequency Settings by Valve Mfg

Brand Valve (prewet systems)	100 Hz
Husco – Section Valves –	100 Hz
Hydra Force (Cirrus manifold)	220 Hz
Parker -	60 Hz
Rexroth (MP18)	180 Hz
Sauer Dan Foss - PVG32	80 Hz

# EZ SPREAD MOUNTED IN CAB ARMREST/STANDALONE

## POWER CABLE

**MK-1003** POWER CABLE

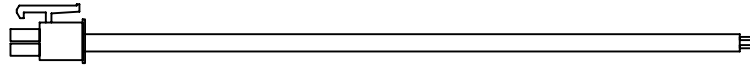

## HYDRAULIC DRIVE CABLES (up to 3)

**SF-1000** HYDRAULIC DRIVE CABLE

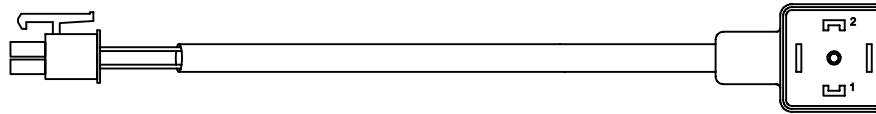

**SF-1000** TERMINATED WITH DIN  
(HIRSHMAN CONNECTOR) (TYPICAL MHV CONNECTOR)

**SF-1002** HYDRAULIC DRIVE CABLE

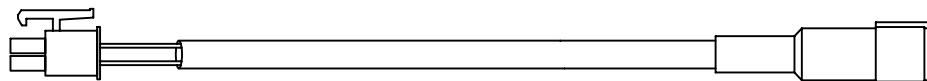

**SF-1002** TERMINATED WITH ITT CANNON  
(C2 CONNECTOR) (TYPICAL MP18/REXROTH CONNECTOR)

**SF-1003** HYDRAULIC DRIVE CABLE

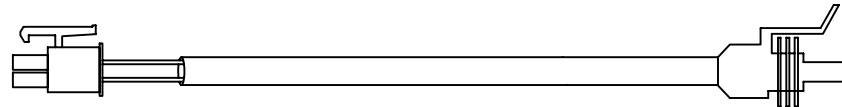

**SF-1003** TERMINATED WITH WEATHERPACK  
(TOWER HALF CONNECTOR)

## SPEEDO/REMOTE CABLE

**TS-2004** SPEEDO/REMOTE CABLE

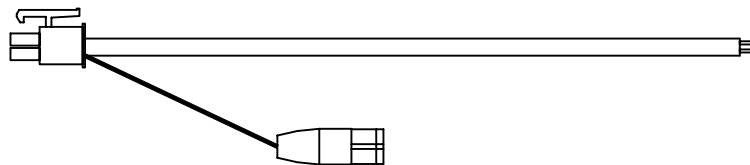

**CIRUS** Phone: (763) 493-9380  
**CONTROLS LLC** Fax: (763) 493-9340  
 9200 WYOMING AVE. N. SUITE 320  
 BROOKLYN PARK, MN 55445

THIS DRAWING IS THE PROPERTY OF CIRUS CONTROLS.  
 THIS IS TO BE CONSIDERED CONFIDENTIAL AND  
 PROPRIETARY NO REPRODUCTION IN WHOLE OR PART  
 WITH OUT PERMISSION IS ALLOWED.

REV	DATE	DESCRIPTION	SPREADER CABLE SYSTEM										
A	12/20/04	Added SF-1002 cable	SWORDFISH (EZ 2004) CABLE OVERVIEW										
B	01/07/05	Added SF-1003 cable											
C	-	-											
D	-	-											
E	-	-											
DESIGN:	MVM	DRAWN:	MVM	AS BUILT:	-	PROJECT NUMBER:	EZ CABLES	SCALE:	NONE	DATE:	01-07-05	REV:	B
											SHT	1 OF 1	

# B.O.M.

QTY	PART NUMBER	DESCRIPTION
1	39-01-2020	MOLEX RECEPTACLE 2 PIN
2	39-00-0039	MOLEX TERMINALS FEMALE 18-24 AWG
18 FT	???	18 AWG, 2 COND. SVO CABLE or SIMILAR
1	43650	DIN CONNECTOR WITH INTEGRAL LED



BACK VIEW  
(SIDE PINS ARE INSERTED FROM)

MOLEX PIN#	SIGNAL	DIN CONNECTOR PIN#
2	DRIVE : BLACK (18 AWG)	1
1	RETURN : WHITE (18AWG)	2

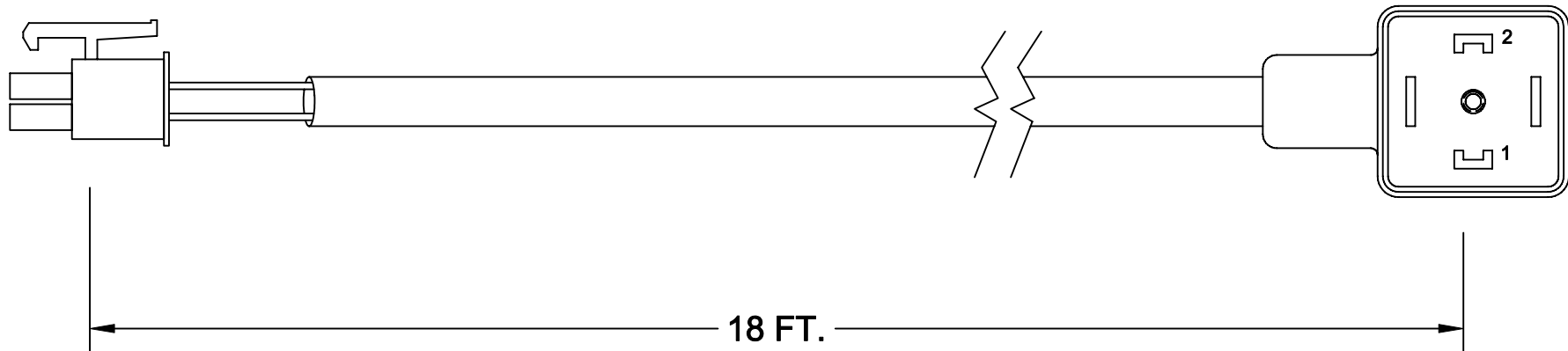

**CIRUS** Phone: (763) 493-9380  
**CONTROLS LLC** Fax: (763) 493-9340  
 9200 WYOMING AVE. N. SUITE 320  
 BROOKLYN PARK, MN 55445

THIS DRAWING IS THE PROPERTY OF CIRUS CONTROLS.  
 THIS IS TO BE CONSIDERED CONFIDENTIAL AND  
 PROPRIETARY NO REPRODUCTION IN WHOLE OR PART  
 WITH OUT PERMISSION IS ALLOWED.

REV	DATE	DESCRIPTION	SWORDFISH SPREADER CABLE SYSTEM										
A	-	-	EZ SPREAD HYDRAULIC CABLE										
B	-	-											
C	-	-											
D	-	-											
E	-	-											
DESIGN:	MVM	DRAWN:	MVM	AS BUILT:	-	PROJECT NUMBER:	SF-1000	SCALE:	NONE	DATE:	04-07-04	REV.:	-
											SHT 1 OF 1	-	

# B.O.M.

## NOTES:

1. CABLE TO BE BAGGED AND THE BAG LABELED WITH "TS-2004"

QTY	PART NUMBER	DESCRIPTION
1	39-01-2040 (Digi-Key WM3701-ND)	MOLEX RECEPTACLE 4 PIN
4	39-00-0039 (Digi-Key WM2501-ND)	MOLEX TERMINALS FEMALE 18-24 AWG
12 FT	AUTOMOTIVE GRADE	2 CONDUCTOR 18 AWG CABLE
1	12010973	2-PIN WEATHER PACK (SHROUD)
2	12089040	PINS FOR WEATHER PACK
2	12015323	SEAL FOR WEATHER PACK

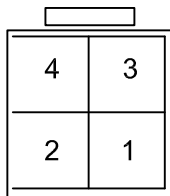
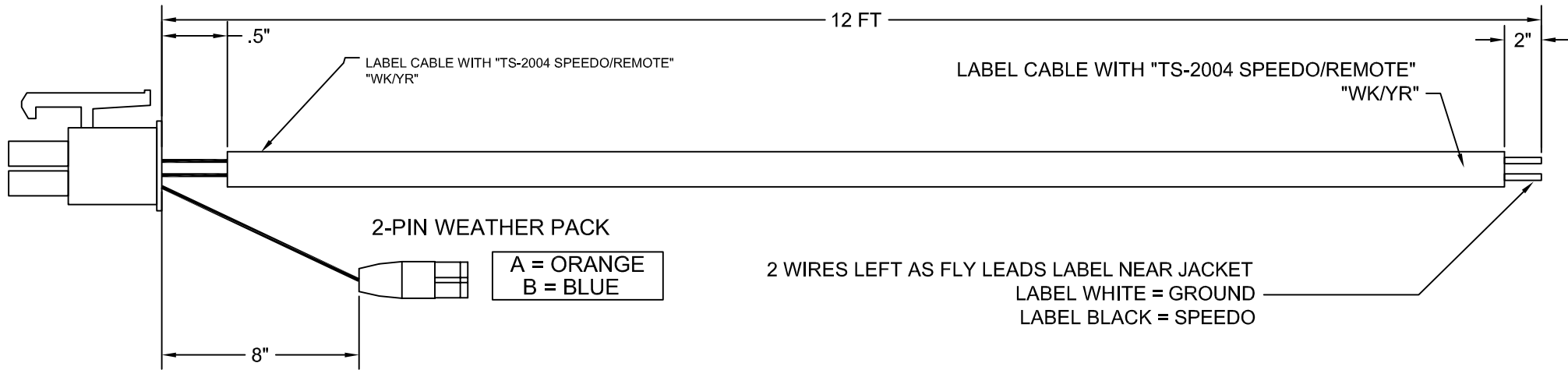

MOLEX PIN#	SIGNAL
1	GROUND : WHITE (18AWG)
2	REMOTE PASS (PAUSE) : BLUE
3	SPEEDO : GREEN OR BLACK
4	REMOTE BLAST (MORAY = REMOTE TRIGGER) : ORANGE

BACK VIEW  
(SIDE PINS ARE INSERTED FROM)

**Cirus Controls**  
9200 Wyoming Ave. N. Suite 320  
Brooklyn Park, MN 55445  
Tel: (763) 493-9380  
Fax: (763) 493-9340

THIS DRAWING IS THE PROPERTY OF CIRUS CONTROLS  
THIS IS TO BE CONSIDERED CONFIDENTIAL AND NO  
REPRODUCTION IN WHOLE OR PART WITH OUT  
PERMISSION IS ALLOWED.

REV	DATE	DESCRIPTION
A	4-20-07	LABELLED OTHER END OF CABLE
B	4-26-07	CHANGES TO CABLE
C	12-8-09	ADDED MORAY TRIGGER
D	10-2-10	ADDED THE WORD 'PAUSE' AFTER 'PASS'
E	-	-

DESIGN: JTM	DRAWN: JTM	AS BUILT: -	PROJECT NUMBER: TS-2004	SCALE: NONE	DATE: 12-8-09	REV. C
			SPREADER CABLE SYSTEM		SPEEDO AND REMOTE BLAST/PASS	
					SHT 1 OF 1	

# B.O.M.

**NOTES:**

1. ALL WIRE JACKETS AND CORRUGATED LOOM NEED TO HAVE MINIMUM MELTING POINT OF 250 DEGREES F.
2. MINIMUM WIRE JACKET DIAMETER .060" AND MAXIMUM DIAMETER .125"
3. ALL WIRE PRINTED EVERY 12 INCHES WITH SIGNAL NAME
4. WEATHER PACK CONNECTIONS NEED DIELECTRIC, AND HEAT SHRINK.

ITEM	QTY	PART NUMBER	DESCRIPTION
1	1	39-01-2020	MOLEX RECEPTACLE 2 PIN
2	2	39-00-0039	MOLEX TERMINALS FEMALE 18-24 AWG
3	1	WAYTEK 38043	2-PIN WEATHERPACK (TOWER HALF)
4	2	WAYTEK 30035 (20-18 AWG)	SOCKET FEMALE WEATHERPACK
5	2	WAYTEK 39000	SEAL FOR WEATHER PACK
6	1	LCN-250 (WAYTEK)	CORRUGATED LOOM, 0.25 X 29 FEET

CRIMP END	GUAGE	LENGTH	SIGNAL	WIRE COLOR	CRIMP END
J1 2	PIN 66361-4	18 AWG	PRE-WET VALVE CONTROL (PWM)	WHITE / GREEN	FEMALE 30035
1	PIN 66361-4	18 AWG	PRE-WET VALVE GROUND	WHITE	FEMALE 30035

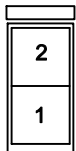

BACK VIEW  
(SIDE PINS ARE INSERTED FROM)

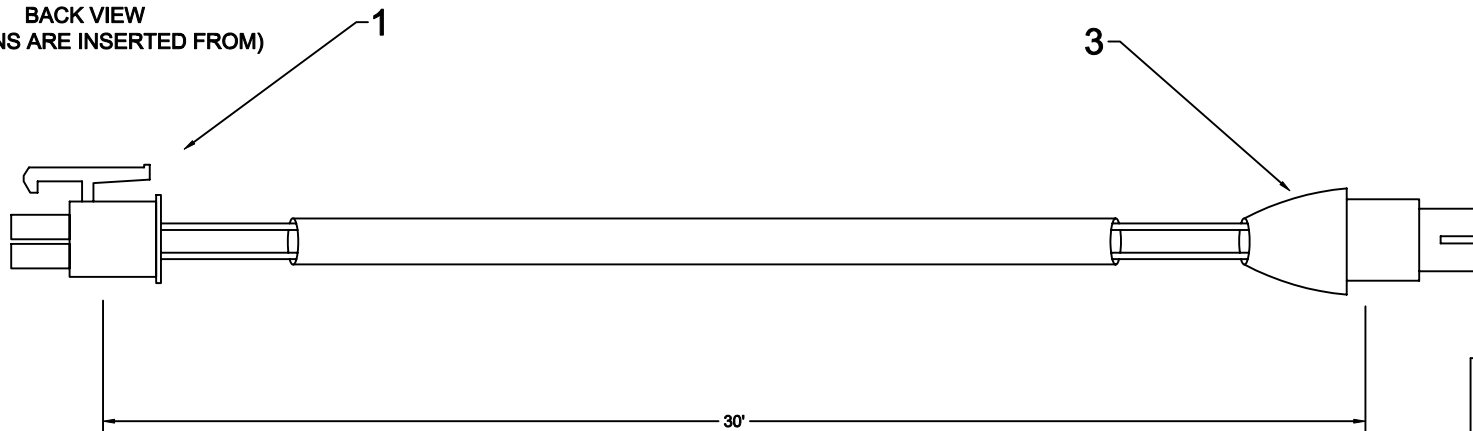

**CIRUS** Phone: (763) 493-9380  
**CONTROLS LLC** Fax: (763) 493-9340  
 9200 WYOMING AVE. N. SUITE 320  
 BROOKLYN PARK, MN 55445

THIS DRAWING IS THE PROPERTY OF CIRUS CONTROLS.  
 THIS IS TO BE CONSIDERED CONFIDENTIAL AND  
 PROPRIETARY NO REPRODUCTION IN WHOLE OR PART  
 WITH OUT PERMISSION IS ALLOWED.

REV	DATE	DESCRIPTION
A	-	-
B	-	-
C	-	-
D	-	-
E	-	-

DESIGN: MVM	DRAWN: MVM	AS BUILT: -	PROJECT NUMBER: SF-1001	SCALE: NONE	DATE: 07-08-04	REV: -
-------------	------------	-------------	-------------------------	-------------	----------------	--------

SPREADER CABLE SYSTEM  
 30' PRE-WET DRIVE CABLE

# B.O.M.

QTY	PART NUMBER	DESCRIPTION
1	39-01-2020	MOLEX RECEPTACLE 2 PIN
2	39-00-0039	MOLEX TERMINALS FEMALE 18-24 AWG
18 FT	???	18 AWG, 2 COND. SVO CABLE or SIMILAR
1	317-1398-000	SURESEAL BOOT
1	120-1804-000	SURESEAL RECEPTACLE
1	031-1267-001	SURESEAL TIN SOCKET
1	030-2196-001	SURESEAL TIN PIN

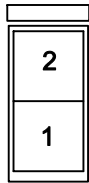

BACK VIEW  
(SIDE PINS ARE INSERTED FROM)

MOLEX PIN#	SIGNAL	C2 CONNECTOR PIN#
2	DRIVE : BLACK (18 AWG)	1
1	RETURN : WHITE (18AWG)	2

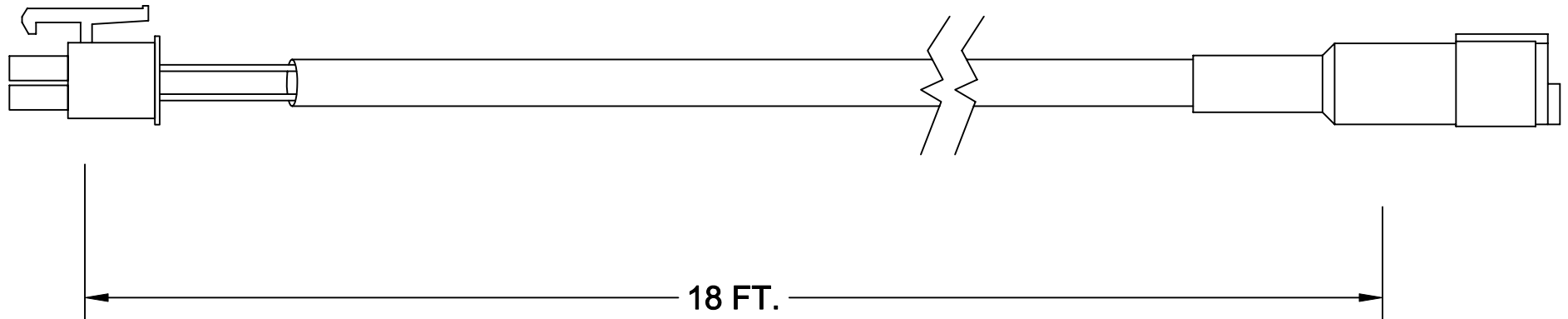

THIS DRAWING IS THE PROPERTY OF CIRUS CONTROLS.  
THIS IS TO BE CONSIDERED CONFIDENTIAL AND  
PROPRIETARY NO REPRODUCTION IN WHOLE OR PART  
WITH OUT PERMISSION IS ALLOWED.

REV	DATE	DESCRIPTION	CIRUS CONTROLS LLC			
A	-	-	9200 WYOMING AVE. N. SUITE 320			
B	-	-	BROOKLYN PARK, MN 55445			
C	-	-	SWORDFISH SPREADER CABLE SYSTEM			
D	-	-	EZ SPREAD HYDRAULIC CABLE			
E	-	-	DESIGN: MVM	DRAWN: MVM	AS BUILT: -	PROJECT NUMBER: SF-1002
			SCALE: NONE	DATE: 12-20-04	REV. -	Phone: (763) 493-9380
					SHT 1 OF 1	Fax: (763) 493-9340

# B.O.M.

QTY	PART NUMBER	DESCRIPTION
1	39-01-2020	MOLEX RECEPTACLE 2 PIN
2	39-00-0039	MOLEX TERMINALS FEMALE 18-24 AWG
18 FT	???	18 AWG, 2 COND. SVO CABLE or SIMILAR
1	38043 (WAYTEK)	WEATHERPAK 2 PIN (TOWER HALF)
2	30035 (WAYTEK)	TOWER TERMINALS 20-18 AWG
2	39000 (WAYTEK)	WEATHERPAK WIRE SEALS



**BACK VIEW**  
(SIDE PINS ARE INSERTED FROM)

MOLEX PIN#	SIGNAL	WEATHERPAK CONNECTOR PIN#
1	RETURN : WHITE (18AWG)	1
2	DRIVE : BLACK (18 AWG)	2

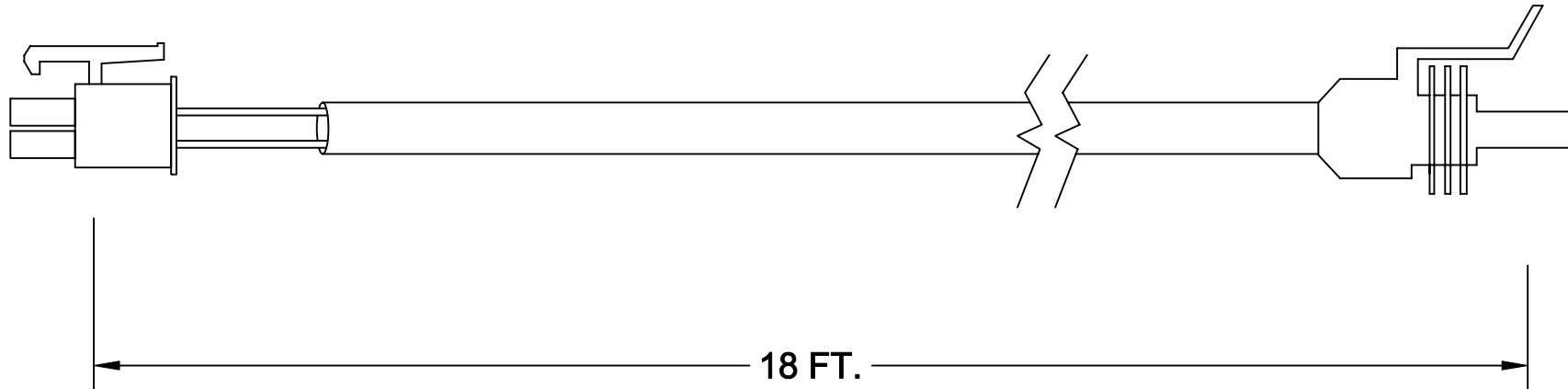

**CIRUS** Phone: (763) 493-9380  
**CONTROLS LLC** Fax: (763) 493-9340  
 9200 WYOMING AVE. N. SUITE 320  
 BROOKLYN PARK, MN 55445

THIS DRAWING IS THE PROPERTY OF CIRUS CONTROLS.  
 THIS IS TO BE CONSIDERED CONFIDENTIAL AND  
 PROPRIETARY NO REPRODUCTION IN WHOLE OR PART  
 WITH OUT PERMISSION IS ALLOWED.

REV	DATE	DESCRIPTION											
A	-	-	SWORDFISH SPREADER CABLE SYSTEM										
B	-	-	EZ SPREAD HYDRAULIC CABLE										
C	-	-											
D	-	-											
E	-	-											
DESIGN:	MVM	DRAWN:	MVM	AS BUILT:	-	PROJECT NUMBER:	SF-1003	SCALE:	NONE	DATE:	01-07-05	REV.	-
												SHT 1 OF 1	-

# B.O.M.

MOLEX PIN#	SIGNAL	METRI-PACK 150 PIN#
2	DRIVE : BLACK (18 AWG)	1
1	RETURN : WHITE (18AWG)	2

QTY	PART NUMBER	DESCRIPTION
1	39-01-2020	MOLEX RECEPTACLE 2 PIN
2	39-00-0039	MOLEX TERMINALS FEMALE 18-24 AWG
18 FT	???	18 AWG, 2 COND. SVO CABLE or SIMILAR
1	38201 (waytek)	FEMALE METRI-PACK 150 2 pin
2	31077 (waytek)	FEMALE TERMINALS 16-18 AWG
1	38202 (waytek)	TPA LOCK
2	39008 (waytek)	CABLE SEALS

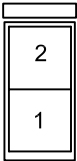

BACK VIEW  
(SIDE PINS ARE INSERTED FROM)

ADD DIELECTRIC TO BACK OF CONNECTOR,  
AND HEAT SHRINK USING DUAL WALL  
(POLYOLEFIN).  
THEN ZIP TIE.

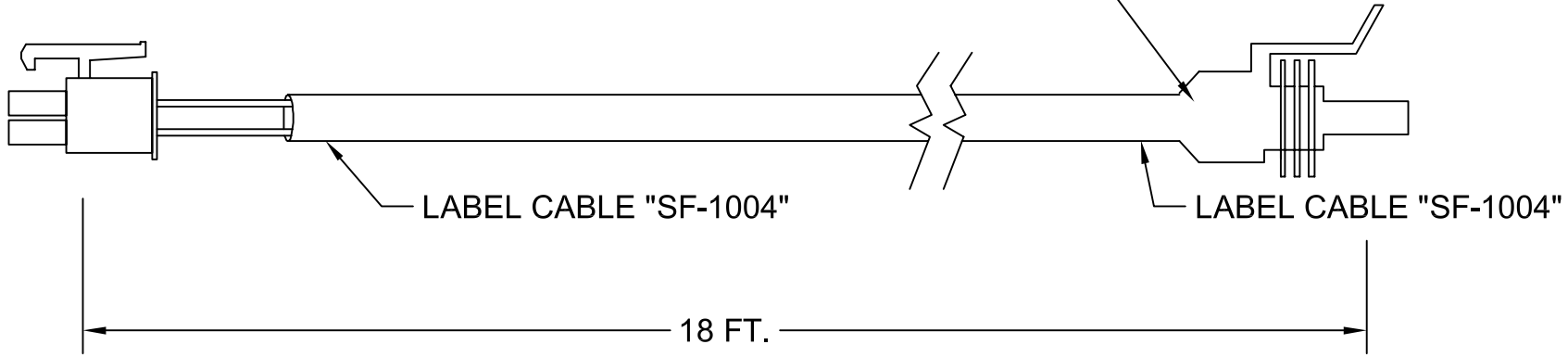

NOTES:  
1. TWIST TIE CABLES IN A LOOP

# SF-1004

THIS DRAWING IS THE PROPERTY OF CIRUS CONTROLS.  
THIS IS TO BE CONSIDERED CONFIDENTIAL AND  
PROPRIETARY NO REPRODUCTION IN WHOLE OR PART  
WITH OUT PERMISSION IS ALLOWED.

**CIRUS** Phone: (763) 493-9380  
**CONTROLS LLC** Fax: (763) 493-9340  
 9210 WYOMING AVE. N. SUITE 200  
 BROOKLYN PARK, MN 55445

REV	DATE	DESCRIPTION
A	11-18-06	ADDED NOTES FOR LABEL AND TWIST TIE
B	4-20-07	ADDED LABELS
C	3-14-08	CORRECTED PART NUMBERS
D	-	-
E	-	-

DESIGN: JTM	DRAWN: JTM	AS BUILT: -	PROJECT NUMBER: SF-1004	SCALE: NONE	DATE: 3-14-08	REV: C
			SWORDFISH SPREADER CABLE SYSTEM			
			METRI-PACK 150 HYDRAULIC CABLE			
			SHT 1 OF 1			



# B.O.M.

MOLEX PIN#	SIGNAL	DEUTSCH	QTY	PART NUMBER	DESCRIPTION
2	DRIVE : BLACK (18 AWG)	1	1	39-01-2020	MOLEX RECEPTACLE 2 PIN
1	RETURN : WHITE (18AWG)	2	2	39-00-0039	MOLEX TERMINALS FEMALE 18-24 AWG
			18 FT	???	18 AWG, 2 COND. SVO CABLE or SIMILAR
			1	DT06-2S (LADD)	DEUTSCH PLUG
			2	0462-201-16141 (LADD)	FEMALE TERMINALS 16-18 AWG
			1	W2S (LADD)	DEUTSCH WEDGE LOCK

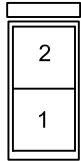

BACK VIEW  
(SIDE PINS ARE INSERTED FROM)

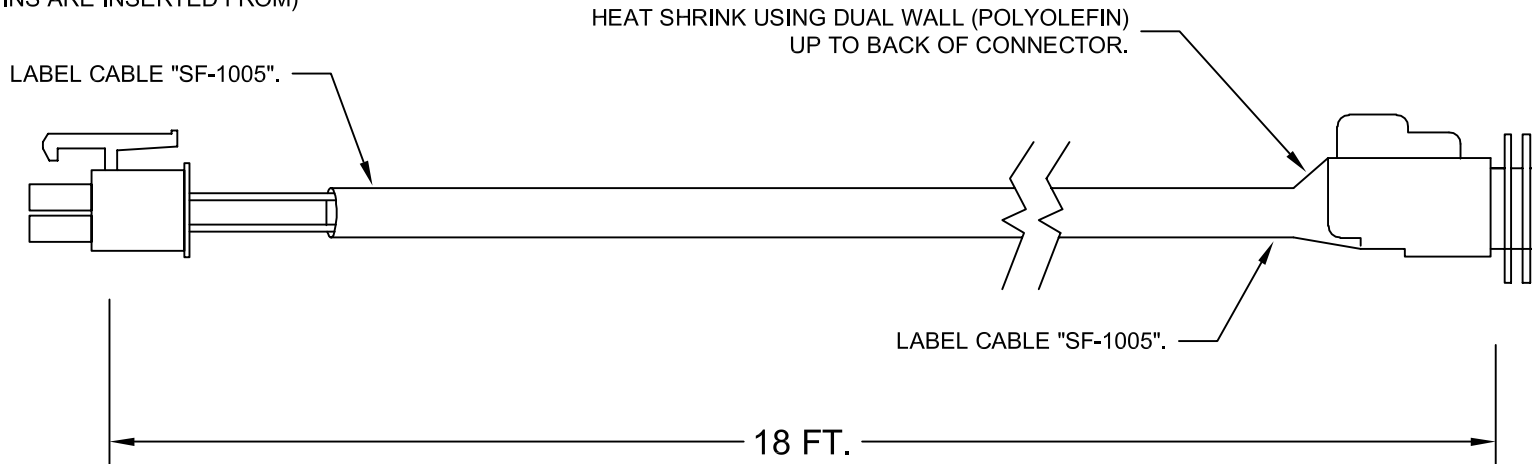

# SF-1005

THIS DRAWING IS THE PROPERTY OF CIRUS CONTROLS.  
THIS IS TO BE CONSIDERED CONFIDENTIAL AND  
PROPRIETARY NO REPRODUCTION IN WHOLE OR PART  
WITH OUT PERMISSION IS ALLOWED.

REV	DATE	DESCRIPTION
A	4-20-07	ADDED LABELS
B	9-5-07	REMOVED HEAT SHRINK OVER CONNECTOR
C	-	-
D	-	-
E	-	-

DESIGN:	JTM	DRAWN:	JTM	AS BUILT:	-
PROJECT NUMBER:	SF-1005	SCALE:	NONE	DATE:	4-20-07
				REV:	B
					SHT 1 OF 1

**CIRUS** Phone: (763) 493-9380  
**CONTROLS LLC** Fax: (763) 493-9340  
 9210 WYOMING AVE. N. SUITE 200  
 BROOKLYN PARK, MN 55445

SWORDFISH SPREADER CABLE SYSTEM

DEUTSCH HYDRAULIC CABLE

**B.O.M.**

**NOTES:**

- AVAILABLE CABLES FOR DIFFERENT VALVE TYPES  
(ORDER INDIVIDUALLY):  
PN# VAS 22-B653-.6M-WS 5.3T (DIN VALVE)
- PLUG FOR PORTS NOT USED:  
PN# VZ-3

ITEM	QTY	PART NUMBER	DESCRIPTION
1	1	4MB12 - 4P2	HYDRAULIC TRUNK AND BOX (TURCK)
2	1	39-01-2060 (Digi-Key #WM3702-ND)	MOLEX 6 PIN
3	6	39-00-0039 (Digi-Key #WM2501-ND)	MOLEX TERMINALS 18-24 AWG

HEAT SHRINK &  
LABEL CABLE WITH  
"TS-2018 HYD OUT"

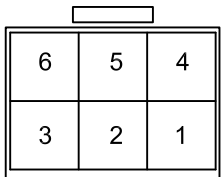
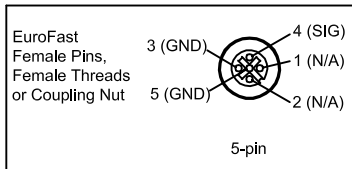
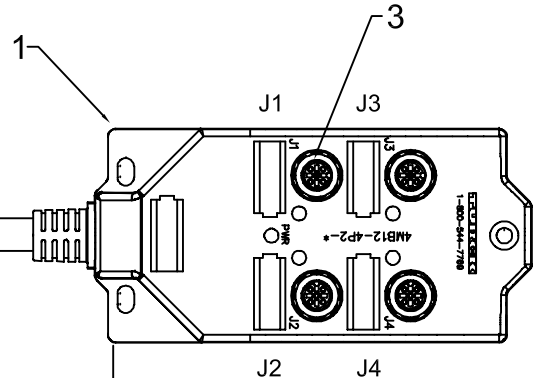
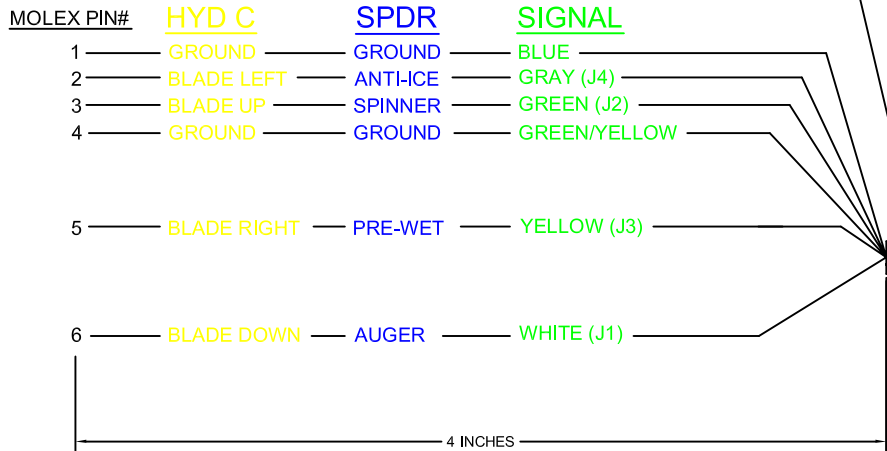

BACK VIEW  
(SIDE PINS ARE INSERTED FROM)

**CIRUS**  
CONTROLS LLC  
9200 WYOMING AVE. N. SUITE 320  
BROOKLYN PARK, MN 55445  
Phone: (763) 493-9380  
Fax: (763) 493-9340

THIS DRAWING IS THE PROPERTY OF CIRUS CONTROLS.  
THIS IS TO BE CONSIDERED CONFIDENTIAL AND  
PROPRIETARY NO REPRODUCTION IN WHOLE OR PART  
WITH OUT PERMISSION IS ALLOWED.

REV	DATE	DESCRIPTION
A	11-18-04	ADDED HYD C FUNCTIONS
B	3-18-05	ADDED HEAT SHRINK NOTE
C	08-01-07	Added some extra length for strain relief near spade
D	3-14-07	removed spades
E	-	-

DESIGN: JTM	DRAWN: JTM	AS BUILT: -	PROJECT NUMBER: TS-2018	SCALE: NONE	DATE: 3-14-08	REV: D
			SHT 1 OF 1			

SPREADER CABLE SYSTEM

HYDRAULIC CABLE

**WIRING DIAGRAM**

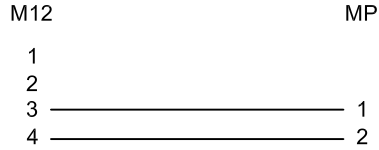

**B.O.M.**

ITEM	QTY	PART NUMBER	DESCRIPTION
1	1	WSC 4T - 0,62	M12 90 degree connector and cable
2	1	38201 (waytek)	FEMALE METRI-PACK 150 2 pin
3	2	31077 (waytek)	FEMALE TERMINALS 16-18 AWG
4	1	38202 (waytek)	TPA LOCK
4	2	39006 (waytek)	CABLE SEALS

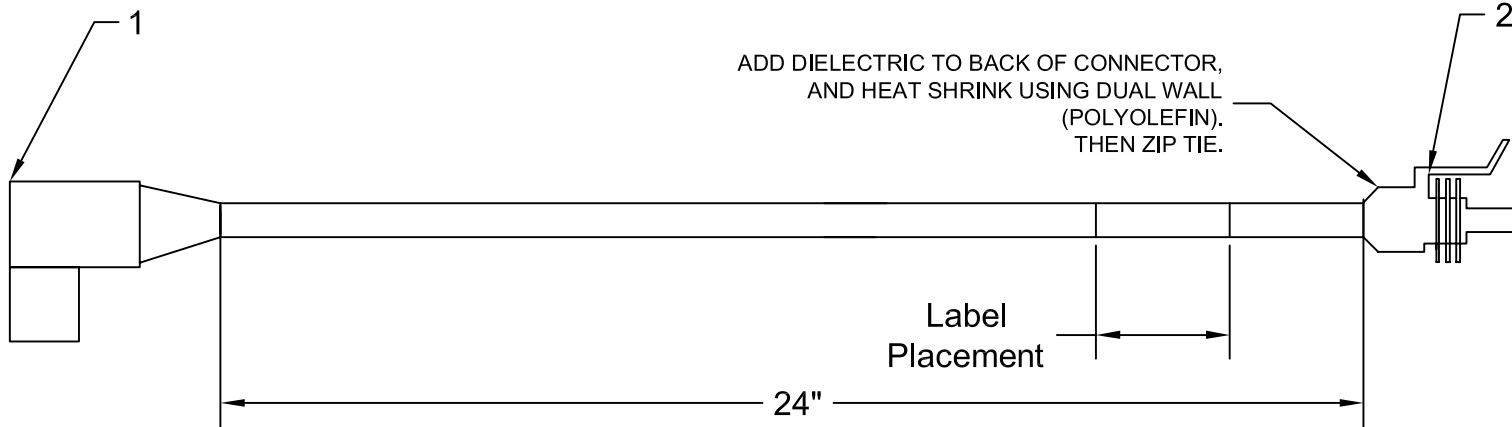

Notes:

- 18 AWG, 2 Conductor cable
- Label to be white w/ black printing and located on cable per drawing. (mylar w/ clear cover, all caps, 15pt font)
- M12 MATES TO SENSOR BOX 4MB12-4P2

**Cirus Controls**  
 9200 Wyoming Ave. N, Suite 320  
 Brooklyn Park, MN 55445  
 Tel: (763) 493-9380  
 Fax: (763) 493-9340

THIS DRAWING IS THE PROPERTY OF CIRUS CONTROLS  
 THIS IS TO BE CONSIDERED CONFIDENTIAL AND NO  
 REPRODUCTION IN WHOLE OR PART WITH OUT  
 PERMISSION IS ALLOWED.

REV	DATE	DESCRIPTION
A	-	-
B	-	-
C	-	-
D	-	-
E	-	-

SPREADER CABLE SYSTEM	
M12 TO METRI-PACK 150	
DESIGN: JTM	DRAWN: JTM
AS BUILT: -	PROJECT NUMBER: TS-2017
SCALE: NONE	DATE: 8-2-06
	SHT 1 OF 1

#TS-2017

**WIRING DIAGRAM**

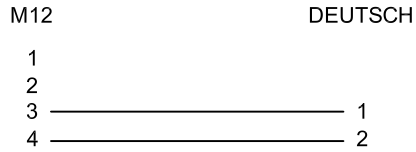

**B.O.M.**

ITEM	QTY	PART NUMBER	DESCRIPTION
1	1	WSC 4T - 0.62	M12 90 degree connector and cable
2	1	DT06-2S (LADD)	DEUTSCH PLUG
3	2	0462-201-16141 (LADD)	FEMALE TERMINALS 16-18 AWG
4	1	W2S (LADD)	DEUTSCH WEDGE LOCK

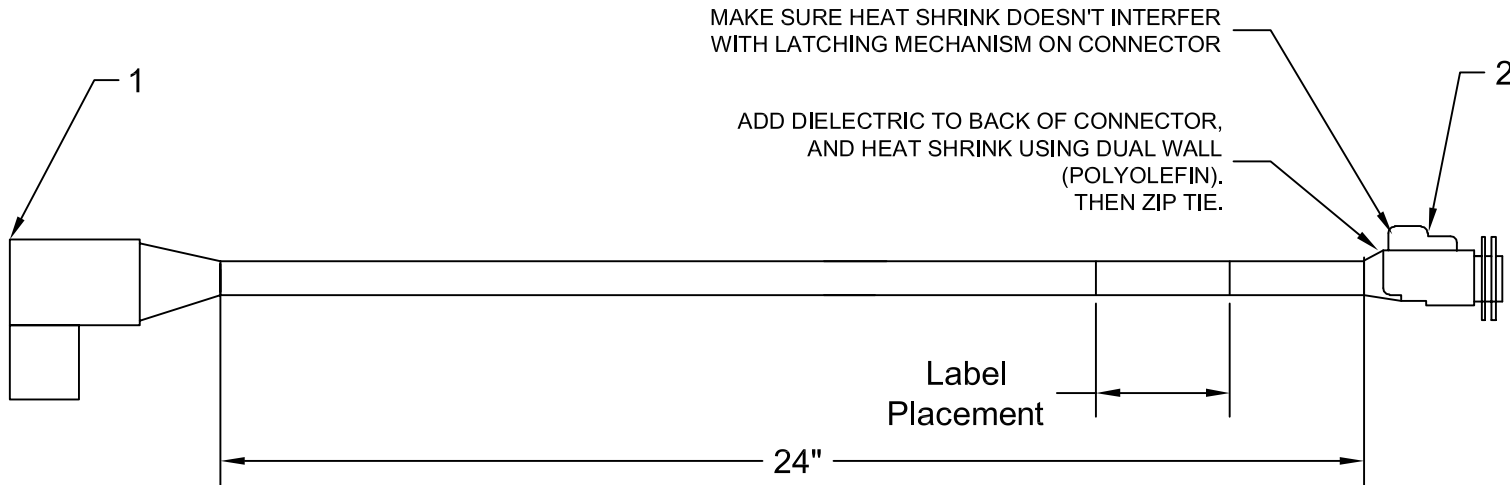

Notes:

- 18 AWG, 2 Conductor cable
- Label to be white w/ black printing and located on cable per drawing. (mylar w/ clear cover, all caps, 15pt font)
- M12 MATES TO SENSOR BOX 4MB12-4P2

**Cirus Controls**  
 9200 Wyoming Ave, N, Suite 320  
 Brooklyn Park, MN 55445  
 Tel: (763) 493-9380  
 Fax: (763) 493-9340



THIS DRAWING IS THE PROPERTY OF CIRUS CONTROLS  
 THIS IS TO BE CONSIDERED CONFIDENTIAL AND NO  
 REPRODUCTION IN WHOLE OR PART WITH OUT  
 PERMISSION IS ALLOWED.

REV	DATE	DESCRIPTION
A	-	-
B	2-21-07	ADDED HEAT SHRINK NOTE
C	-	-
D	-	-
E	-	-

DESIGN: JTM    DRAWN: JTM    AS BUILT: -

SPREADER CABLE SYSTEM			
M12 TO DEUTSCH DT06-2S			
PROJECT NUMBER:	SCALE:	DATE:	REV:
TS-2020	NONE	11-28-06	B
SHT 1 OF 1			

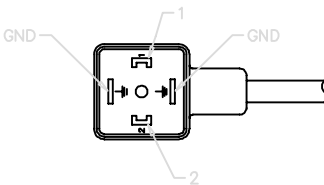
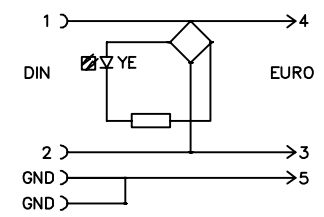
#TS-2020

DIN 43650 (FEMALE)	WIRING DIAGRAM	MALE END VIEW	SPECIFICATIONS	
		 <i>eurofast</i>	CONTACT CARRIER MATERIAL	NYLON OR PUR
			CONTACT MATERIAL/PLATING (VALVE)	SILVER-PLATED BRASS
			CONTACT MATERIAL/PLATING (EUROFAST)	GOLD-PLATED BRASS
			MOLDED HEAD MATERIAL	POLYURETHANE
			COUPLING NUT MATERIAL	NICKEL-PLATED BRASS
			RATED CURRENT	4.0 A
			RATED VOLTAGE	24-48 VAC/DC
			OUTER JACKET MATERIAL/COLOR	PUR/GREY
			NUMBER OF CONDUCTORS	3x18 AWG
			CONDUCTOR INSULATION	PVC
			TEMPERATURE RATING	-40°C to +105°C (-40°F to +221°F)
			PROTECTION CLASS	MEETS NEMA 1,3,4,6P AND IEC IP67

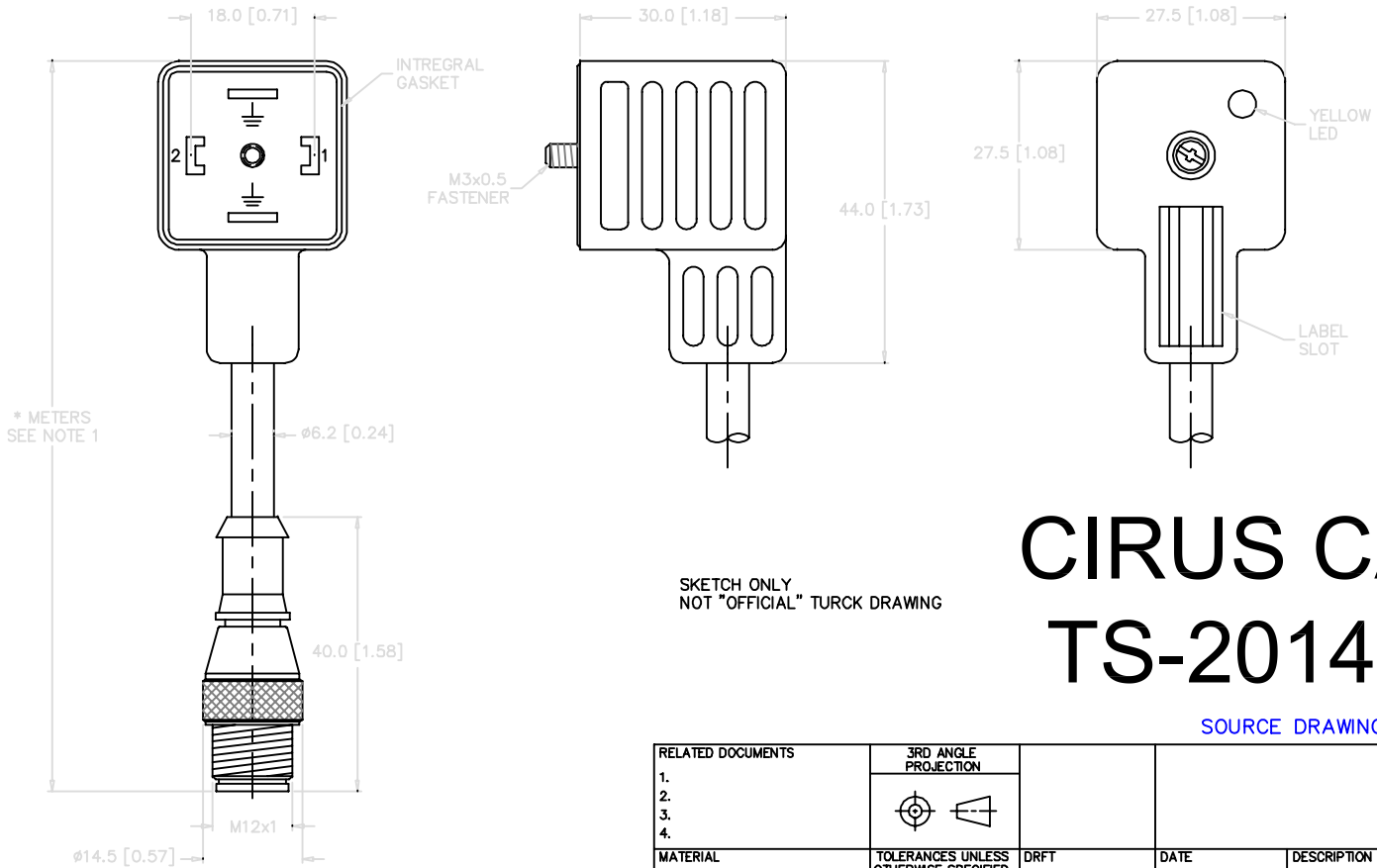

SKETCH ONLY  
NOT "OFFICIAL" TURCK DRAWING

# CIRUS CABLE # TS-2014

SOURCE DRAWING - FOR REFERENCE ONLY

NOTES:  
1. "\*" INDICATES CABLE LENGTH IN METERS. CONTACT TURCK TO ORDER SPECIFIC LENGTHS.

REV	DESCRIPTION	BY	DATE	ECO NO.
A	DRAWING RELEASE	JBJ	02/11/03	

RELATED DOCUMENTS		3RD ANGLE PROJECTION		DESCRIPTION	
1.				VAS 22-B839-.85M-WSC 5.3T	
2.					
3.					
4.					
MATERIAL		TOLERANCES UNLESS OTHERWISE SPECIFIED	DRFT	DATE	
FINISH			DSGN	SCALE	
			UNIT OF MEASUREMENT		IDENTIFICATION NO.
					TS-2014
					REV
			DO NOT SCALE THIS DRAWING		FILE:
					SHEET OF

# B.O.M.

## WIRING DIAGRAM

M12	ITT
1	
2	
3	1
4	2

ITEM	QTY	PART NUMBER	DESCRIPTION
1	1	WSC 4T - 0.62	M12 connector and cable
2	1	317-1398-000	SURESEAL BOOT
3	1	120-1804-000	SURESEAL RECEPTACLE
4	1	031-1267-001	SURESEAL TIN SOCKET
5	1	030-2196-001	SURESEAL TIN PIN

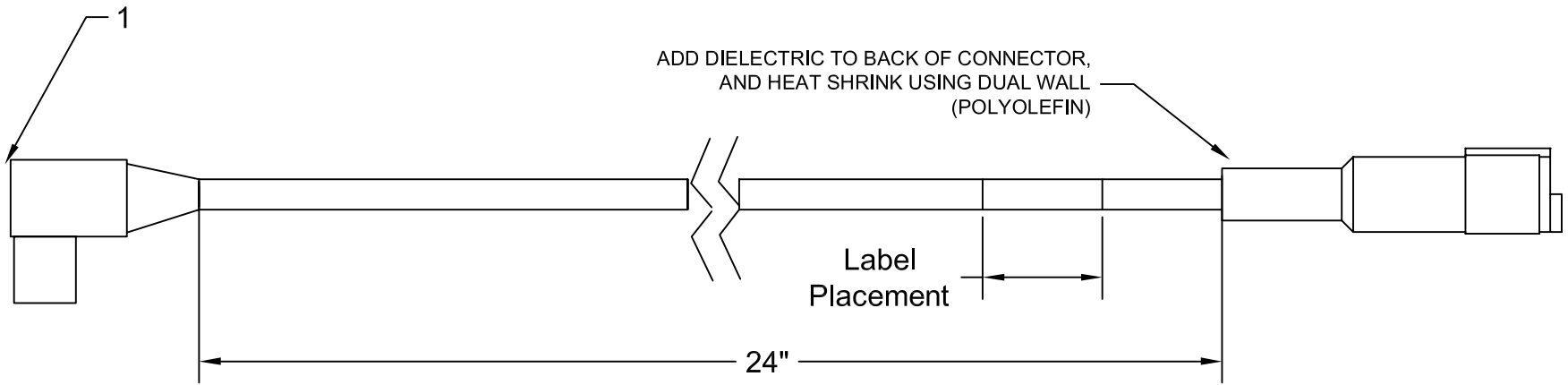

### Notes:

- 18 AWG, 2 Conductor cable
- Label to be white w/ black printing and located on cable per drawing. (mylar w/ clear cover, all caps, 15pt font)
- M12 MATES TO SENSOR BOX 4MB12-4P2

**Cirus Controls**  
 9200 Wyoming Ave, N, Suite 320  
 Brooklyn Park, MN 55445  
 Tel: (763) 493-9380  
 Fax: (763) 493-9340

THIS DRAWING IS THE PROPERTY OF CIRUS CONTROLS  
 THIS IS TO BE CONSIDERED CONFIDENTIAL AND NO  
 REPRODUCTION IN WHOLE OR PART WITH OUT  
 PERMISSION IS ALLOWED.

REV	DATE	DESCRIPTION			
A	3-16-05	ADDED HEAT SHRINK NOTE	SPREADER CABLE SYSTEM		
B	-	-			
C	-	-			
D	-	-			
E	-	-	M12 TO ITT CANNON PLUG		
E	-	-			
DESIGN:	JTM	DRAWN:	JTM	AS BUILT:	-
PROJECT NUMBER:		TS-2013	SCALE:	NONE	DATE: 3-16-05
					REV: A
					SHT 1 OF 1

# B.O.M.

WIRING DIAGRAM	
M12	AMP
1	
2	
3	1
4	2

ITEM	QTY	PART NUMBER	DESCRIPTION
1	1	WSC 4T - 0.62	M12 90 degree connector and cable
2	1	282080-1	AMP Superseal 1.5 RECEPTACLE
3	2	183025-1	FEMALE TERMINAL for Superseal 1.5
4	2	281934-2	18 AWG SEAL for Superseal 1.5

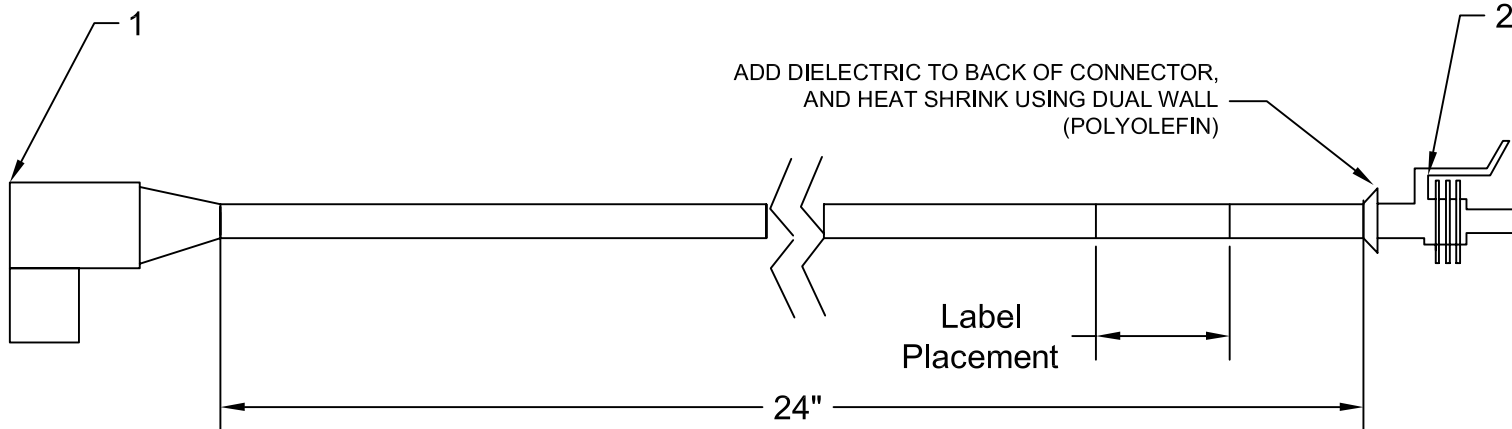

**Notes:**

- 18 AWG, 2 Conductor cable
- Label to be white w/ black printing and located on cable per drawing. (mylar w/ clear cover, all caps, 15pt font)
- M12 MATES TO SENSOR BOX 4MB12-4P2

**Cirus Controls**  
 9200 Wyoming Ave, N, Suite 320  
 Brooklyn Park, MN 55445  
 Tel: (763) 493-9380  
 Fax: (763) 493-9340

THIS DRAWING IS THE PROPERTY OF CIRUS CONTROLS  
 THIS IS TO BE CONSIDERED CONFIDENTIAL AND NO  
 REPRODUCTION IN WHOLE OR PART WITH OUT  
 PERMISSION IS ALLOWED.

REV	DATE	DESCRIPTION			
A	3-16-05	ADDED HEAT SHRINK NOTE	SPREADER CABLE SYSTEM		
B	-	-			
C	-	-			
D	-	-			
E	-	-	M12 TO AMP PLUG		
DESIGN: JTM		DRAWN: JTM		AS BUILT: -	PROJECT NUMBER: TS-2012
				SCALE: NONE	DATE: 3-16-05
				SHT 1 OF 1	
				REV: A	

**WIRING DIAGRAM**

M12	AMP
1	
2	
3	1
4	2

**B.O.M.**

ITEM	QTY	PART NUMBER	DESCRIPTION
1	1	WSC4.2T-0.6	M12 90 degree connector and cable
2	1	282189 - 1	AMP Junior Timer RECEPTACLE
3	2	929930 - 3	FEMALE TERMINAL for AMP Junior Timer
4	2	828905 - 1	18 AWG SEAL for AMP Junior Timer

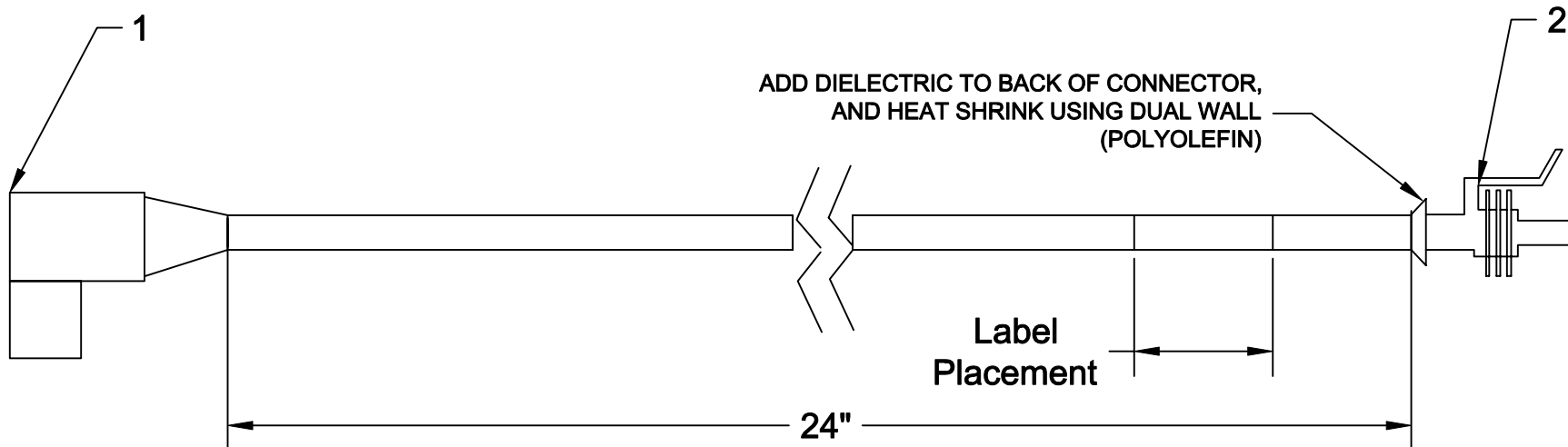

**Notes:**

- 18 AWG, 2 Conductor cable
- Label to be white w/ black printing and located on cable per drawing. (mylar w/ clear cover, all caps, 15pt font)
- M12 MATES TO SENSOR BOX 4MB12-4P2

**Cirus Controls** 9200 Wyoming Ave. N, Suite 320  
 Brooklyn Park, MN 55445  
 Tel: (763) 493-9380  
 Fax: (763) 493-9340

THIS DRAWING IS THE PROPERTY OF CIRUS CONTROLS  
 THIS IS TO BE CONSIDERED CONFIDENTIAL AND NO  
 REPRODUCTION IN WHOLE OR PART WITH OUT  
 PERMISSION IS ALLOWED.

REV	DATE	DESCRIPTION
A	3-16-05	ADDED HEAT SHRINK NOTE
B	-	-
C	-	-
D	-	-
E	-	-

<b>SPREADER CABLE SYSTEM</b>			
<b>M12 TO AMP JR Timer</b>			
DESIGN:	DRAWN:	AS BUILT:	PROJECT NUMBER:
JTM	JTM	-	TS-2011
SCALE:		DATE:	REV.
NONE		3-16-05	A
SHT 1 OF 1			



**WIRING DIAGRAM**

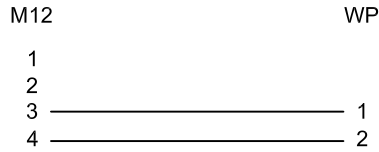

**B.O.M.**

ITEM	QTY	PART NUMBER	DESCRIPTION
1	1	WSC 4T - 0.62	M12 90 degree connector and cable
2	1	38043 (waytek)	weatherpack 2 pin (tower half)
3	2	30035 (waytek)	tower terminals 20- 18 awg
4	2	39000 (waytek)	weatherpack seals

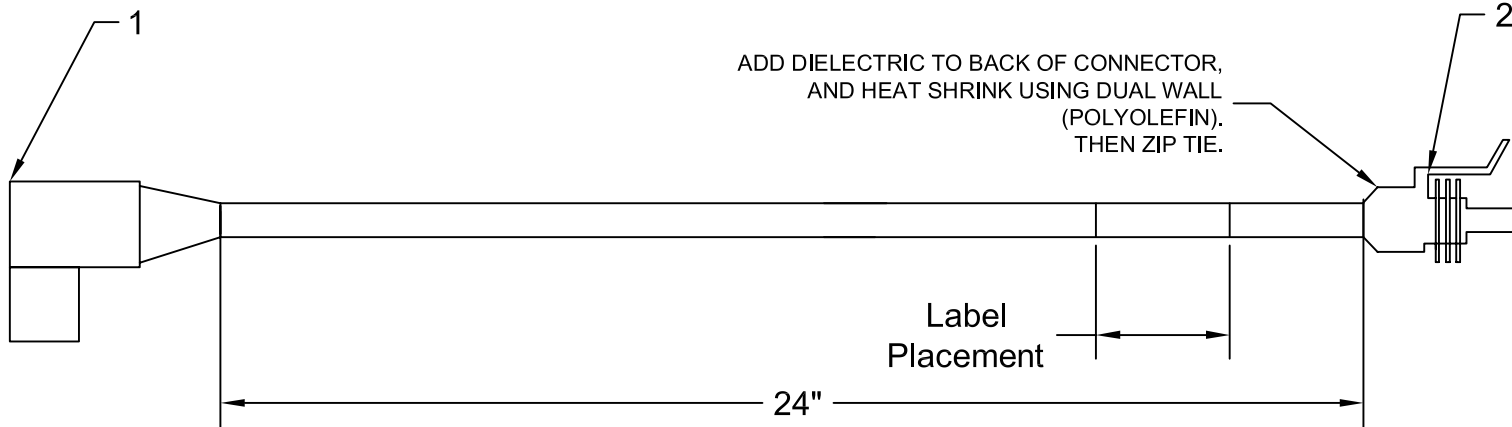

Notes:

- 18 AWG, 2 Conductor cable
- Label to be white w/ black printing and located on cable per drawing. (mylar w/ clear cover, all caps, 15pt font)
- M12 MATES TO SENSOR BOX 4MB12-4P2

**Cirus Controls**  
 9200 Wyoming Ave, N, Suite 320  
 Brooklyn Park, MN 55445  
 Tel: (763) 493-9380  
 Fax: (763) 493-9340

THIS DRAWING IS THE PROPERTY OF CIRUS CONTROLS  
 THIS IS TO BE CONSIDERED CONFIDENTIAL AND NO  
 REPRODUCTION IN WHOLE OR PART WITH OUT  
 PERMISSION IS ALLOWED.

REV	DATE	DESCRIPTION	PROJECT NUMBER:	SCALE:	DATE:	REV.
A	3-16-05	ADDED HEAT SHRINK AND DIELECTRIC NOTE	TS-2010	NONE	3-16-05	A
B	-	-				
C	-	-				
D	-	-				
E	-	-				

#TS-2010

SPREADER CABLE SYSTEM

M12 TO WEATHERPACK

SHT 1 OF 1