



Open-Circuit Mobile Pumps

HYDRAULICS

CONTROLS

REPORTING

Powerful engineering for open-circuit piston pumps

In short, these pumps pack power and performance into a small package. Offering a compact design and expansive functioning capabilities, Certified Power Solutions provides powerful hydraulics solutions with Eaton open-circuit mobile piston pumps that offer simple swashplate and single stroking piston design.

OPEN-CIRCUIT MOBILE PUMPS

- Open-circuit, axial piston design
- Pressure and flow control
- Load sensing with energy-saving standby mode
- 21 – 53 GPM flow capacities
- Up to 4060 psi pressure rating
- 49-80cc direct mountable on PTO - Series 420
- 49-80cc for driveline mount - Series 420
- 98cc available for driveline mount - Series 620
- Eaton-built low-oil shutdown (de-stroke) valve optional
- ISO 9001:2000 certified manufacturing



Series 420

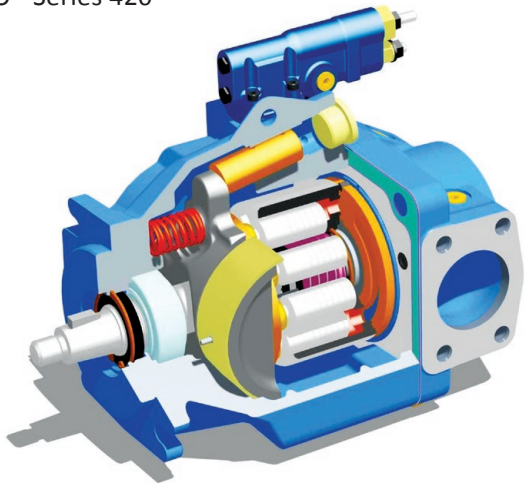

Cut away view of Series 620

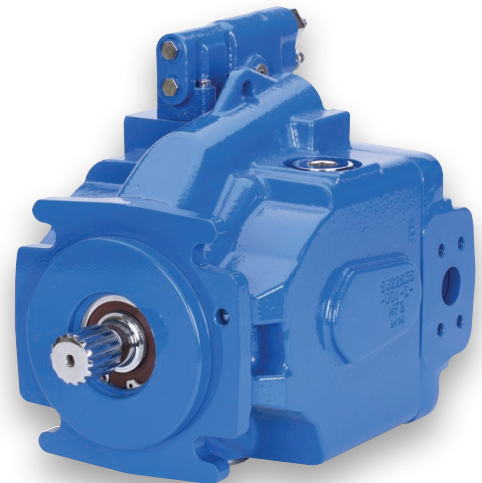

Series 620



certifiedpowersolutions.com



Minneapolis, MN
763-493-9380
cps-mn@certifiedpower.com

Chicago, IL
847-573-3800
cps-il@certifiedpower.com

Des Moines, IA
515-244-7411
cps-ia@certifiedpower.com

St. Louis, MO
314-344-3300
cps-mo@certifiedpower.com

Toledo, OH
419-873-7411
cps-oh@certifiedpower.com